

Kubos™ Paper Holder

FEATURES:

- Brass construction
- Corrosion resistant finishes
- Mounting hardware is included
- Coordinates with Kubos Collection

STOCK FINISHES:



PC BN

SPECIALTY FINISHES:



BBZ MB ORB PB PN

WARRANTY:

Visit www.speakman.com for full product warranty information

- Limited Lifetime Warranty (consumer)
- 1 Year Limited Warranty (commercial)

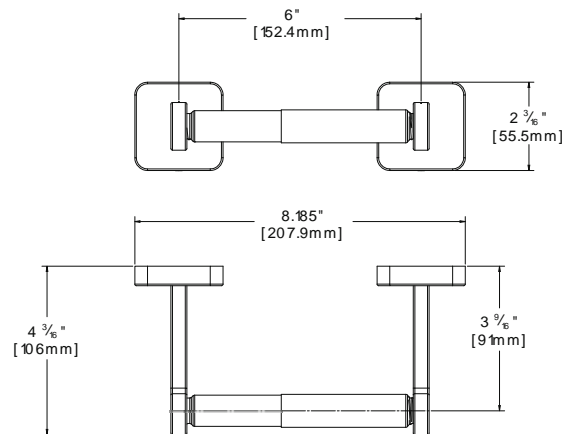

All dimensions are in inches (millimeters) unless otherwise specified and are subject to change without notice.

Architect/Engineer Approval Space:

SPEAKMAN
400 ANCHOR MILL ROAD
NEW CASTLE, DE 19720

P: 800-537-2107
F: 800-977-2747
W: WWW.SPEAKMAN.COM
R: 01-MARCH 2018