

INSTALLATION INSTRUCTIONS

American Standard

AquaWash® 2.0 SpaLet® Seat

Model 8019A60GPC

Thank you for selecting American Standard – the benchmark of fine quality for over 100 years. To ensure this product is installed properly, please read these instructions carefully before you begin. (Certain installations may require professional help.) Also be sure your installation conforms to local codes.

NOTE: Pictures may not exactly depict toilet seat and components.

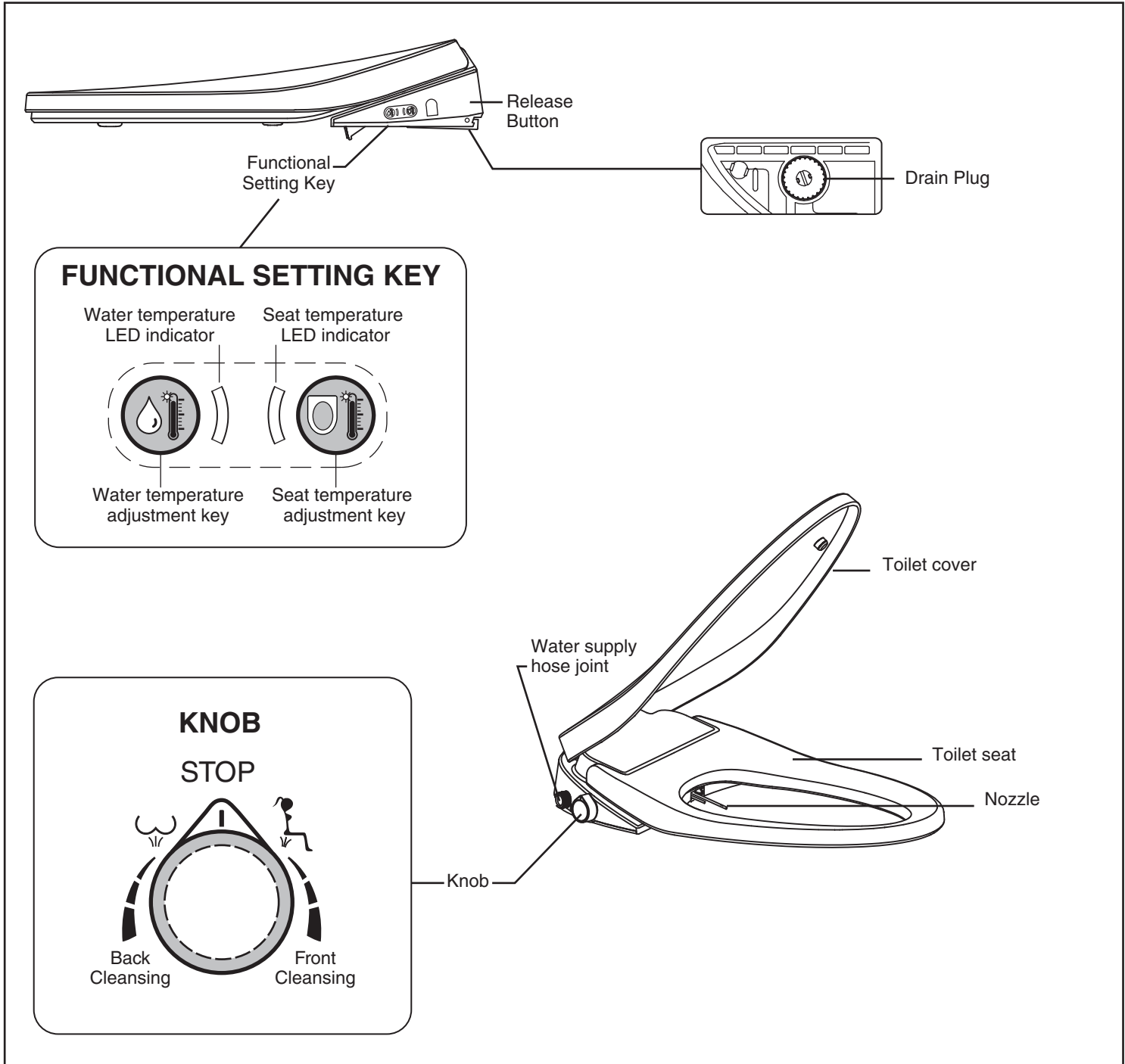

SAVE FOR FUTURE USE



760294-100

All product names listed herein are trademarks of AS America, Inc. unless otherwise noted.
© AS America, Inc. 2018

760294-100

1 SpaLet® Seat

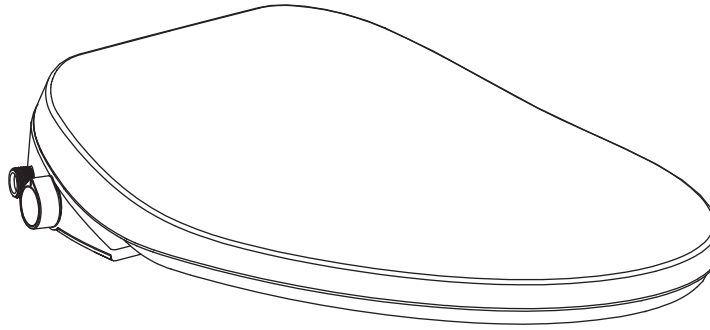

2 Fixing Components

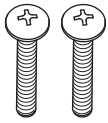

Bolt (2)

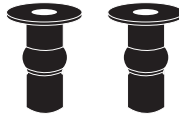

Insert (2)
(Apply to Top Mount)

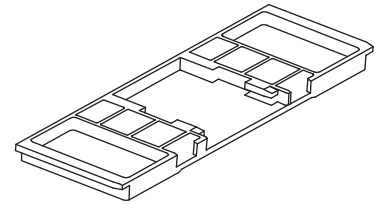

Base Plate (1)



Sliding Plate (2)



Nut (2)
(Apply to Bottom Mount)

3 T-SHAPED ADAPTER

GASKET

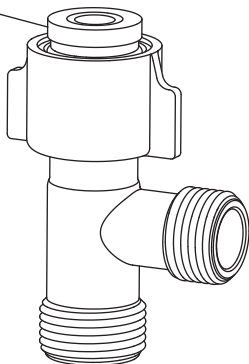

4 CONNECTION HOSE WITH FILTER

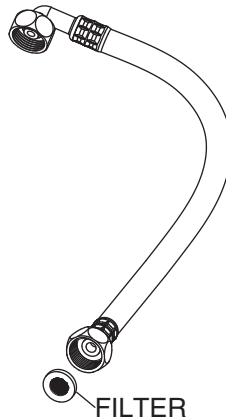

FILTER

5 USER'S MANUAL

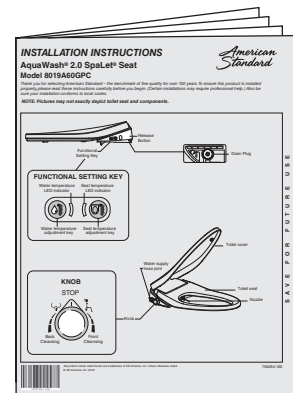

INSTALLATION

Please read the instructions carefully before installing and using.



WARNING

The product requires a flexible supply hose.

The water shutoff valve should be near the installed product for ease of installation.

Do not use in hot water line. Temperature above 104°F / 40°C will damage the product and void your warranty.

1 Remove existing toilet seat.



2A Press the inserts into the toilet bowl holes. Align the base plate to the slotted area of the template and then place the hardware onto the base plate as shown. Using a medium size Phillips screwdriver, start screwing down the bolts into the inserts until the base plate is fixed.

If the insert does not fit the bowl, proceed to Step 2B, otherwise, skip Step 2B and continue with Step 3.

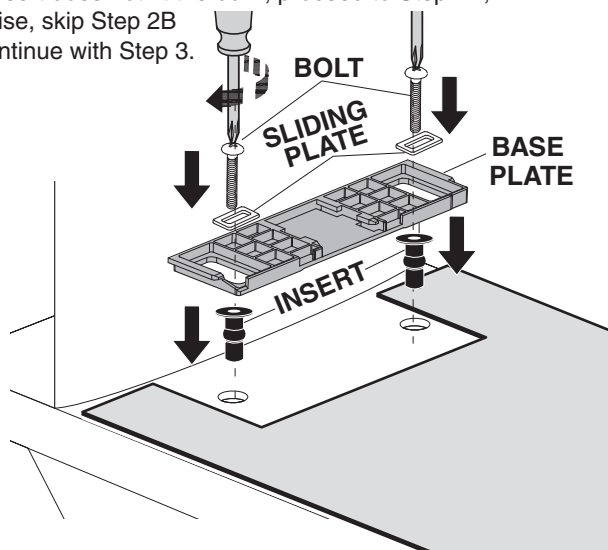

2B Place the base plate in the slotted area of the template and then place the hardware onto the base plate as shown. Screw in the nuts from the underside of the ceramic until the base plate is fixed.

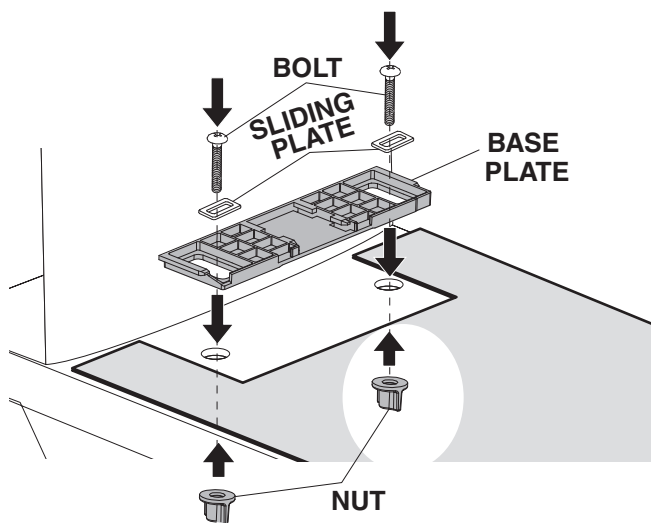

3 Slide the SpaLet® seat across the base plate until you hear a click. The SpaLet seat is now assembled to the bowl.

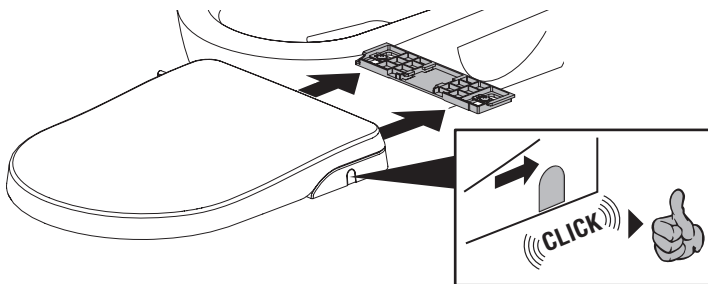

4 Turn off the water supply by turning off the water shutoff valve, then disconnect the supply hose.

If you are using a rigid supply line you will need to purchase a flexible supply hose to install the SpaLet seat.

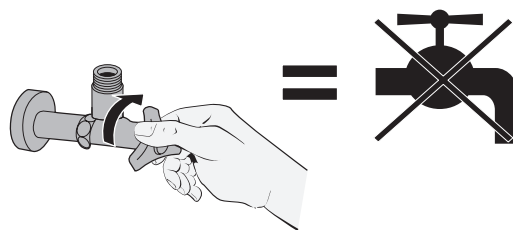

5 Install T-shaped adapter to the fill valve and supply hose as shown. Connect the included connection hose with filter on to the T-shaped adapter and the SpaLet® seat inlet.

⚠ WARNING
Make sure the filter and seal on the connection hose are installed along with the hose.

⚠ DO NOT OVERTIGHTEN THE THREADED CONNECTIONS.
The connections may be broken or the threads may be damaged if over torqued.

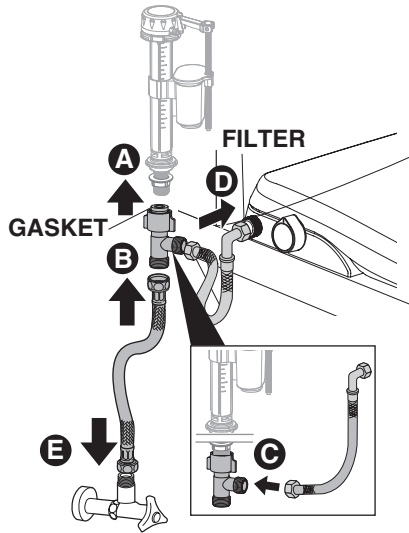

6 Make sure the control knob on the SpaLet seat is at the 90° off position. Turn the water shutoff valve back on.

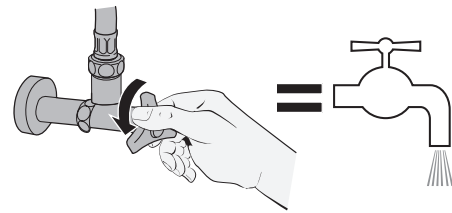
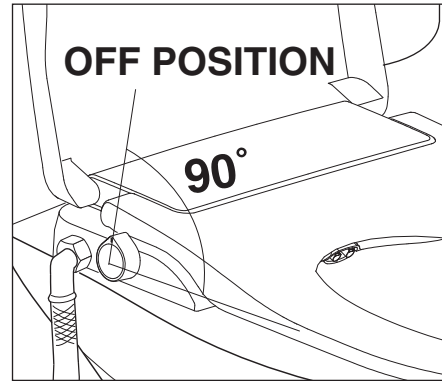

7 While sitting on the seat, rotate the control knob forward or backward for functional testing. Also, check the connections to make sure there are no leaks. If you find leaks retighten the connections.

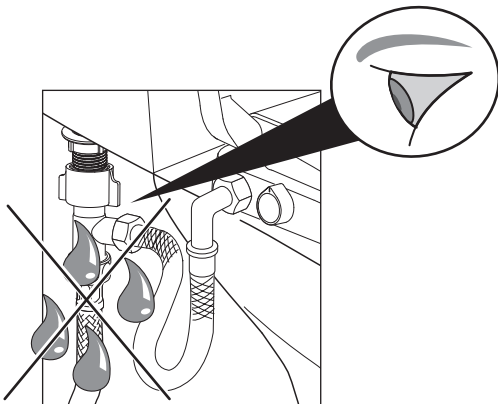
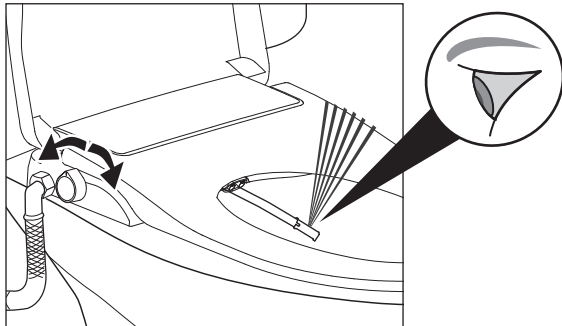

8 Plug power cord into designated AC power outlet.

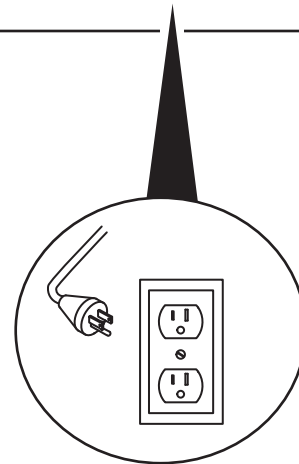
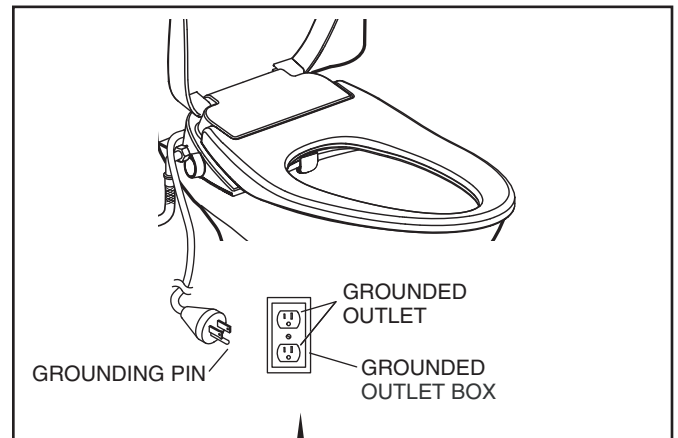

KNOB OPERATION

1. When the power cord is plugged into the AC wall socket, the SpaLet® is automatically powered ON and the KNOB light and Night light are constantly ON.
2. When the KNOB is turned to the Front or Back washing function, the KNOB's light will start to glow ON & OFF indicating one of the wands are extending.
3. When the KNOB is in the OFF or 90 degree position, the KNOB's light is ON.

FRONT CLEANSING FUNCTION

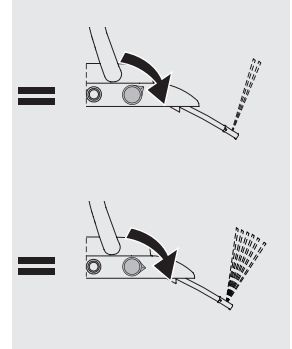
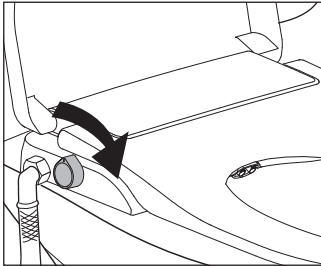

BACK CLEANSING FUNCTION

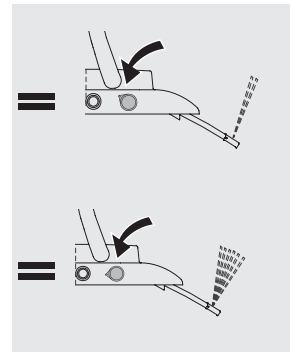
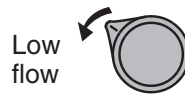
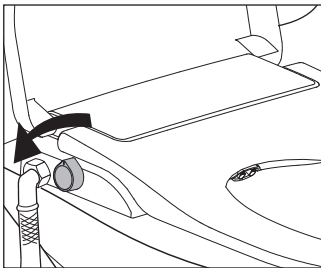

OFF AND SELF-CLEANING

Keep the knob at the 90° position when not in use. The wand cleans itself after each use. For additional cleaning of the wand, position the knob at 85° or 95° for a few seconds and then reposition back to 90°.

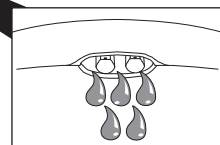
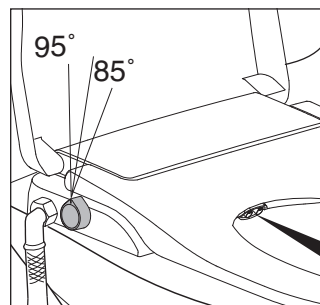
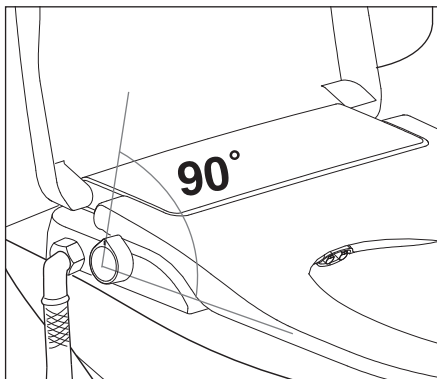

WATER AND SEAT TEMPERATURE SETTINGS

For Water Temperature description, follow below

Press the icon illustrating the “Water ” temperature button and the LED light for it will turn ON indicating Low Temp or about 95°F / 35°C. Press the button again and the LED light will appear brighter indicating a higher temperature, about 100°F / 38°C. Press a 3rd time and the LED will go OFF indicating heater is off.

For Seat Temperature description, follow below

Press the icon illustrating the “Seat ” temperature button and the LED light for it will turn ON indicating Low Temp or about 91°F / 33°C. Press the button again and the LED light will appear brighter indicating a higher temperature, about 98.6°F / 37°C. Press a 3rd time and the LED will go OFF indicating the heater is off.

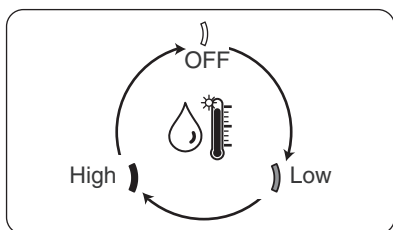
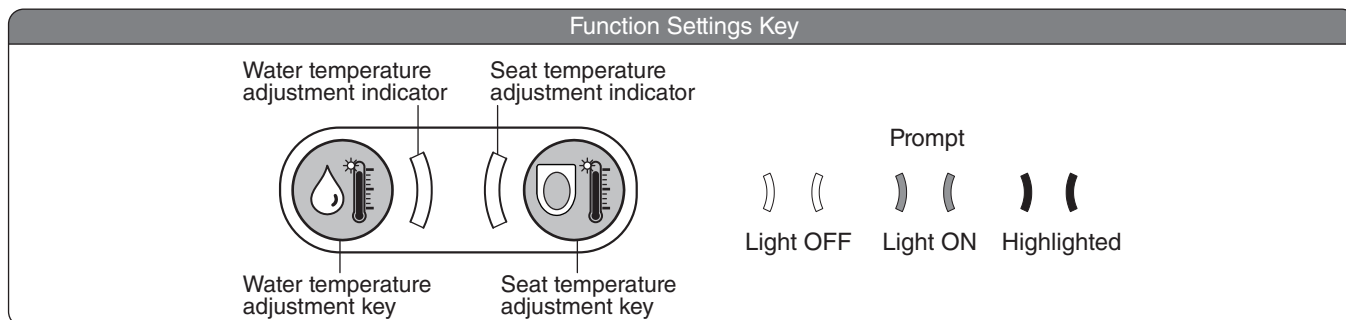

- Repeatedly press “” will switch over water temperature in the sequence indicated in the left figure.
- When you turn off the water temperature you will hear beeping for two seconds; when you switchover you will hear beeping for one second.
- Water temperature low setting: about 95°F / 35°C.
Water temperature high setting: about 100°F / 38°C.

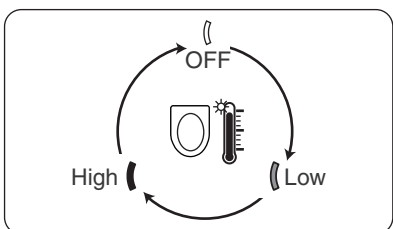

- Repeatedly press “” will switch over water temperature in the sequence indicated in the left figure.
- When you turn off the water temperature you will hear beeping for two seconds; When you switchover you will hear beeping for one second.
- Seat temperature low setting: about 91.4°F / 33°C.
Seat temperature high setting: about 98.6°F / 37°C.

PROTECTION FEATURES:

1. When seated for 5 minutes or longer, the SpaLet® will go into a Low temperature mode.
2. If the KNOB is not set to OFF (90 degrees up position) when a person moves off the seat, an alarm function will turn ON indicating one of the wands are still extended.

CLEANING AND MAINTENANCE

1 DO NOT USE AGGRESSIVE CHEMICALS: for example: hydrogen chloride, paint thinner, benzene, abrasive cloth or paper, polishing agent, fragrance, insecticide, etc.



2 You will need to clean the wands when they get build up of residue and calcium. You can pull the wands out with your finger and then with a soft bristle toothbrush, brush the nozzle head.

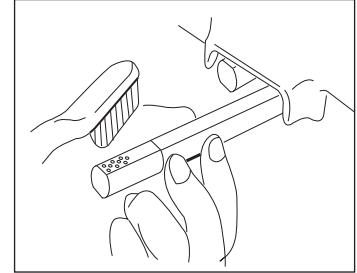

3 If you start to notice that the flow of water is low when using the SpaLet® seat it may be time for the filter to be cleaned out. Especially with new home construction or newly renovated plumbing there are a lot of sediments in the water. You will need to remove the connection hose and clean out the filter as needed.

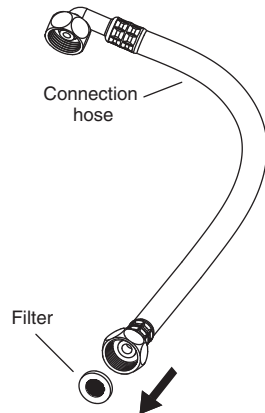

4 You can remove the SpaLet seat by pressing the release button on the right side of the SpaLet seat and sliding the seat forward as shown. This enables you to be able to clean more thoroughly around the toilet. Make sure to disconnect the connection hose before you do this.

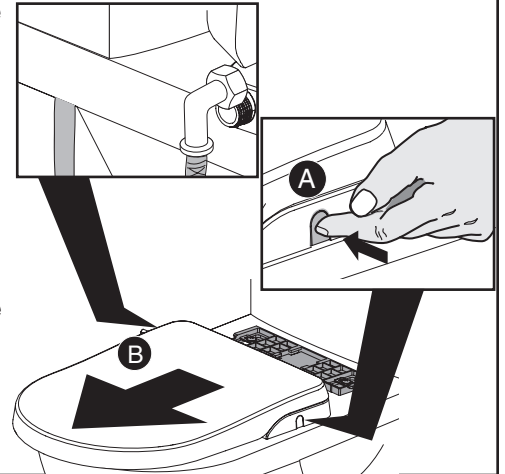

5 The nozzles can be removed if needed for cleaning. First turn off the water supply to the SpaLet seat. As per figure A, pull out the tube and remove the old nozzle by pulling out straight, as shown. As per figure B, insert the new nozzle into the tube along the corresponding slot.

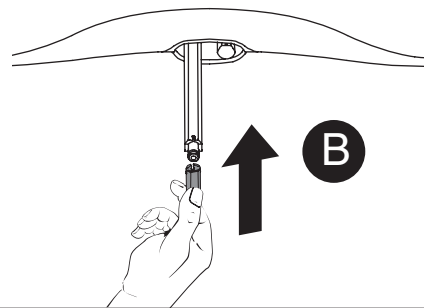
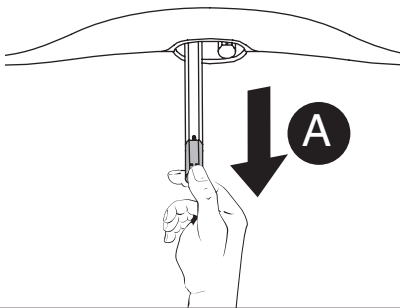

6 The incoming water pressure is regulated by a regulator insert. This can be removed and replaced. First turn off the water supply and disconnect the connection hose. Rotate the lever to the on position, pull out the regulator from the inlet tube with needle-nose pliers. Press the new regulator into the inlet tube. Then rotate the lever back to non-working position.

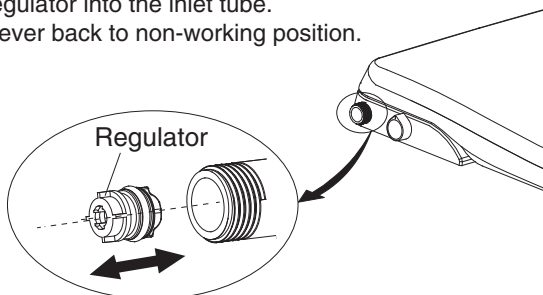

7 If anything shall leak, retighten the connection and use teflon tape if needed. If water leaks from the two ends of the water hose, retighten the nuts to avoid water leaking

! WARNING
DO NOT OVERTIGHTEN AS IT WILL DAMAGE THE CONNECTION. HAND TIGHTENING IS RECOMMENDED.

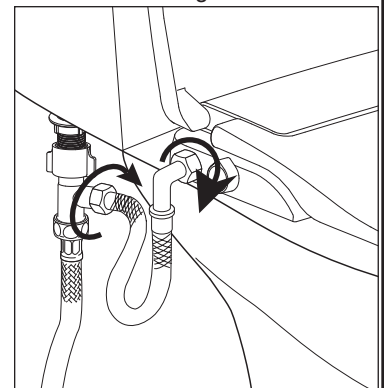

TROUBLESHOOTING GUIDE

PROBLEM	POSSIBLE CAUSE	CORRECTIVE ACTION
Water is too low during WASH/BIDET	1. Low water pressure of the unit	During WASH/BIDET, turn the knob to a higher setting
	2. Low water pressure of water supply	When water supply pressure is lower than 0.07 MPa (10 psi)
No water comes out during WASH/BIDET	1. Water shut-off valve is turned off	Turn on the water shut-off valve
	2. Filter of T-shaped connector is stuck	Clean the filter of T-shaped connector
	3. Filter of water inlet hose is stuck	Clean the filter of water inlet hose
	4. Nozzle head is stuck	Take off and clean the nozzle head
	5. External water pressure is low	Increase external water pressure
Water dropping from bowl when using the unit	External water pressure is too high	The maximum water pressure of the unit is 0.8 MPa (115 psi). If water supply pressure is higher than that, please contact local department for water pressure question.
No LED lights ON	No power	Check AC power cord and/or AC fuse breaker/fuse box
Seat Temperature too high/low	Not adjusted correctly	Adjust to desirable temperature
Water flows out when seated	Self-cleaning function is enabled	This is normal and will automatically stop in 5 seconds
Main AC breaker/fuse continuously trips	Power usage by seat may be beyond circuit provided	Pull power cord from socket, call electrician
Buzzer continuously beeps when leaving seat	KNOB switch not set to OFF at 90 degree position	Set KNOB to OFF at 90 degree position

AS AMERICA, INC. THREE YEAR LIMITED WARRANTY

If inspection of this AS America, Inc. ("American Standard") plumbing product, within one year after its initial purchase, confirms that it is defective in materials or workmanship, American Standard will repair or, at its option, exchange the product for a similar model.

This limited warranty applies only to the original purchaser and installation of these products. In the event of a limited warranty claim, proof of purchase will be required—save sales receipt.

This limited warranty does not apply to commercial installations. The warranty for commercial installations is two years on the SpaLe[®].

This limited warranty does not apply to local building code compliance. Since local building codes vary considerably, the purchaser of this product should check with a local building or plumbing contractor to insure local code compliance before installation.

This limited warranty is void if the product has been moved from its initial place of installation; if it has been subjected to faulty maintenance, abuse, misuse, accident or other damages; if it was not installed in accordance with American Standard's instructions; or if it has been modified in a manner inconsistent with the product as shipped by American Standard.

American Standard's option to repair or exchange the product under this limited warranty does not cover any labor or other costs of removal or installation. IN NO EVENT WILL AMERICAN STANDARD BE LIABLE FOR THE COST OF REPAIR OR REPLACEMENT OF ANY INSTALLATION MATERIALS, INCLUDING BUT NOT LIMITED TO, TILES, MARBLE, ETC. American Standard will not be responsible for any other incidental or consequential damages attributable to a product defect or to the repair or exchange of a defective product, all of which are expressly excluded from this limited warranty. This limited warranty does not cover any liability for consequential or incidental damages, all of which are hereby expressly disclaimed, or the extension beyond the duration of this limited warranty of any implied limited warranties, including those of merchantability or fitness for an intended purpose. (Some states or provinces do not allow the exclusion or limitation of implied limited warranties, so this exclusion may not apply to you.)

This limited warranty gives you specific legal rights. You may have other statutory rights that vary from state to state or from province to province, in which case this limited warranty does not affect such statutory rights.

In the United States:
 American Standard Brands
 1 Centennial Ave.
 Piscataway, New Jersey 08854
 Attention: Director of Customer Care

In Canada:
 LIXIL Canada, Inc
 5900 Avebury Rd.
 Mississauga, Ontario
 Canada L5R 3M3

In Mexico:
 American Standard B&K Mexico
 S. de R.L. de C.V.
 Via Morelos #330
 Col. Santa Clara
 Ecatepec 55540 Edo. Mexico

For residents of the United States, warranty information may also be obtained by calling the following toll free number: (800) 442-1902
www.americanstandard.com

Toll Free: (800) 387-0369
www.americanstandard.ca

Toll Free: 01-800-839-1200
www.americanstandard.com.mx

THIS WARRANTY IS NOT TRANSFERABLE FROM ORIGINAL CONSUMER PURCHASER.