









Thank you for purchasing the **MODWAY BAR TABLE!**

Before you start, here are some helpful advice:

1. We suggest you spend a short time reading through this leaflet and then follow the simple step by step instructions.
2. Owing to the size and weight of the bar table, we recommend that it is assembled by two adults, on a carpeted or padded area, in the room that it is intended for. Approximate assembly time: 30 minutes.
3. Please do not use any tools other than those provided or recommended in these instructions.
4. Please do not throw away any of the packaging or instructions until you have checked all the components and hardware and the furniture is fully assembled.
5. Assemble all components loosely until advised to tighten. Depending on use, it may be necessary to tighten the components from time to time, so please save the tools that have been provided.
6. Please keep all pieces out of reach of children.

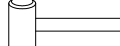

### Hardware:

A		Double-End Bolt	x 4
B		Long Bolt 1/4"x20mm	x 8
C		Flat Washer 1/4"	x 16
D		Nut 1/4"	x 4
E		Allen Wrench 1/4"	x 1
F		Wrench 1/4"	x 1
G		Plastic Cover	x 4
H		Spring Washer 1/4"	x 8
		Hammer (Not provided)	

### Component:

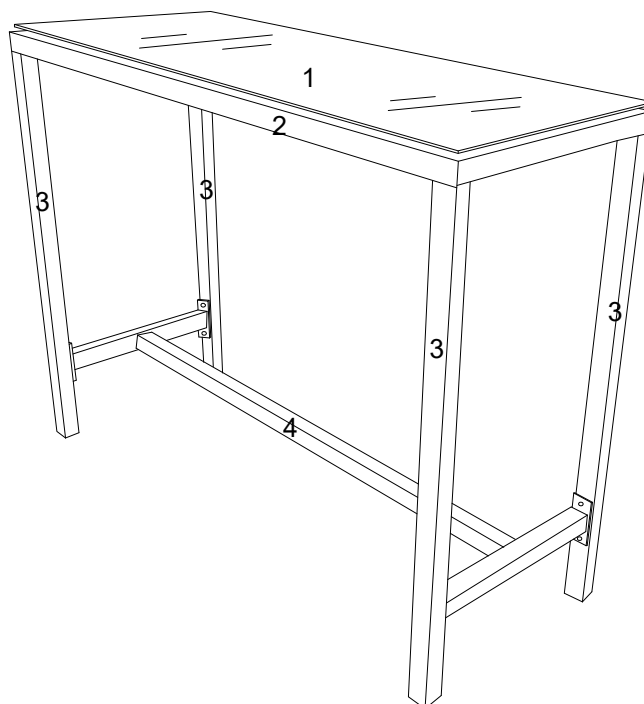

1	Table Glass	x1	2	Table Top	x1	3	Table Leg	x4	4	Stretcher	x1
---	-------------	----	---	-----------	----	---	-----------	----	---	-----------	----

## STEP 1:

Please put **Table Top (2)** upside down on a carpeted or padded area.

Fully secure 4 pieces of **Double-End Bolt (A)** with 4 pieces of **Spring Washer (H)**, 4 pieces of **Flat Washer (C)** into the bottom of **Table Top (2)** as shown.

Secure the assembled **Nuts (D)** towards **Table Top (2)** by hand as shown.

Insert **Wrench (F)** without handle into the assembled **Double-End Bolts (A)** and use **Wrench (F)** fully secure **Nuts** which pre-assembled on **Double-End Bolts (A)** by inserting half of handle into **Wrench (F)** as shown.

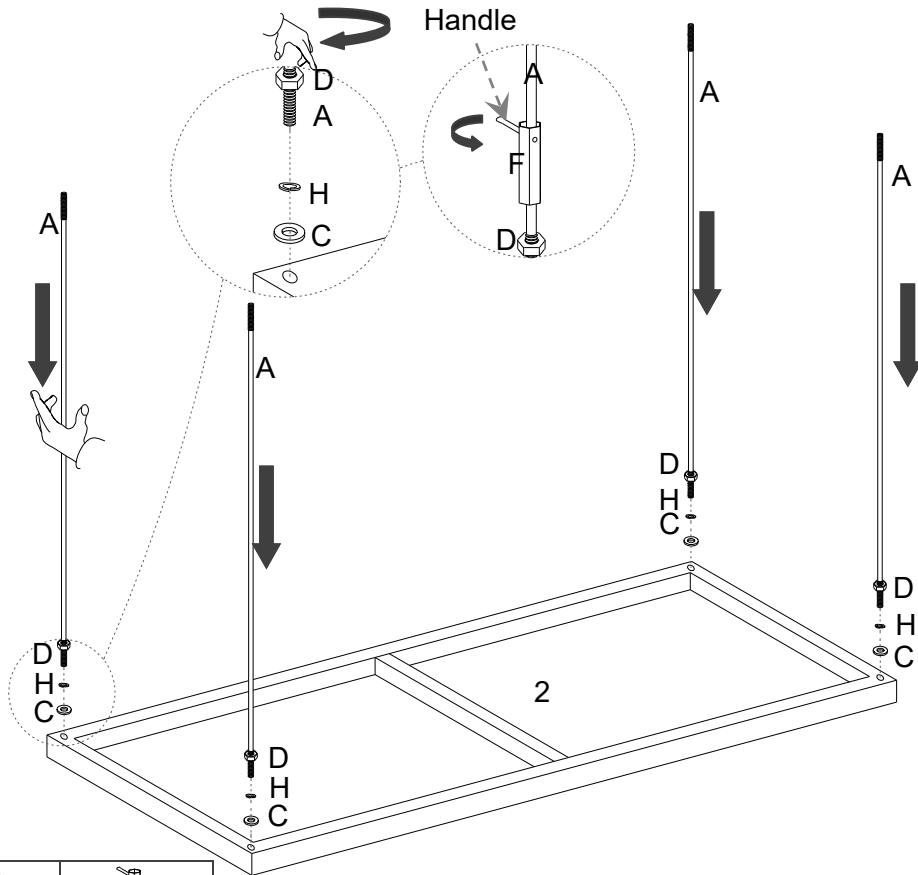

Hx4	Cx4	FX1

Hardware & Tool required

## STEP 2:

Put 4 pieces of **Table Leg (3)** to **Table Top (2)** through the assembled **Double-End Bolt (A)** as shown.

Note:

This side with middle of pre-drilled holes face toward to the another leg.

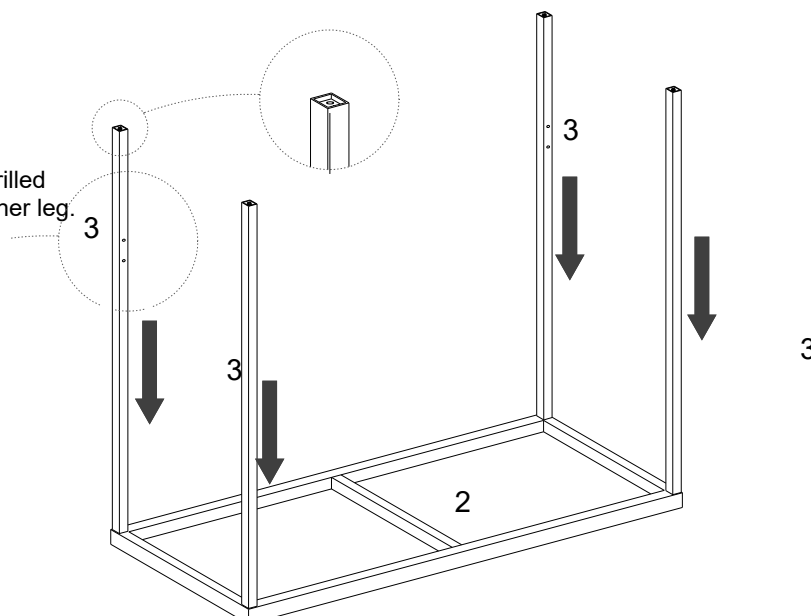

### STEP 3:

Place **Stretcher (4)** to the assembled **Table Top (2)** and **Table Legs (3)** as shown.

Insert 8 pieces of **Bolt (B)** with 8 pieces of **Flat Washer (C)** into the holes on **Table Leg (3)** through the holes on **Stretcher (4)**.

Use **Allen Wrench (E)** to tighten **Bolts (B)** clockwise until secure.

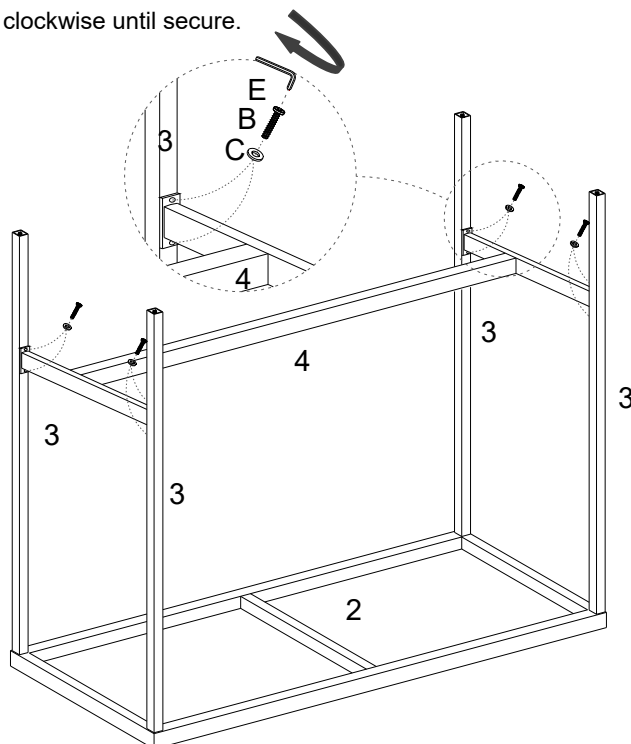

Bx8	Cx8	Ex1

Hardware & Tool required

### STEP 4:

Secure 4 pieces of **Nut (D)**, 4 piece of **Spring Washer (H)**, and 4 pieces of **Flat Washer (C)** to the other end of assembled **Double-End Bolt (A)** as shown.

Use **Wrench (F)** to tighten **Nuts (D)** clockwise until secure.

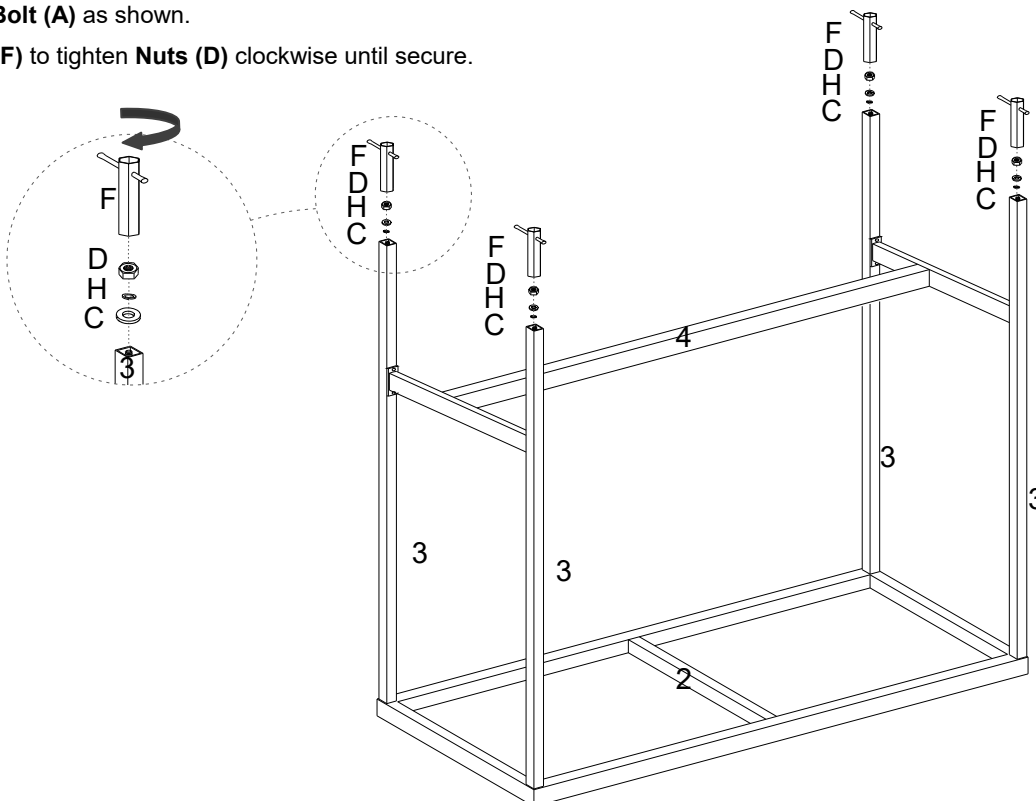

Dx4	Hx4	Cx4	Fx1

Hardware & Tool required

## STEP 5:

Insert 4 pieces of **Plastic Cover (G)** into the assembled **Table Leg (3)** by using **Hammer (Not provided)** as shown.

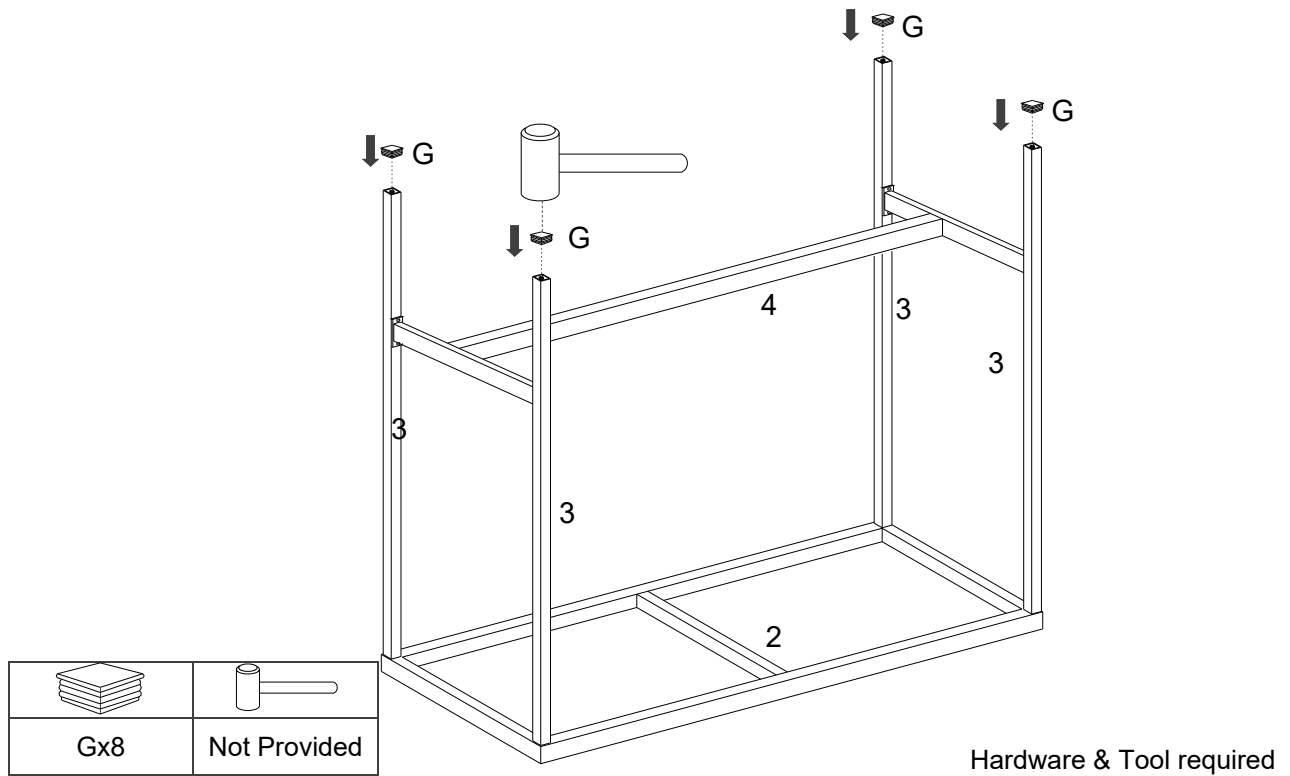

## STEP 6:

Carefully turn over the assembled bar table.

Put **Table Glass (1)** to the **Table Top (2)** as shown.

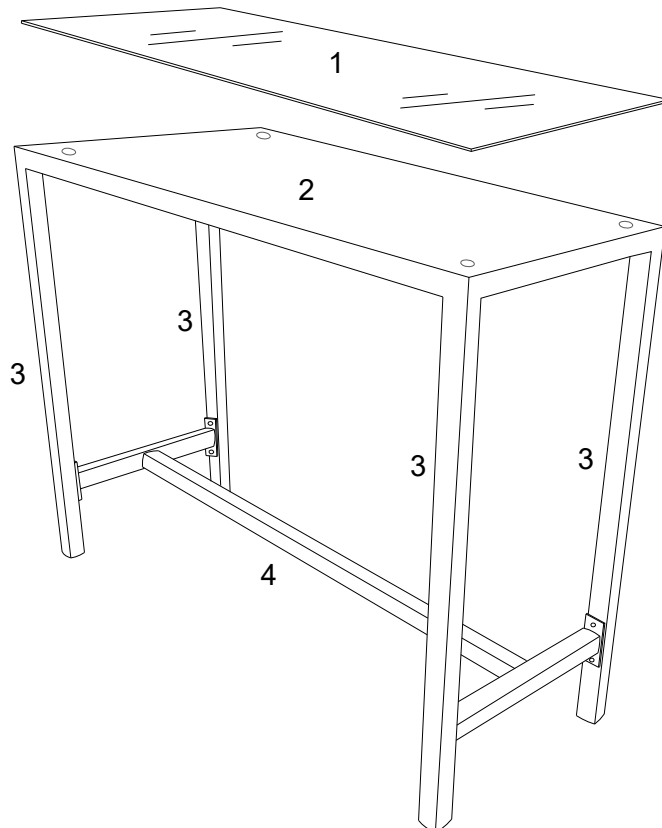

Assembly is complete. Your bar table is ready to be used now!