

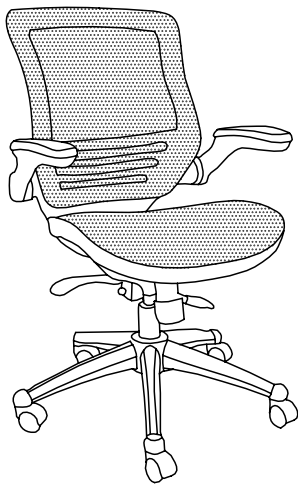





Thank you for purchasing the **MODWAY OFFICE CHAIR**!

Before you start, here is some helpful advice:

1. We suggest you spend a short time reading through this leaflet and then follow the simple step by step instructions.
2. Owing to the size and weight of the office chair, we recommend that it is assembled by two adults, on a carpeted or padded area, in the room that it is intended for. Approximate assembly time: 15 minutes.
3. Please do not use any tools other than those provided or recommended in these instructions.
4. Please do not throw away any of the packaging or instructions until you have checked all the components and hardware and the furniture is fully assembled.
5. Assemble all components loosely until advised to tighten. Depending on use, it may be necessary to tighten the components from time to time, so please save the tools that have been provided.
6. Please keep all pieces out of reach of small children.

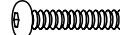

Hardware:

1		Short Bolt M8x25mm	x4
2		Small Bolt M6x25mm	x4
3		Long Bolt M8x30mm	x4
4		Flat Washer	x4
5		Allen Wrench	x1
6		Plastic Cover	x2
7		Plastic Cover	x2

Component:

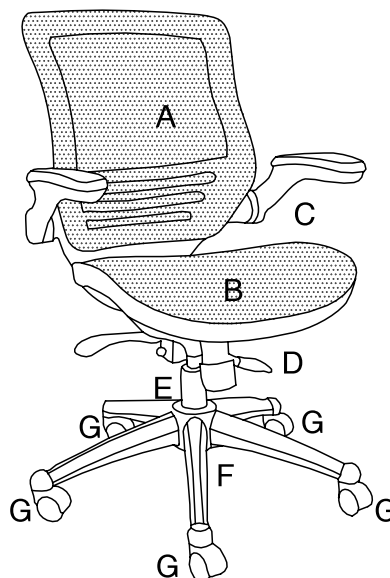

A	Chair Back	x1	B	Chair Seat	x1	C	Connect piece with Arm	x1
D	Control Mechanism	x1	E	Cylinder Column	x1	F	Chair Base	x1
G	Castor	x5						

STEP 1:

Please put the **Chair Base (F)** upside down on a carpeted or padded surface.
 Insert 1pc of **Castor (G)** into the **Chair Base (F)** as shown by hand.
 Repeat the same steps for the other 4pcs of **Castor (G)**.

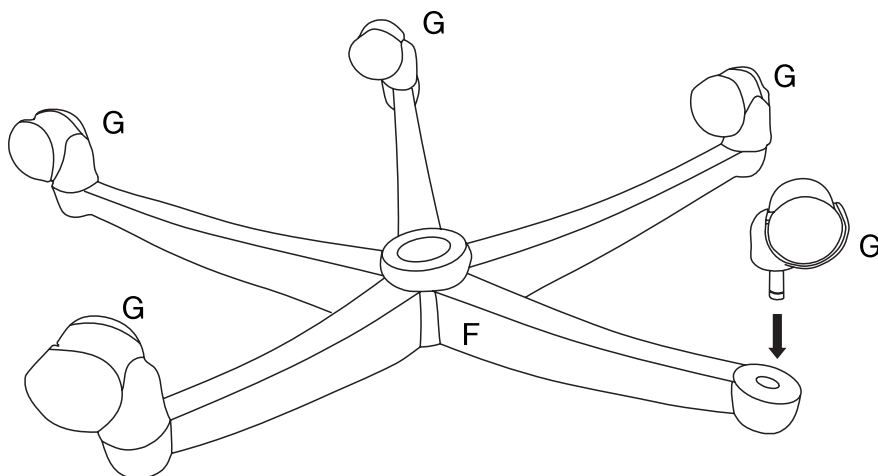

STEP 2:

Place a sealed carton on the floor with a carpeted or padded surface on the top side of carton.
 Please put a heavy object into the carton for balance prior to assembling the office chair.
 Please put the **Chair Back (A)** upside down on the carton.
 Attach the **Connect Piece with Arm (C)** into the bottom of **Chair Back (A)** by using **Bolts (2)** as shown.
 Use **Allen Wrench (5)** to tighten the **Bolts (2)** clockwise until secure.
 Insert the **Plastic Covers (6&7)** into the corresponding holes on the back of **Chair Back (A)** as shown.

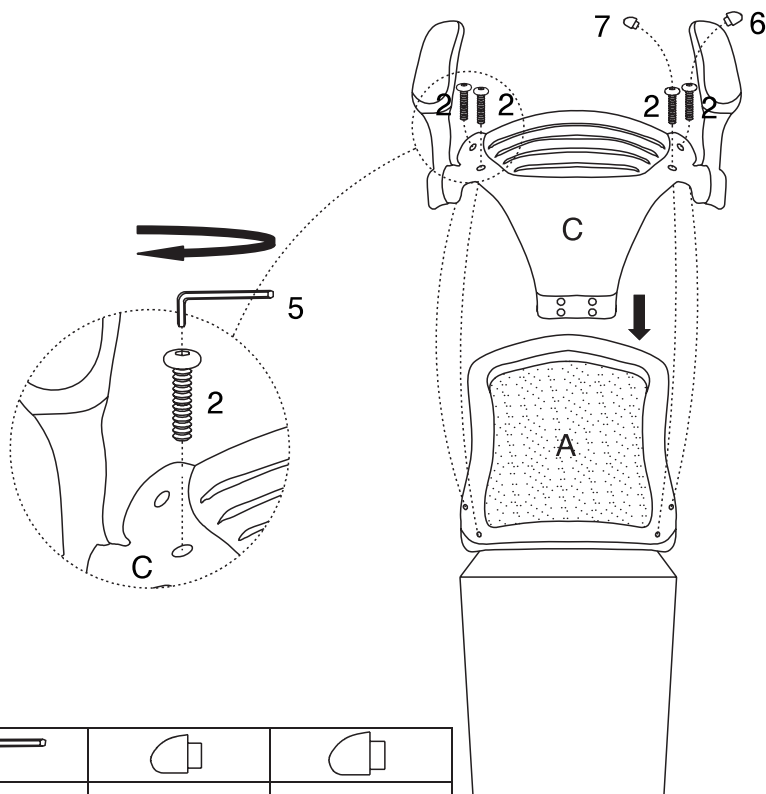

2x4pcs	5x1pc	6x2pcs	7x2pcs

Hardware & Tool required

STEP 3:

Please put the **Control Mechanism (D)** upside down on the carton.

Attach the assembled **Connect Piece with Arm (C)** into the **Control Mechanism (D)** by using **Long Bolts (3)** and **Flat Washers (4)** as shown.

Use **Allen Wrench (5)** to tighten the **Bolts (3)** clockwise until secure.

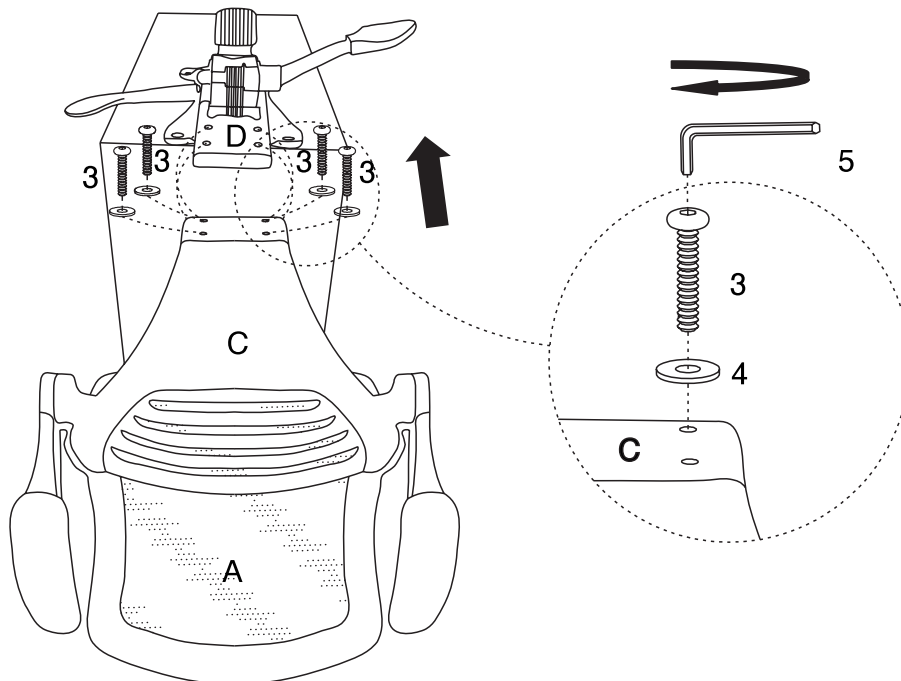

3x4pcs	4x4pcs	5x1pc

Hardware & Tool required

STEP 4:

Please put the **Chair Seat (B)** upside down on the carton.

Attach the assembled **Control Mechanism (E)** into the bottom of **Chair Seat (B)** by using **Bolts (1)** as shown.

Use **Allen Wrench (5)** to tighten the **Bolts (1)** clockwise until secure.

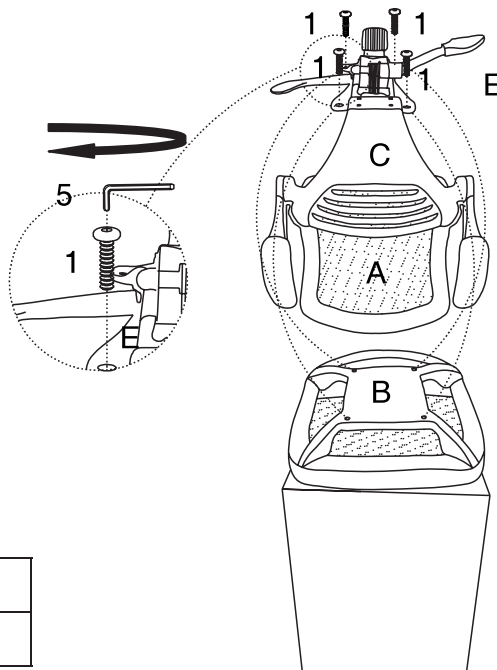

1x4pcs	5x1pc

Hardware & Tool required

STEP 5:

Insert the **Cylinder Column (E)** into the Bottom of **Control Mechanism (D)** as shown.

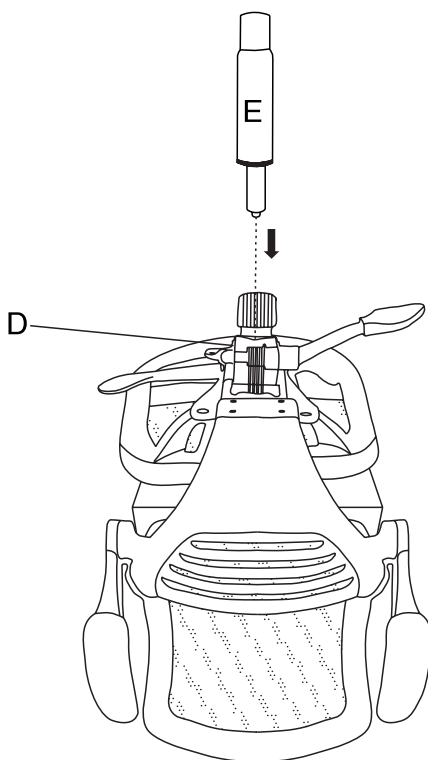

STEP 6:

Insert the assembled **Chair Base (F)** into the **Cylinder Column (E)** as shown.

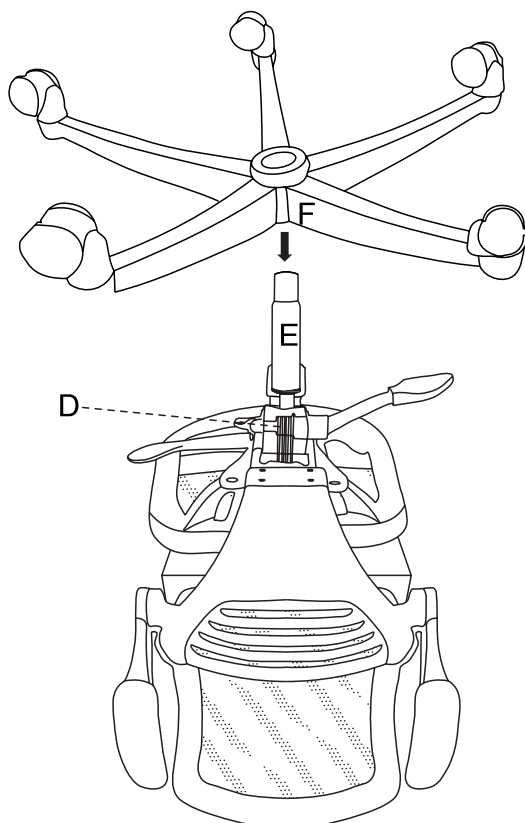

STEP 7:

Carefully turn over the office chair.

Put the **Arm** to the right position for using.



Assembly is completed. The office chair is ready to enjoy now!