

## Chelsea™ Pressure Balance Diverter Valve Trim

### FEATURES:

- Metal lever handles
- Plastic trim plate
- Includes mounting plate and hardware

### VALVE OPTIONS:

- CPV-P-DV

### STOCK FINISH:



PC BN

### STANDARDS:

- ASME A 112.18.1/CSA B 125.1 certified
- ADA compliant

### WARRANTY:

Visit [www.speakman.com](http://www.speakman.com) for full product warranty information

- Limited Lifetime Warranty (consumer)
- 5 Year Limited Warranty (commercial)

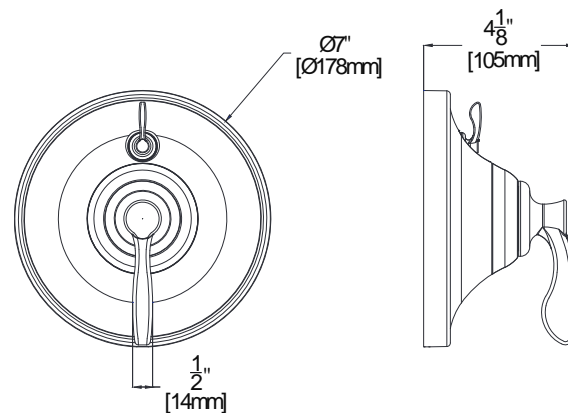

All dimensions are in inches (millimeters) unless otherwise specified and are subject to change without notice.

Architect/Engineer Approval Space:

SPEAKMAN  
400 ANCHOR MILL ROAD  
NEW CASTLE, DE 19720

P: 800-537-2107  
F: 800-977-2747  
W: WWW.SPEAKMAN.COM  
R: 01-APRIL 2018