

# **Kräus<sup>®</sup>**

INSTALLATION MANUAL

## **All-In-One Kitchen Set**

**KCA-1200**

## **Congratulations on the purchase of your new Kraus plumbing fixture!**

Please keep the box and packaging materials until your product is completely installed. If you have any questions, require technical assistance or have any problems with your product:

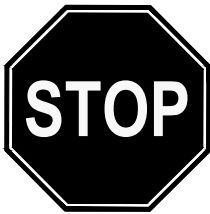

**DO NOT RETURN TO STORE**

**Please contact our Customer Service Team  
1-800-775-0703 / [customerservice@kraususa.com](mailto:customerservice@kraususa.com)**

Have the model number available and retain a copy of your receipt with purchase date for reference.

If for any reason this product does not meet your expectations, please be sure to repack this product in the original box and packaging material to avoid damage during transit.

## Prior to Installation:

- Make sure that you have all necessary parts by checking the parts list. If any part is missing or damaged, please contact Kraus Customer Service at 800-775-0703 for a replacement
- Inspect the sink prior to installation to make sure that it has not been damaged or during shipping
- Use the cut-out template provided by Kraus
- Observe all plumbing and building codes according to your state requirements
- Turn off the cold and hot water at the angle stops and turn on the old faucet to release and built up pressure
- Flush angle stops to release any debris prior to installation
- Pre-drilled hole size requirement: 1 3/8" (min) - 1 1/2" (max)
- Max countertop thickness: 1 1/2"

**For technical assistance or replacement parts, please contact Kraus Customer Service and one of our representatives will be happy to help:**

Toll-Free: 800-775-0703 or [customerservice@kraususa.com](mailto:customerservice@kraususa.com)

**NOTE: Please reference your batch number when calling, it can be found on the cold waterline.**

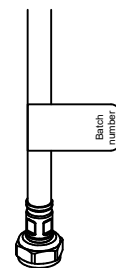

The step-by-step guidelines in the installation instructions are a general reference for installing a Kraus Sink. Should there be any discrepancies, Kraus cannot be held liable. It is recommended to install all Kraus products by hiring a licensed professional.

## Tools you will need:

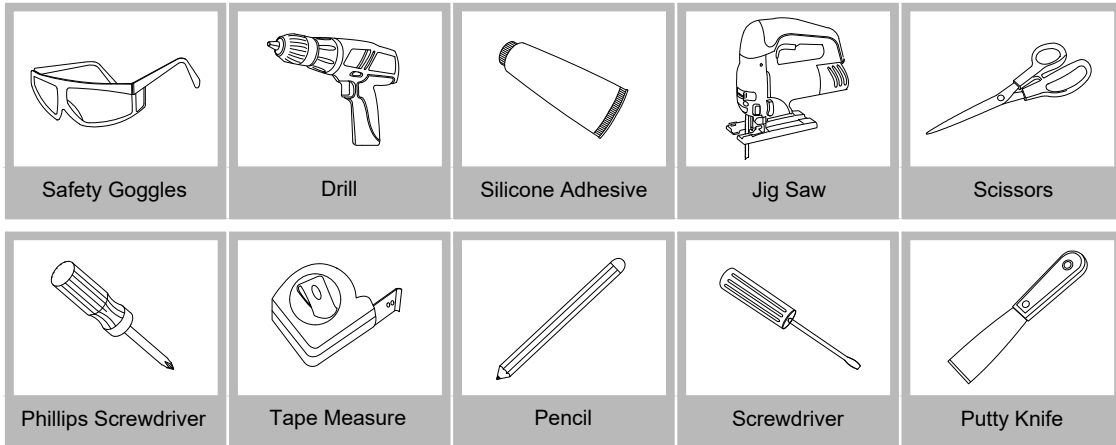

**NOTE:** Specialized tools may be necessary to install Kraus Stainless Steel Undermount sinks with countertop materials other than wood, marble or granite.

**Make sure to check off that you have all of the following items**

- Kitchen Sink - KBU32
- Kitchen Faucet - KPF-1610SS
- Cut-Out Template
- Undermounting Hardware
- Bottom Grid - KBG-32 (2)
- Drains - ST-1 (2)

## Sink Dimensions:

---

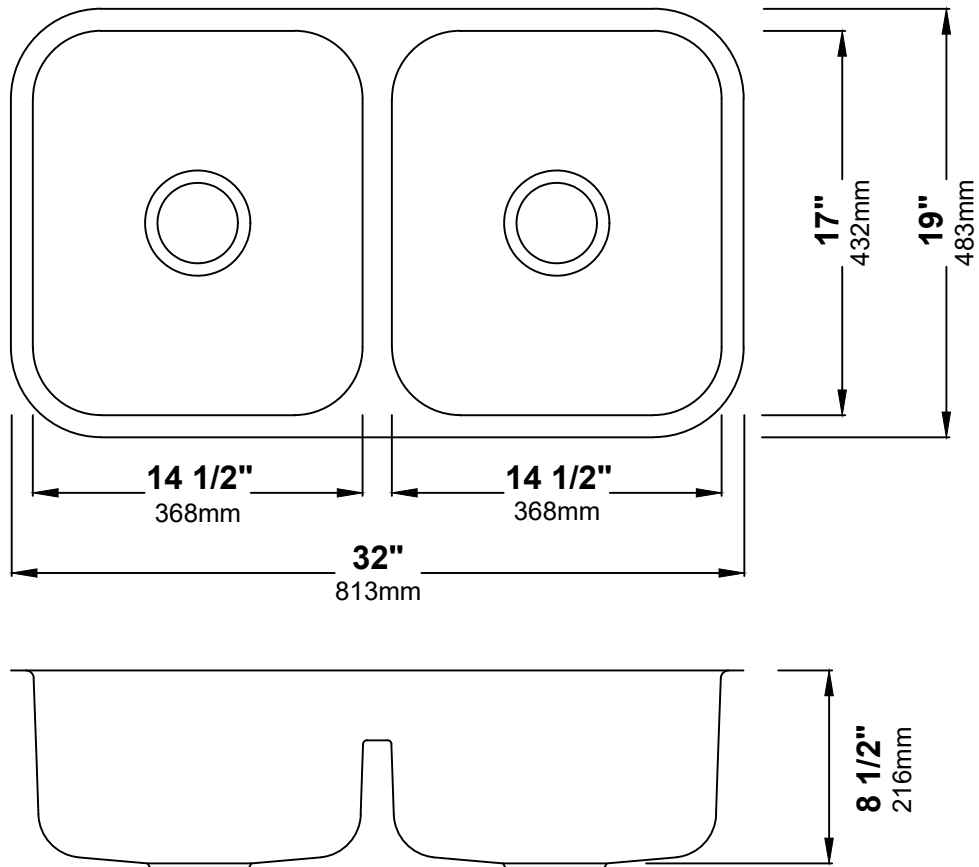

---

Model #: KBU32  
Sink Dimensions: 32" x 19" x 8 1/2"  
Min Cabinet Size: 36"  
Matching Grid: KBG-32 (2)  
Drain Model #: ST-1 (2)

# 1. Determine Reveal Type

---

Use scissors to cut along the line of the paper template for your desired reveal type (Negative, Positive or Flushed Reveal).

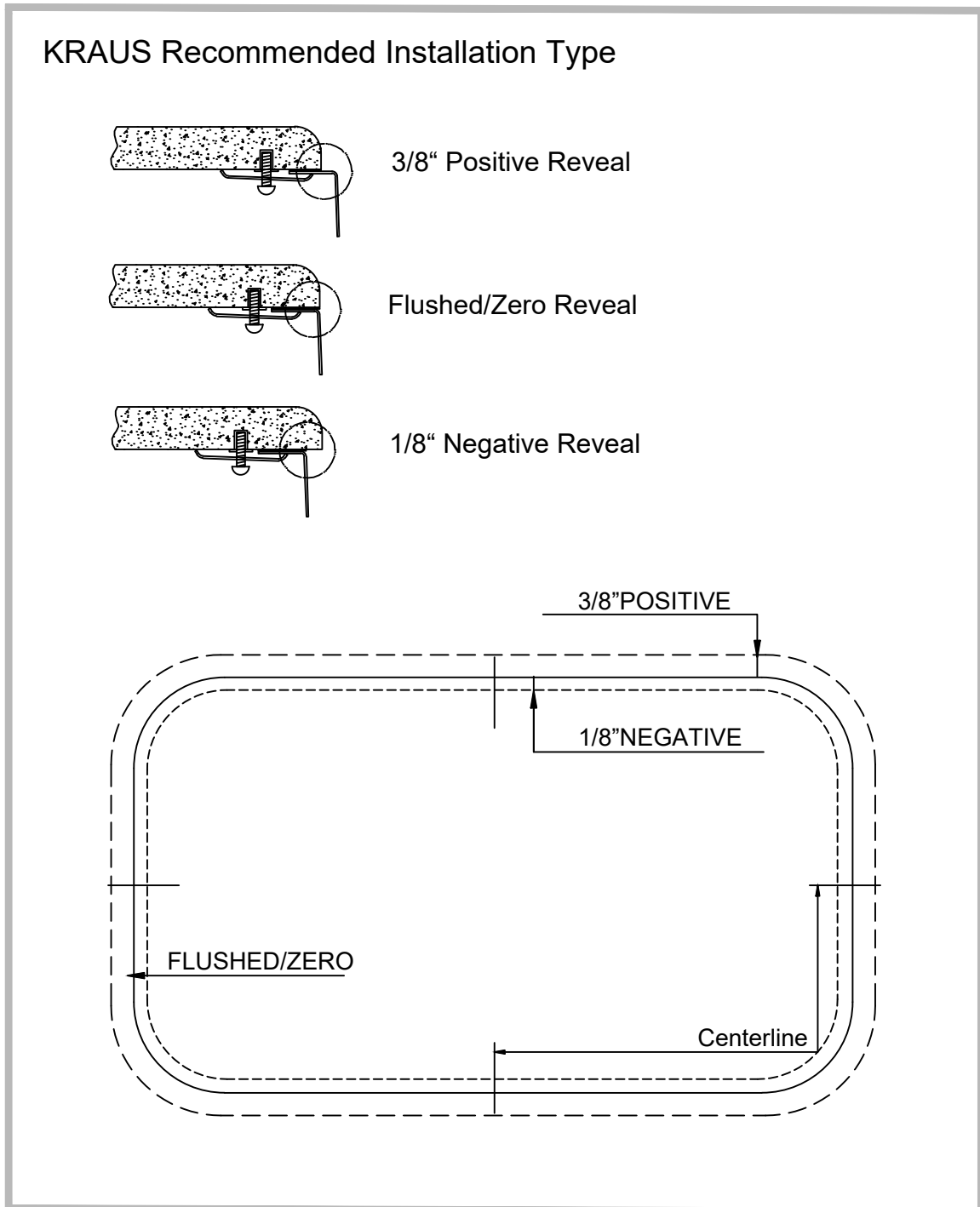

## 2. Position Template

---

- Check the cut-out template against the actual sink to ensure a proper sized cut-out.
- Place the cut-out template in the desired location on the countertop.

**NOTE:** Make sure clearance is suitable for backsplash, faucet and plumbing for the sink.

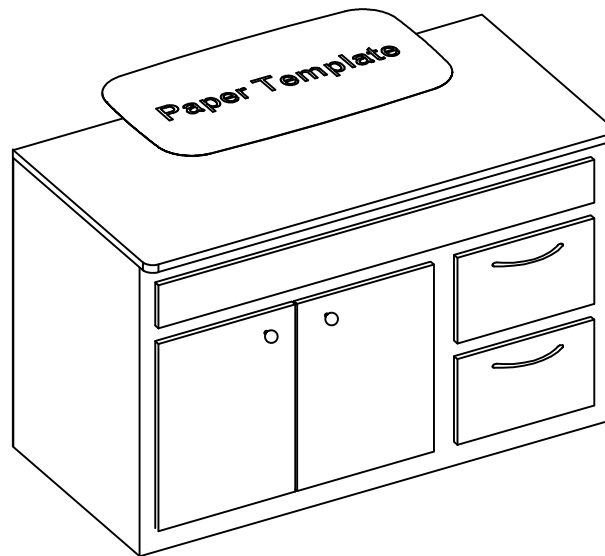

## 3. Trace Template

---

- Trace template on countertop with a pencil.

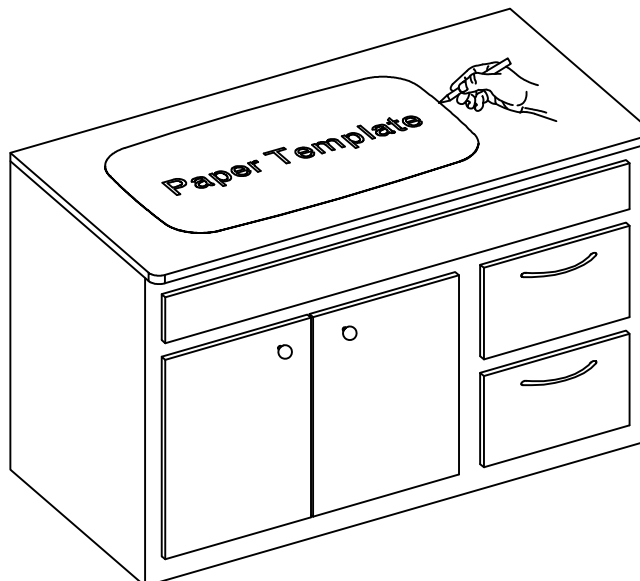

## 4. Cut Countertop

---

- Cut the opening in the countertop by carefully following the traced line.

**NOTE:** Please use the appropriate saw that best fits your countertop material.

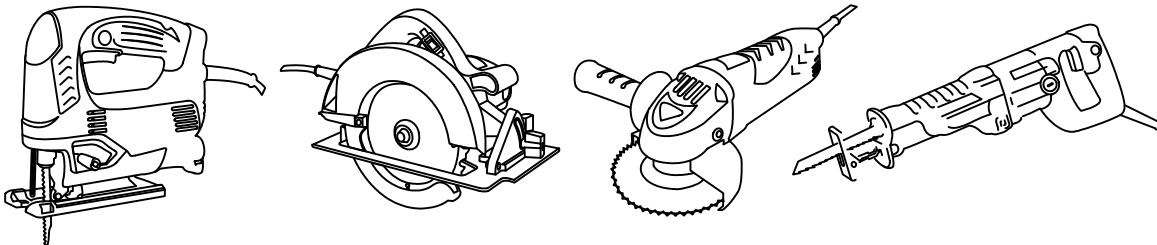
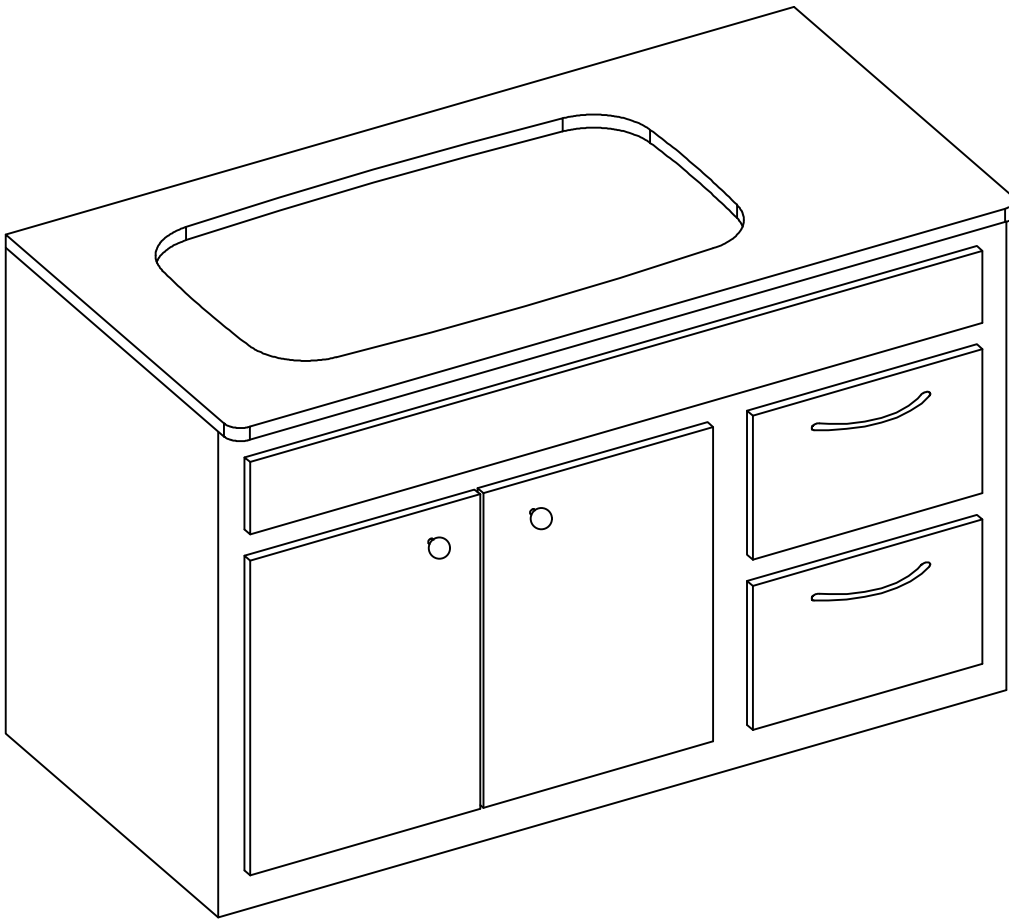



## 5. Set up Mounting Brackets

---

- Turn countertop over and align sink with countertop. Decide location for mounting brackets.
- Mounting holes should be 1/2" from edge of sink.

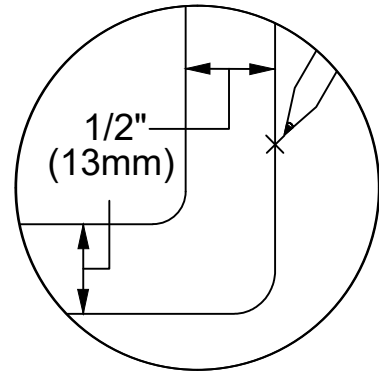
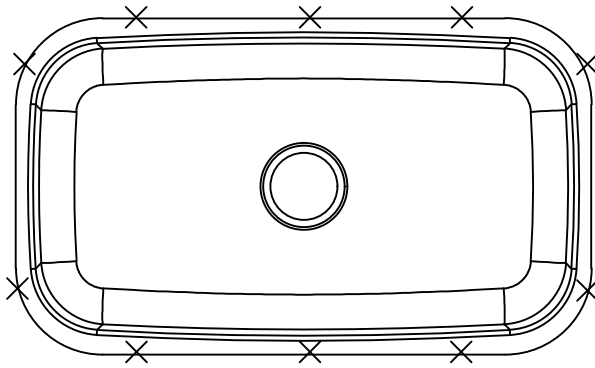

## 6. Drill Hole in Countertop

---

- Drill 3/8" diameter x 1/2" deep hole in countertop.

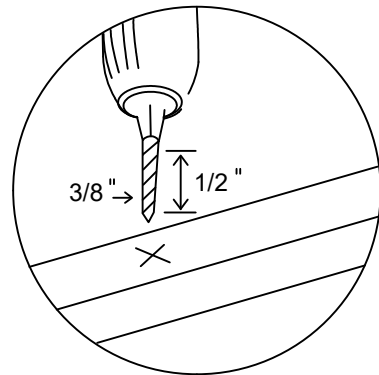
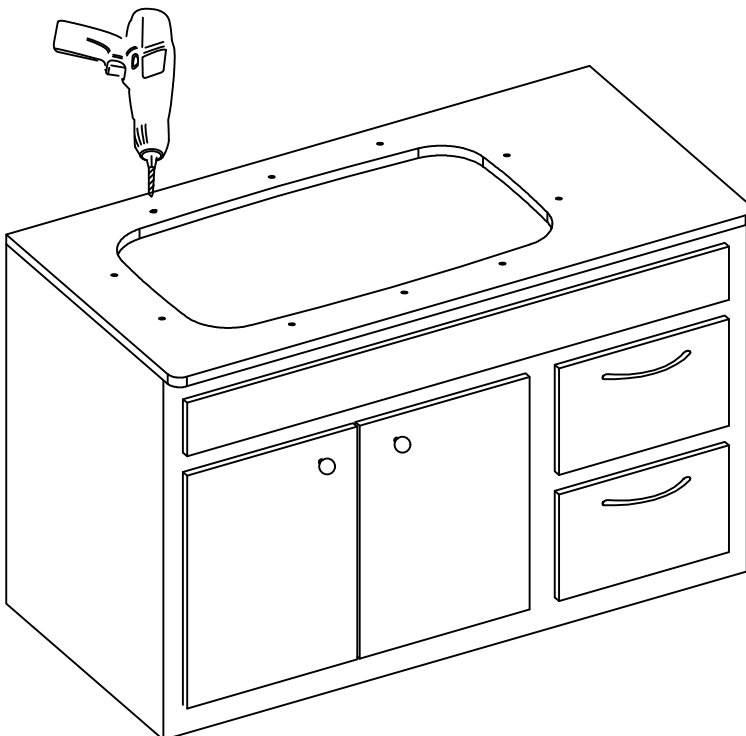

## 7. Install Anchors

---

- Insert anchors into drilled holes and lightly tap with a hammer until flush.

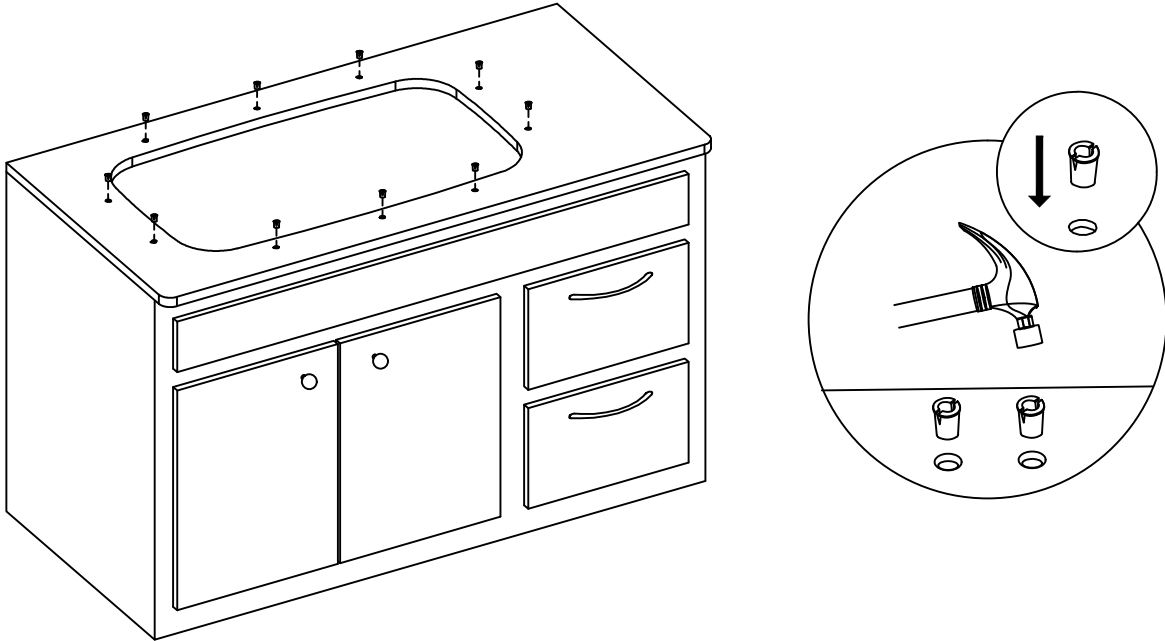

## 8. Secure Sink to Countertop

---

- Use a bead of silicone (or preferred adhesive) around the rim of the sink. Check the alignment of the sink to the cutout in the countertop. Place sink over cutout hole and press firmly.

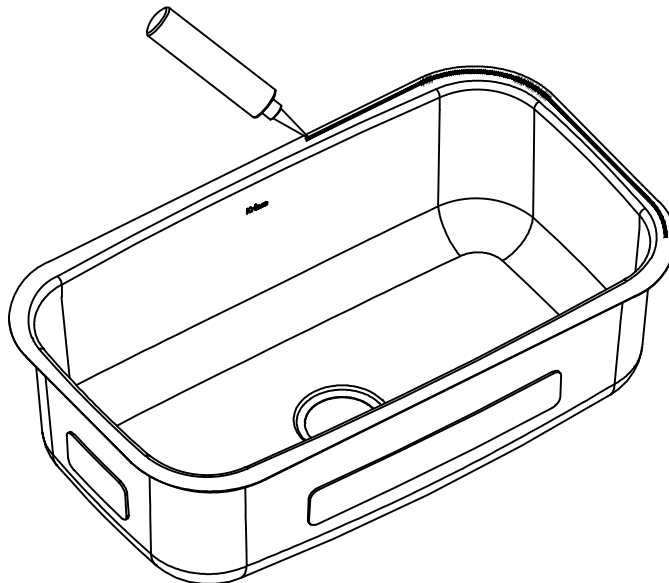

## 9. Attach Mounting Hardware

---

- Attach mounting hardware to secure bowl. Remove excess sealant from inside lip.
- Allow sealant to set for 30 - 60 minutes.

**NOTE:** Use acetone or rubbing alcohol to remove any excess sealant.

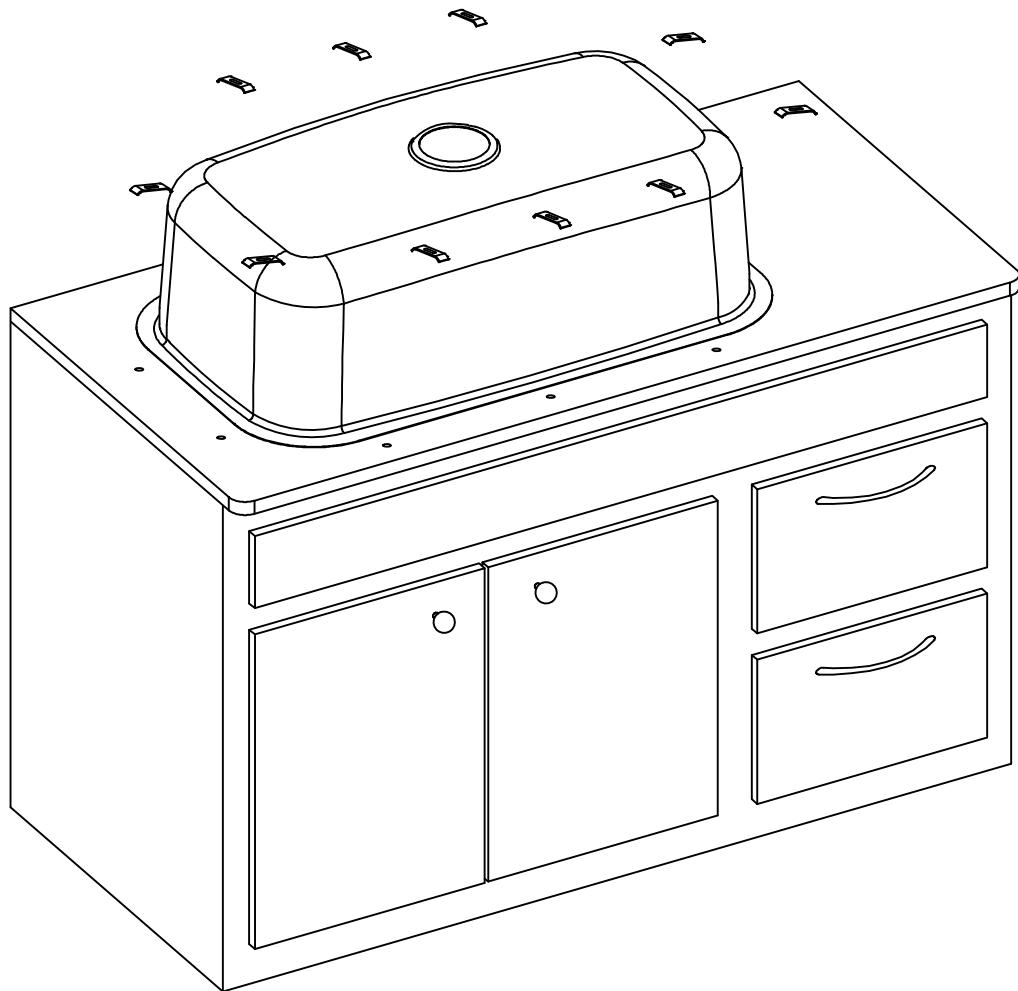

## 10. Install Plumbing Fixtures

---

- Connect drain to sink. Connect trap to drain. Connect water supply connections to faucet according to manufacturer's instructions.
- Run water into sink and check for leaks.
- Note: Before installation, please check that the drain kit complies with ASME A112.18.2/CSA B125.2 and with CUPC certification.

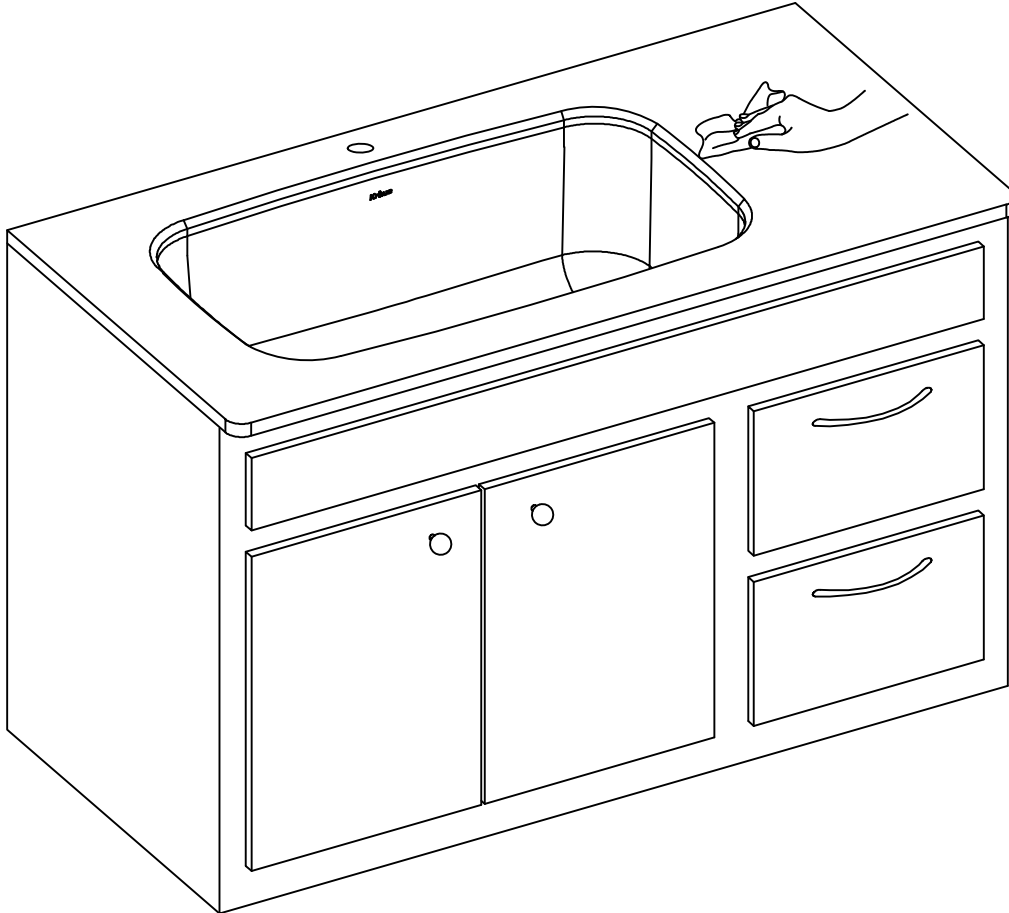

## Maintenance

---

Clean your sink on a regular basis with warm soapy water. Rinse the sink after using cleaning products. Wipe the sink surface with a soft cloth to remove any liquid residue. Do not cut food directly on the surface of the sink. Do not leave sharp objects on the surface of the sink for an extended period of time. Do not use abrasive cleaning products, sanding tools, steel wool, or bleaching products

## Faucet Diagram and Parts List

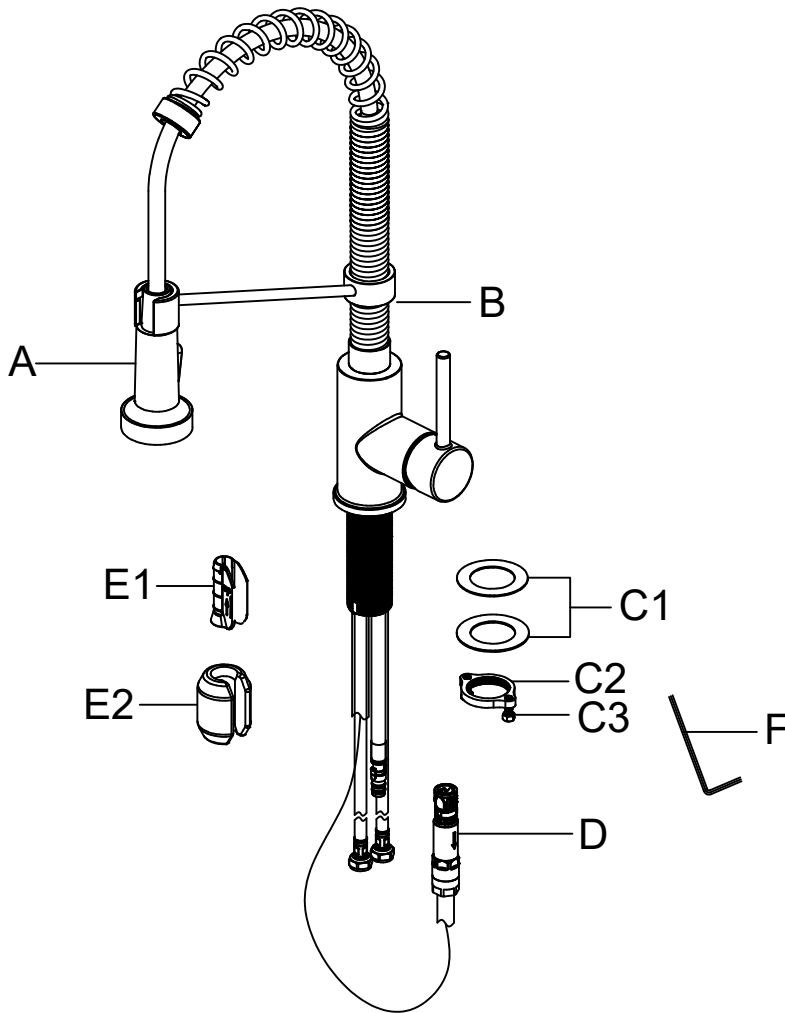

- A. Spray Head
- B. Faucet Body
- C. Mounting Hardware
  - C1. Rubber & Metal Washer
  - C2. Mounting Nut
  - C3. Mounting Screws
- D. Quick Connector
- E. Weight
  - E1. Weight Clip
  - E2. Weight
- F. 2.5mm Hex Wrench

## Faucet Dimensions:

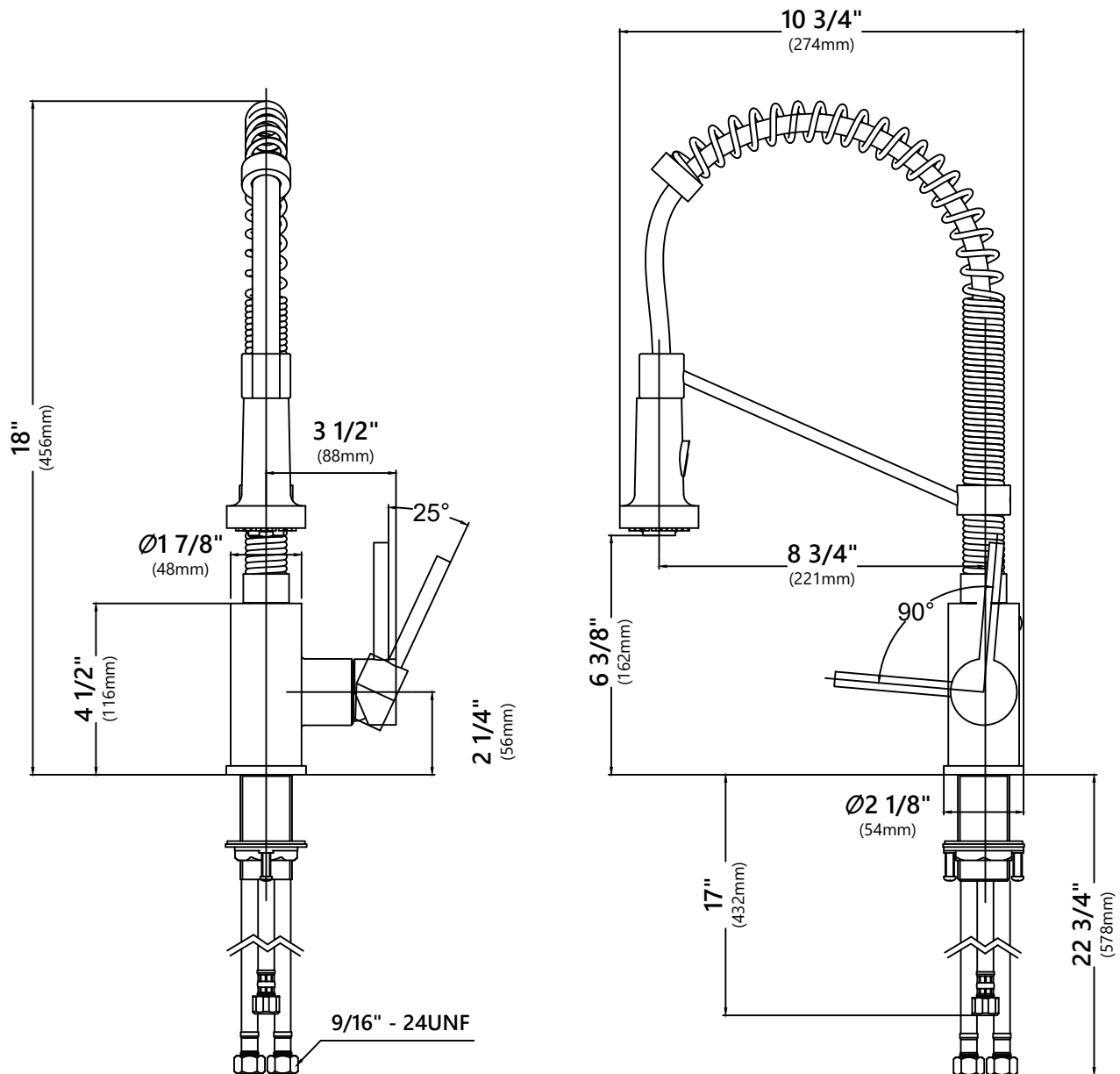

### Installer Tip:

Shut off main water supply before installing new faucet.

## Step 1. Remove mounting hardware

---

Shut off the water supply. Remove the old faucet. Clean the mounting surface. Remove mounting hardware (C) from faucet body (B).

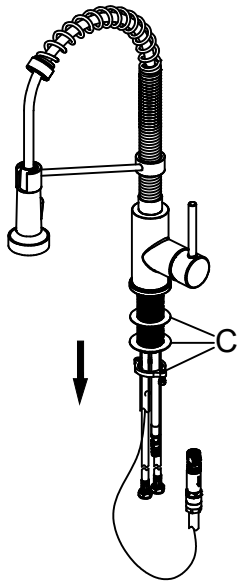

## Step 2. Installing the faucet assembly

---

Optional No Escutcheon Installation.  
Insert faucet body through the hole in the sink.

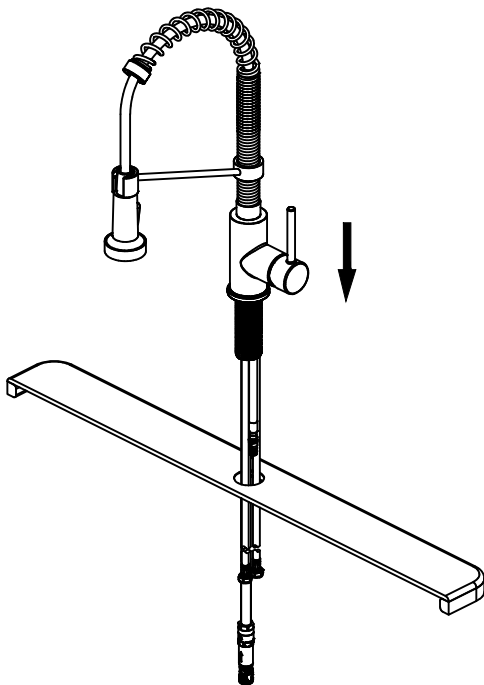

### Step 3. Securing the faucet assembly

---

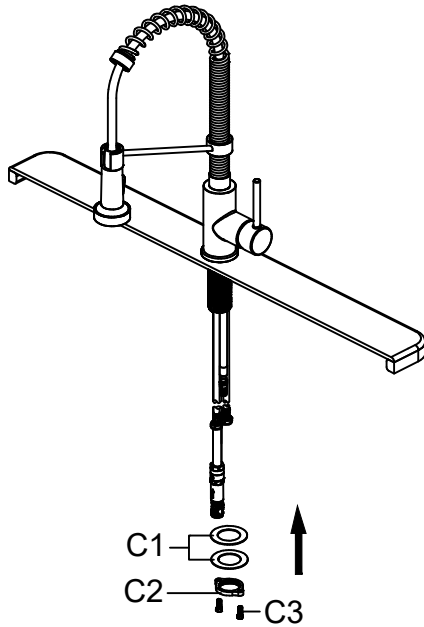

Install the rubber washer and metal washer (C1) onto the threaded mounting shank.

Thread the nut (C2) onto the mounting shank. Lock the nut (C2) into position by tightening the screws (C3). Do not overtighten.

### Step 4. Securing the faucet assembly

---

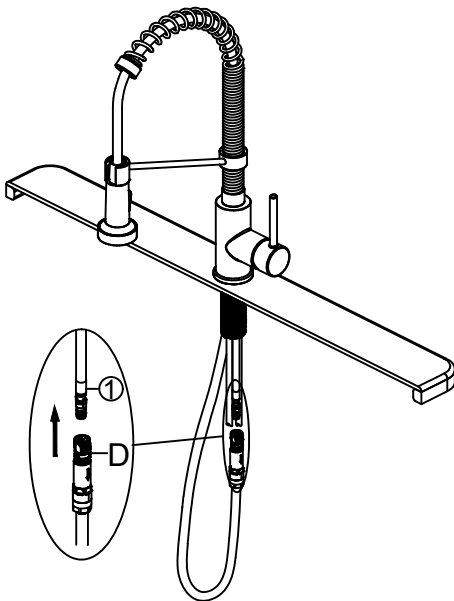

Push the quick connector (D) firmly upward and attach it to the receiving block (1). Pull down moderately to ensure the connection has been made.



## Step 5. Securing the faucet assembly

---

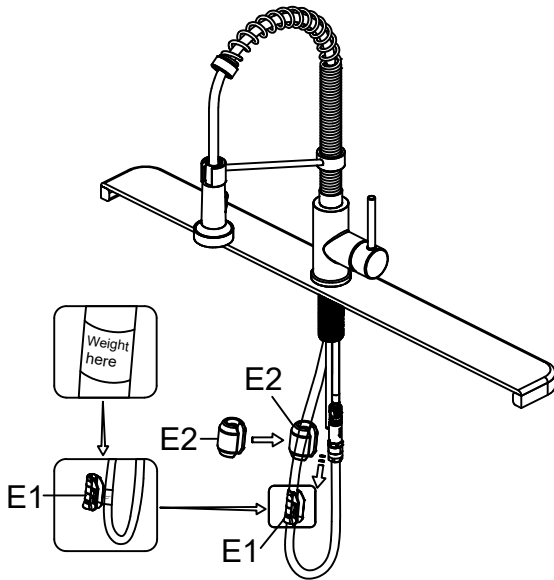

Install the weight clip (E1) at the point of the hose marking "weight here". Insert the weight (E2) onto the clip (E1) by sliding it down onto the clip (E1).

## Step 6. Making the waterline connections

---

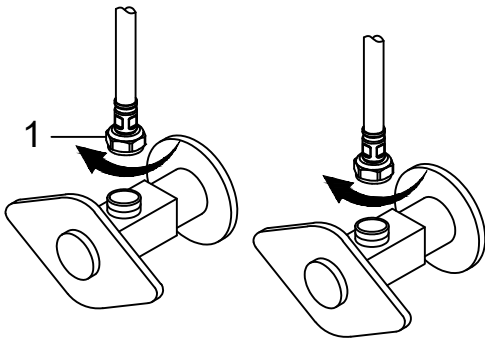

Thread the nut (1) on the supply line onto the outlet of the water supply valve and tighten with a wrench. Do not overtighten.

## Step 7. Flushing and checking for leaks

---

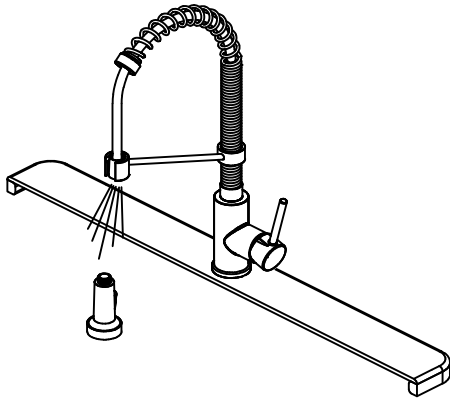

Pull the hose assembly out of the spout and remove the spray head by unscrewing it from the hose in a counterclockwise direction. Be sure to hold the end of the hose down into the sink and turn the faucet on to the warm position where it mixes hot and cold water. Flush the water lines for one minute. This flushes away any debris that could cause damage to internal parts. Check for leaks. Re-tighten any connections if necessary, but do not overtighten. Reinstall the spray head by hand tightening it back onto the spray hose. After installation is completed, turn on the hot and cold water supplies. Check for leaks.

## Troubleshooting

If you have followed the instructions carefully and your faucet still does not work properly, take the following corrective steps:

PROBLEM	CAUSE	ACTION
Leakage under faucet handle	Bonnet nut has come loose	Remove the cover button. Loosen set screw with hex wrench. Remove the handle. Unscrew cap. Tighten bonnet nut with an adjustable wrench.
The aerator has an irregular or reduced water flow	The aerator is dirty or mis-fitted	Remove the aerator and check for debris. Ensure that the rubber washer is properly installed.
The water pressure is low.	The connector underneath the deck is clogged with debris  The aerator is clogged	Turn off the water supply and disconnect the connector / aerator. Unscrew the connector / aerator and clean under running water. Screw the connector / aerator back.  Test water flow. If water pressure is still low then replace the connector / aerator.
There is a low flow of water.	The screen filter in the hose connectors is dirty.	Turn off the water supply at water valve and unscrew the hose connectors from water supply lines. Clean the screen in the water lines with hot water, removing any debris or calcium build up.

## Care & Maintenance

To keep the product clean & shining, follow the steps below:

1. Rinse with clean water & dry with a soft cloth
2. Do not clean with soaps, acid, polish, abrasives or harsh cleaners
3. Do not use cloth with a coarse surface
4. Unscrew the aerator and clean when necessary

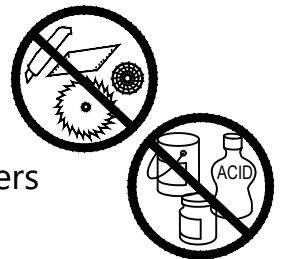

This installation manual is subject to change without further notice.

## Codes/Standards Applicable:



### **Kitchen Sink Warranty**

Kraus products are manufactured and tested to the highest quality standards by Kraus USA Inc. ("Kraus").

Kraus extends this warranty to the original purchaser for personal household use of the "Kitchen Sink" in its original location. The warranty is non-transferable.

Kraus warrants the structure and finish of the product to be free from defects in material and workmanship under normal usage for the lifetime of the product. The warranty commences from the initial date of purchase by the owner or trade professional, from an authorized Kraus dealer, through the lifetime of the original owner or end-user.

Any product reported to the authorized dealer or to Kraus as being defective within the warranty period will be repaired or replaced with a product of equal value at the option of Kraus. This warranty extends to the original owner or end-user, and is not transferable to a subsequent owner.

### **Restrictions**

This warranty does not cover antediluvian, discontinued, or display products, whether such items are purchased at discount outlets, unauthorized dealers, and/or sold on clearance.

This warranty does not cover instances of negligence, misuse, abuse, improper installation, carelessness, accident, hard water or mineral deposits, exposure to corrosive materials, misapplication, damages caused by improper maintenance, alteration of the product, or failure to follow care or installation instructions enclosed with your product. Avoid using abrasive cleaners such as powders, bleach, ammonia, alcohol, or chlorine. Avoid using abrasive pads, steel wool, or wire brushes, as these will damage and wear down the finish.

This warranty does not apply to Products that have not been installed or operated in accordance with instructions supplied by Kraus and all applicable rules, regulations, and legislation pertaining to such installations.

Kraus USA recommends that all Kraus products are installed by fully licensed and insured trade professionals with experience in the installation of bathroom and/or kitchen manufactured goods.

This warranty does not cover labor charges or costs of removal and reinstallation of said product. This warranty does not allow recovery of incidental or consequential damages, such as loss of use, delay, property damage, or other consequential damages, and Kraus accepts no liability for such damages.

This warranty does not cover Marine or Outdoor Installation.

This warranty does not cover any free gifts included with purchase.

Except as otherwise provided above, Kraus makes no warranties, expressed or implied, including warranties of merchantability and fitness for a particular purpose, or compliance with any code.

Shipping charges will be covered for the first (1) year of the warranted replacement part or product (HI, AK, and Puerto Rico shipping charges may apply). International shipping fees are not included.

### **Commercial Warranty**

Kraus extends the above warranty for a period of one (1) year to purchasers of products for industrial, commercial, and business use.

All incidental or consequential damages are specifically excluded. No additional warranties, express or implied, are given, including but not limited to any implied warranty of merchantability or fitness for a particular purpose.

Some states do not allow the exclusion or limitation of incidental or consequential damages or limitations on how long an implied warranty lasts, so the above limitations or exclusions may not apply to you.

This warranty gives you specific legal rights, and you may also have other rights which vary from state to state.

KRAUS USA has the right to change, modify, and/or update the warranty policy at any time. For the latest, most up to date comprehensive warranty, go to [www.kraususa.com/warranty](http://www.kraususa.com/warranty)

## Codes/Standards Applicable:



ASME A112.18.1  
1.8GPM 6.8L/min maximum

### FAUCET WARRANTY

Kraus products are manufactured and tested to the highest quality standards by Kraus USA Inc. ("Kraus").

Kraus extends this warranty to the original purchaser for personal household use of the "Faucet" in its original location. The warranty is non-transferable.

Kraus warrants the structure and finish of the product to be free from defects in material and workmanship under normal usage for the lifetime of the product. The warranty commences from the initial date of purchase by the owner or trade professional, from an authorized Kraus dealer, through the lifetime of the original owner or end-user.

Kraus warrants the mechanical components such as but not limited to sprayhead assembly (includes engine, aerators, structure, restrictors, back flow preventers, sprayer hoses, braided supply line hoses which encompasses nylon, silicon and stainless steel, etc) of the product to be free from defects in material and workmanship under normal usage for a period of one (1) year. The warranty commences from the initial date of purchase by the owner or trade professional, from an authorized Kraus dealer, through the one (1) year term of the original owner or end-user.

Kraus warrants the mechanical component (cartridge) of the product to be free from defects in material and workmanship under normal usage for a period of five (5) years. The warranty commences from the initial date of purchase by the owner or trade professional, from an authorized Kraus dealer, through the five (5) year term of the original owner or end-user.

Any product reported to the authorized dealer or to Kraus as being defective within the warranty period will be repaired or replaced with a product of equal value at the option of Kraus. This warranty extends to the original owner or end-user, and is not transferable to a subsequent owner.

### RESTRICTIONS

This warranty does not cover antediluvian, discontinued, or display products, whether such items are purchased at discount outlets, unauthorized dealers, and/or sold on clearance.

This warranty does not cover instances of negligence, misuse, abuse, improper installation, carelessness, accident, hard water or mineral deposits, exposure to corrosive materials, misapplication, damages caused by improper maintenance, alteration of the product, or failure to follow care or installation instructions enclosed with your product. Avoid using abrasive cleaners such as powders, bleach, ammonia, alcohol, or chlorine. Avoid using abrasive pads, steel wool, or wire brushes, as these will damage and wear down the finish.

This warranty does not apply to Products that have not been installed or operated in accordance with instructions supplied by Kraus and all applicable rules, regulations, and legislation pertaining to such installations.

Kraus USA recommends that all Kraus products are installed by fully licensed and insured trade professionals with experience in the installation of bathroom and/or kitchen manufactured goods.

This warranty does not cover labor charges or costs of removal and reinstallation of said product. This warranty does not allow recovery of incidental or consequential damages, such as loss of use, delay, property damage, or other consequential damages, and Kraus accepts no liability for such damages.

This warranty does not cover Marine or Outdoor Installation.

Except as otherwise provided above, Kraus makes no warranties, expressed or implied, including warranties of merchantability and fitness for a particular purpose, or compliance with any code.

Shipping charges will be covered for the first (1) year of the warranted replacement part or product (HI, AK, and Puerto Rico shipping charges may apply). International shipping fees are not included.

## **COMMERCIAL WARRANTY**

Kraus extends the above warranty for a period of one (1) year to purchasers of products for industrial, commercial, and business use.

All incidental or consequential damages are specifically excluded. No additional warranties, express or implied, are given, including but not limited to any implied warranty of merchantability or fitness for a particular purpose.

Some states do not allow the exclusion or limitation of incidental or consequential damages or limitations on how long an implied warranty lasts, so the above limitations or exclusions may not apply to you.

This warranty gives you specific legal rights, and you may also have other rights which vary from state to state.

KRAUS USA has the right to change, modify, and/or update the warranty policy at any time. For the latest, most up to date comprehensive warranty, go to [www.kraususa.com/warranty](http://www.kraususa.com/warranty)

### **If you are a homeowner please contact a Kraus Customer Service Representative at:**

Kraus USA, Inc.  
12 Harbor Park Drive  
Port Washington, NY 11050  
Toll-free 800-775-0703  
Customerservice@kraususa.com

### **If you are a plumbing contractor or trade professional please contact a Kraus Pro Representative at:**

Kraus USA, Inc.  
12 Harbor Park Drive  
Port Washington, NY 11050  
516-801-8955  
Proservice@kraususa.com

**If you are an Authorized Partner please contact a Partner Support Representative at:**

Kraus USA, Inc.  
12 Harbor Park Drive  
Port Washington, NY 11050  
516-801-8954  
Partnersupport@kraususa.com

**In requesting warranty service, please be ready to provide:**

1. Proof of purchase.
2. A description of the problem.

**Download the Kraus Care & Maintenance Guide at:**  
<http://www.kraususa.com/maintenance>

# IMPORTANT

## Register Your Kraus Product

**Activate** Your Warranty

**Access** Premium Customer Support

**Get** Product Information

**REGISTER TODAY**

<http://www.kraususa.com/registration>



**Kräus**<sup>®</sup>  
www.kraususa.com





INSTALLATION GUIDE

## Kitchen Strainer

ST-1 / ST-2 / ST-3 / BST-1 / BST-2

## **Congratulations on the purchase of your new Kraus plumbing fixture!**

Please keep the box and packaging materials until your product is completely installed. If you have any questions, require technical assistance or have any problems with your product:



**DO NOT RETURN TO STORE**

**Please contact our Customer Service Team  
1-800-775-0703 / [customerservice@kraususa.com](mailto:customerservice@kraususa.com)**

Have the model number available and retain a copy of your receipt with purchase date for reference.

If for any reason this product does not meet your expectations, please be sure to repack this product in the original box and packaging material to avoid damage during transit.

### **Prior to Installation:**

- Make sure you have all necessary parts by checking the diagram and parts list. If any part is missing or damaged, please contact Kraus Customer Service at 800-775-0703 for a replacement.

**For technical assistance or replacement parts, please contact Kraus Customer Service and one of our representatives will be happy to help:**  
Toll-Free: 800-775-0703 or [Customerservice@kraususa.com](mailto:Customerservice@kraususa.com)

The step-by-step guidelines in the installation instructions are a general reference for installing a Kraus Sink. Should there be any discrepancies, Kraus cannot be held liable. It is recommended to install all Kraus products by hiring a licensed professional.

### **Tools you will need:**



Safety Goggles



Phillips Screwdriver

## Diagram and Parts List

ST-1

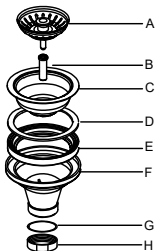

- A. Strainer Cover
- B. Screw
- C. Metal Strainer
- D. Foam Gasket
- E. Rubber Gasket
- F. Main Body
- G. Drain Gasket
- H. Drain Nut

ST-2

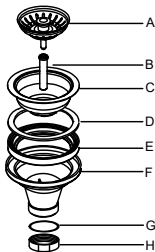

- A. Strainer Cover
- B. Screw
- C. Metal Strainer
- D. Foam Gasket
- E. Rubber Gasket
- F. Main Body
- G. Drain Gasket
- H. Drain Nut

## Diagram and Parts List

BST-1

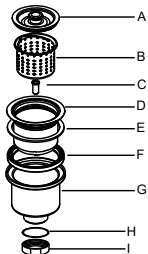

- A. Strainer Cover
- B. Basket
- C. Screw
- D. Metal Strainer
- E. Foam Gasket
- F. Rubber Gasket
- G. Main Body
- H. Drain Gasket
- I. Drain Nut

BST-2

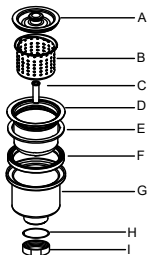

- A. Strainer Cover
- B. Basket
- C. Screw
- D. Metal Strainer
- E. Foam Gasket
- F. Rubber Gasket
- G. Main Body
- H. Drain Gasket
- I. Drain Nut

## Diagram and Parts List

ST-3

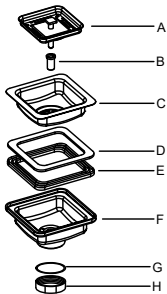

- A. Strainer Cover
- B. Screw
- C. Metal Strainer
- D. Foam Gasket
- E. Rubber Gasket
- F. Main Body
- G. Drain Gasket
- H. Drain Nut

## Dimensions

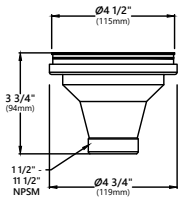

Model #: ST-1  
Dimensions:  $\varnothing 4 \frac{1}{2}'' \times 3 \frac{3}{4}''$

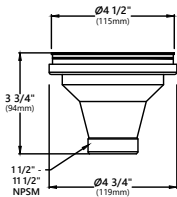

Model #: ST-2  
Dimensions:  $\varnothing 4 \frac{1}{2}'' \times 3 \frac{3}{4}''$

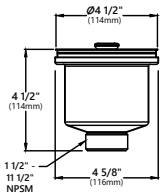

Model #: BST-1  
Dimensions:  $\varnothing 4 \frac{1}{2}'' \times 4 \frac{1}{2}''$

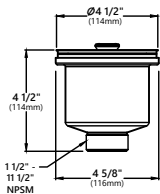

Model #: BST-2  
Dimensions:  $\varnothing 4 \frac{1}{2}'' \times 4 \frac{1}{2}''$

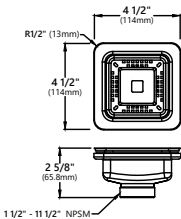

Model #: ST-3  
Dimensions:  $4 \frac{1}{2}'' \times 4 \frac{1}{2}'' \times 2 \frac{5}{8}''$

## Step 1.

---

Disassemble strainer





## Step 2.

---

Insert metal strainer into drain hole with foam gasket attached. Install rubber gasket and main body underneath the sink

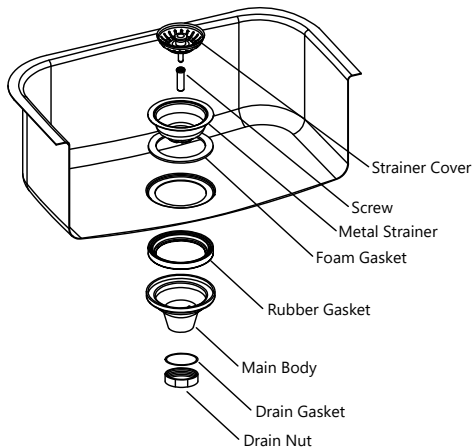

Step 3.

---

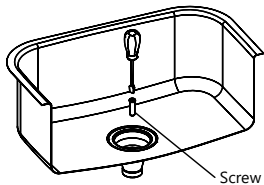

Using the screw, tighten the metal strainer and main body into place

Step 4.

---

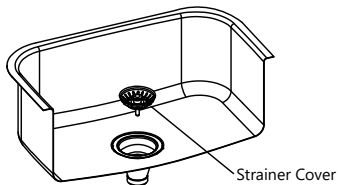

Insert strainer cover to seal water

## Replacement Parts

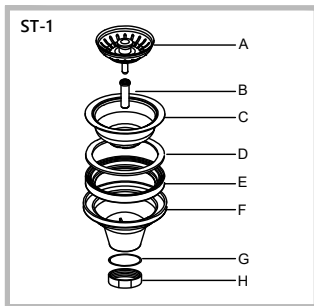

Replacement Parts List	Finish	Part #
A. Strainer Cover	SS*	KPU00010
A. Strainer Cover	PGM*	KPU00010-PGM
B. Screw 1 1/4"	SS*	KPU00003
B. Screw 1 1/4"	PGM*	KPU00003-PGM
C. Metal Strainer	SS*	KPU00011
C. Metal Strainer	PGM*	KPU00011-PGM
D. Foam Gasket		KPU00005
E. Rubber Gasket		KPU00006
F. Main Body		KPU00012
G. Drain Gasket		KPU00008
H. Drain Nut		KPU00009

\*Denotes faucet component color options:

SS - Stainless Steel

PGM - PVD Gunmetal

## Replacement Parts

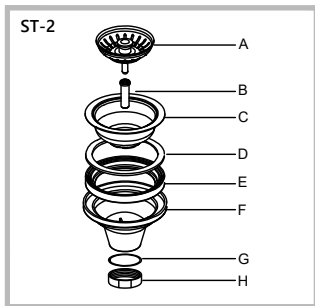

Replacement Parts List	Finish	Part #
A. Strainer Cover		KPU00010
B. Screw 1 5/8"		KPU00013
C. Metal Strainer		KPU00011
D. Foam Gasket		KPU00005
E. Rubber Gasket		KPU00006
F. Main Body		KPU00012
G. Drain Gasket		KPU00008
H. Drain Nut		KPU00009

## Replacement Parts

**BST-1**

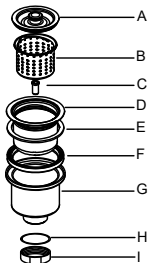

Replacement Parts List	Finish	Part #
A. Strainer Cover		KPU00001
B. Basket		KPU00002
C. Screw 1 1/4"		KPU00003
D. Metal Strainer		KPU00004
E. Foam Gasket		KPU00005
F. Rubber Gasket		KPU00006
G. Main Body		KPU00007
H. Drain Gasket		KPU00008
I. Drain Nut		KPU00009

**BST-2**

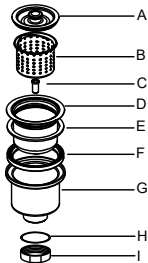

Replacement Parts List	Finish	Part #
A. Strainer Cover		KPU00001
B. Basket		KPU00002
C. Screw 1 5/8"		KPU00013
D. Metal Strainer		KPU00004
E. Foam Gasket		KPU00005
F. Rubber Gasket		KPU00006
G. Main Body		KPU00007
H. Drain Gasket		KPU00008
I. Drain Nut		KPU00009

## Replacement Parts

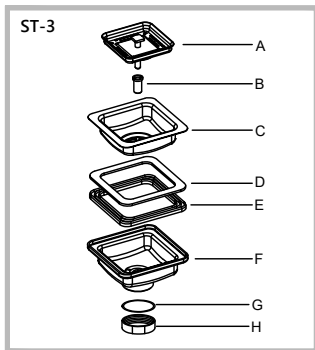

Replacement Parts List	Finish	Part #
A. Strainer Cover		KP22191
B. Screw		KP22198
C. Metal Strainer		KP22192
D. Foam Gasket		KP22193
E. Rubber Gasket		KP22194
F. Main Body		KP22195
G. Drain Gasket		KP22196
H. Drain Nut		KP22197

## Accessories Warranty

Kraus products are manufactured and tested to the highest quality standards by Kraus USA Inc. ("Kraus").

Kraus extends this warranty to the original purchaser for personal household use of the "Accessories" in their original location. The warranty is non-transferable.

Kraus warrants the structure and finish of the product (Accessories) to be free from defects in material and workmanship under normal usage for a period of one (1) years. The warranty commences from the initial date of purchase by the owner or trade professional, from an authorized Kraus dealer, through the one (1) year term of the original owner or end-user.

Any product reported to the authorized dealer or to Kraus as being defective within the warranty period will be repaired or replaced with a product of equal value at the option of Kraus. This warranty extends to the original owner or end-user, and is not transferable to a subsequent owner.

## Restrictions

This warranty does not cover antediluvian, discontinued, or display products, whether such items are purchased at discount outlets, unauthorized dealers, and/or sold on clearance.

This warranty does not cover instances of negligence, misuse, abuse, improper installation, carelessness, accident, hard water or mineral deposits, exposure to corrosive materials, misapplication, damages caused by improper maintenance, alteration of the product, or failure to follow care or installation instructions enclosed with your product. Avoid using abrasive cleaners such as powders, bleach, ammonia, alcohol, or chlorine. Avoid using abrasive pads, steel wool, or wire brushes, as these will damage and wear down the finish.

Kraus USA recommends that all Kraus products are installed by fully licensed and insured trade professionals with experience in the installation of bathroom and/or kitchen manufactured goods.

This warranty does not cover labor charges or costs of removal and reinstallation of said product. This warranty does not allow recovery of incidental or consequential damages such as loss of use, delay, property damage, or other consequential damages, and Kraus accepts no liability for such damages.

This warranty does not cover Marine or Outdoor Installation.

Except as otherwise provided above, Kraus makes no warranties, expressed or implied, including warranties of merchantability and fitness for a particular purpose, or compliance with any code.

Shipping charges will be covered for the first (1) year of the warranted replacement part or product (HI, AK, and Puerto Rico shipping charges may apply). International shipping fees are not included.

## Commercial Warranty

Kraus extends the above warranty for a period of one (1) year to purchasers of products for industrial, commercial, and business use.

All incidental or consequential damages are specifically excluded. No additional warranties, express or implied, are given, including but not limited to any implied warranty of merchantability or fitness for a particular purpose.

Some states do not allow the exclusion or limitation of incidental or consequential damages, or limitations on how long an implied warranty lasts, so the above limitations or exclusions may not apply to you.

This warranty gives you specific legal rights, and you may also have other rights which vary from state to state.

KRAUS USA has the right to change, modify, and/or update the warranty policy at any time. For the latest, most up to date comprehensive warranty, go to [www.kraususa.com/warranty](http://www.kraususa.com/warranty)

If you are a **HOMEOWNER**, please contact a Kraus Customer Service Representative at:

Kraus USA, Inc.  
12 Harbor Park Drive  
Port Washington, NY 11050  
Toll-Free : 800-775-0703  
Customerservice@kraususa.com

If you are a **PLUMBING CONTRACTOR OR TRADE PROFESSIONAL**, please contact a Kraus Pro Representative at:

Kraus USA, Inc.  
12 Harbor Park Drive  
Port Washington, NY 11050  
516-801-8955  
Proservice@kraususa.com

If you are an **AUTHORIZED PARTNER**, please contact a Partner Support Representative at:

Kraus USA, Inc.  
12 Harbor Park Drive  
Port Washington, NY 11050  
516-801-8954  
Partnersupport@kraususa.com

In requesting warranty service, please be ready to provide:

1. Proof of purchase
2. A description of the problem

**Download the Kraus Care & Maintenance Guide at:**  
<http://www.kraususa.com/maintenance>



# IMPORTANT

## Register Your Kraus Product

**Activate** Your Warranty

**Access** Premium Customer Support

**Get** Product Information

**REGISTER TODAY**

**<http://www.kraususa.com/registration>**



**Kräus**  
www.kraususa.com