



Packaged Sewage System

MODEL

SWW0511AC

APPLICATIONS

- For home, rural water districts, parks, and dewatering
- Waste water
- Sewage lift station
- Anywhere waste or drainage must be disposed of quickly, quietly and efficiently

SPECIFICATIONS

Pump:

- ½ HP, 115 V, 1 PH, 1550 RPM, with 20 foot power cord.
- Built in overload protection. Max amps: 13.0.

Motor:

- Capacities: up to 70 GPM.
- Total heads: up to 18 feet.
- Factory preset mechanical float switch with piggy-back plug.
- 2" maximum solids handling capability.

Basin:

- 4" inlet connection.
- Height: 30"
- Width: 22"
- Weight: 46 lbs.
- 30 gallon basin capacity.

FEATURES

- Fully assembled at factory for simplified handling and easy installation.
- Torque stops located in tank base for stability of the installed pump.
- Full vortex design impeller.
- Piggy-back plug design allows for automatic or manual operation of pump.

- Capable of running dry without damage to components.

ASSEMBLED COMPONENTS

- WW0511AC*, ½ HP, 2" solids handling pump.
- A2-9F mechanical tilt switch with 20 foot cord.
- 18" x 30" polyethylene roll top basin.
- 18" single piece, 14 gauge steel cover.
- 2" vent and discharge connections.
- 2" schedule 40 PVC discharge pipe.

Also includes 2" flapper check valve boxed separately.

* CSA listed pump.

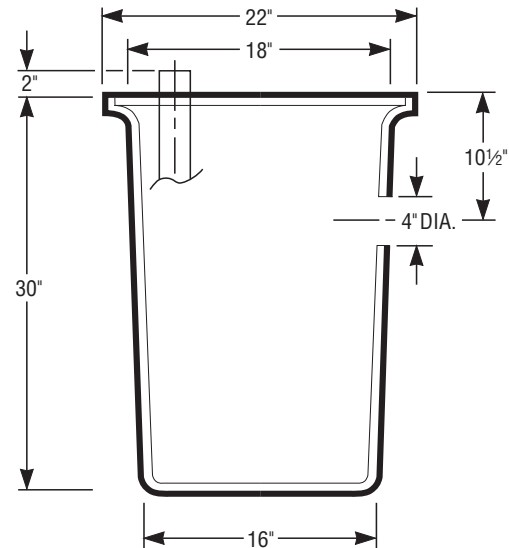

Order No.	HP	Volts	Max. Amps	Discharge	Vent	Wt. (lbs.)
SWW0511AC	½	115	13.0	2"	2"	46
SWW0511AC3					3"	

