

4

3

2

1

**BILL OF MATERIAL (CURRENT LEVEL)**

ITEM	PT/ASSY	DESCRIPTION	TYPE	QTY.
1	1-500	T/S 2 - VALVE ROUGH	ASSEMBLY	1
2	3-995	TRIM KIT - 3-995	ASSEMBLY	1

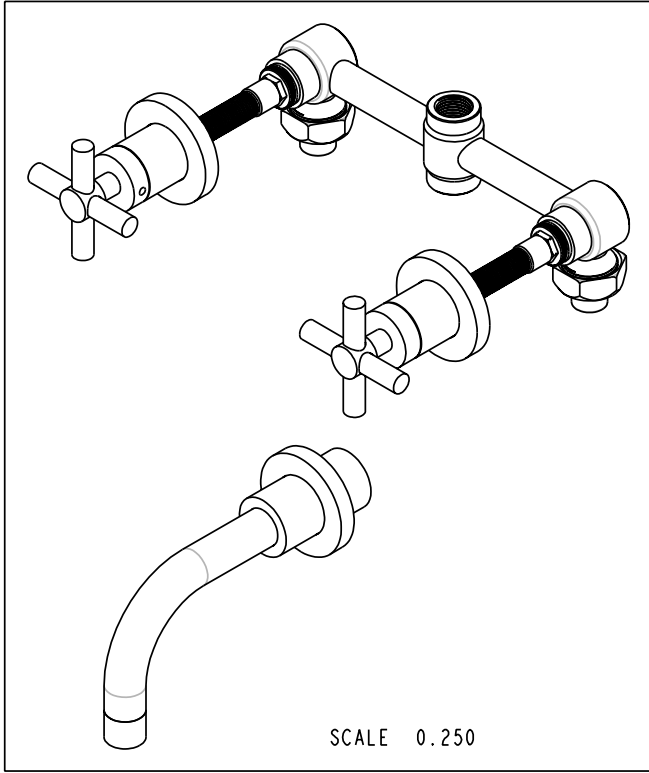
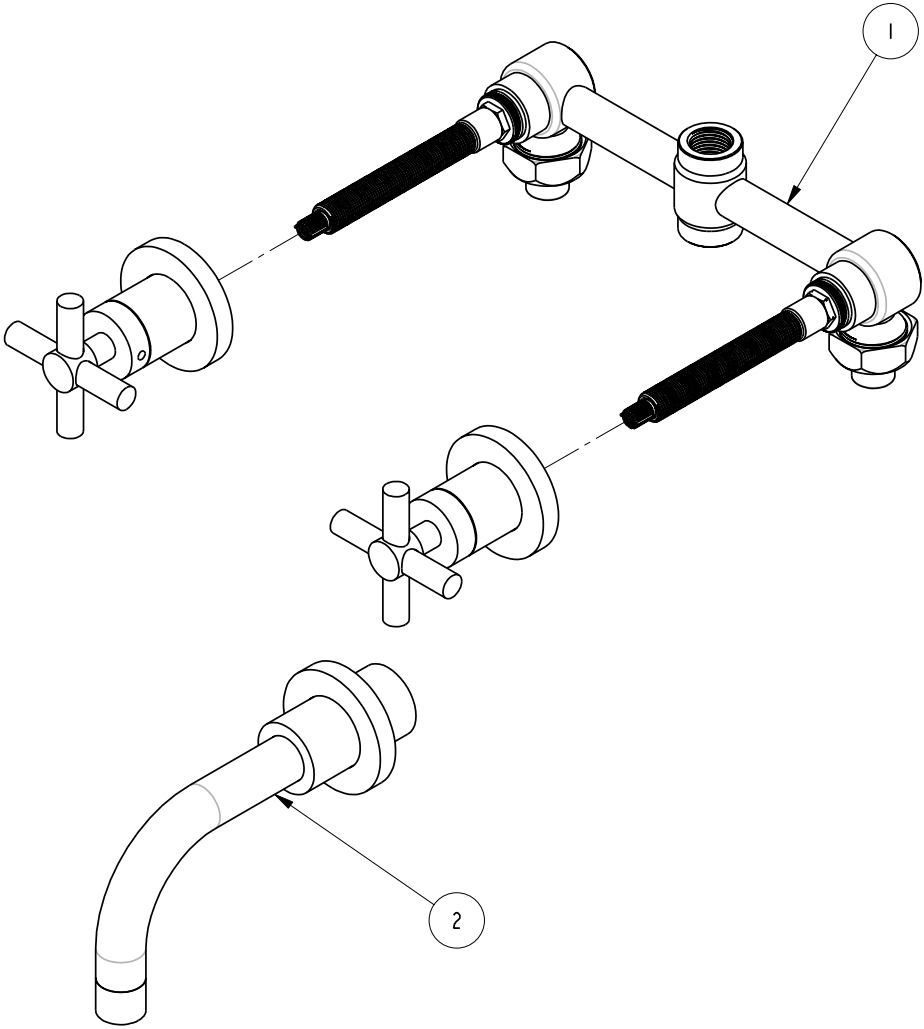

NOTE: RECOMMENDED VALVE(S), SHOWN WITH TRIM KIT, SOLD SEPARATELY.

COPYRIGHT 2005 BRASSTECH, INC. THESE DRAWINGS AND THE DESIGNS DEPICTED HEREIN ARE THE PROPRIETARY PROPERTY OF BRASSTECH. ANY USE OR REPRODUCTION IS SUBJECT TO THE EXPRESS APPROVAL OF BRASSTECH. UNAUTHORIZED USE IS STRICTLY PROHIBITED. ALL RIGHTS RESERVED.

**BRASSTECH**  
 INCORPORATED  
 2001 E. CARNEGIE AVE.  
 SANTA ANA, CA 92705  
 (949) 417-5207

TUB SET

ASSY. NO.	995	-	-	-
SCALE 0.300	REF. -	SHEET 1 OF 3	REV	REV DESC
			EN-1167	12/19/08
			DATE	

4

3

2

1

4

3

2

1

**BILL OF MATERIAL (CURRENT LEVEL)**

ITEM	PT/ASSY	DESCRIPTION	TYPE	QTY.
1	3-234	WALL TUB SPOUT ASM	ASSEMBLY	1
2	3-227	HANDLE TRIM - STOP VALVE	ASSEMBLY	2

D

D

C

C

B

B

A

A

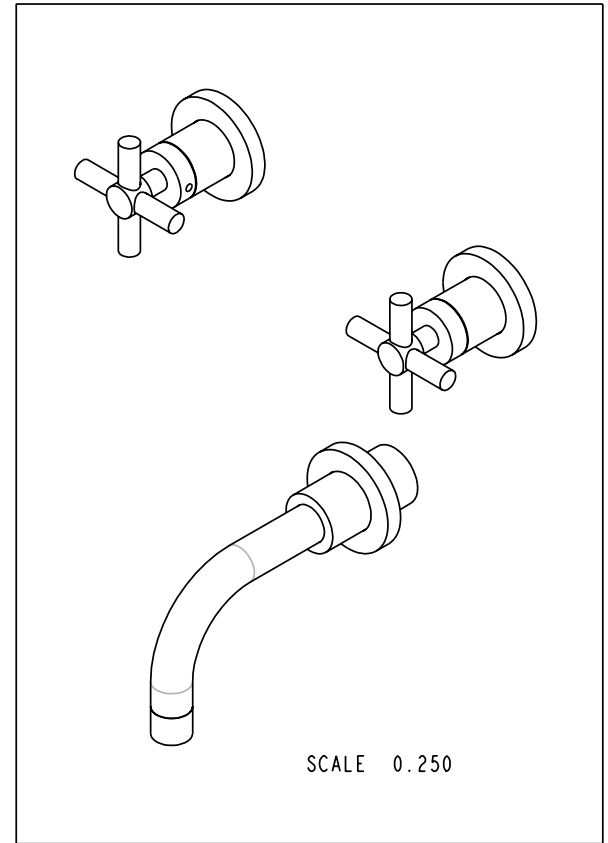
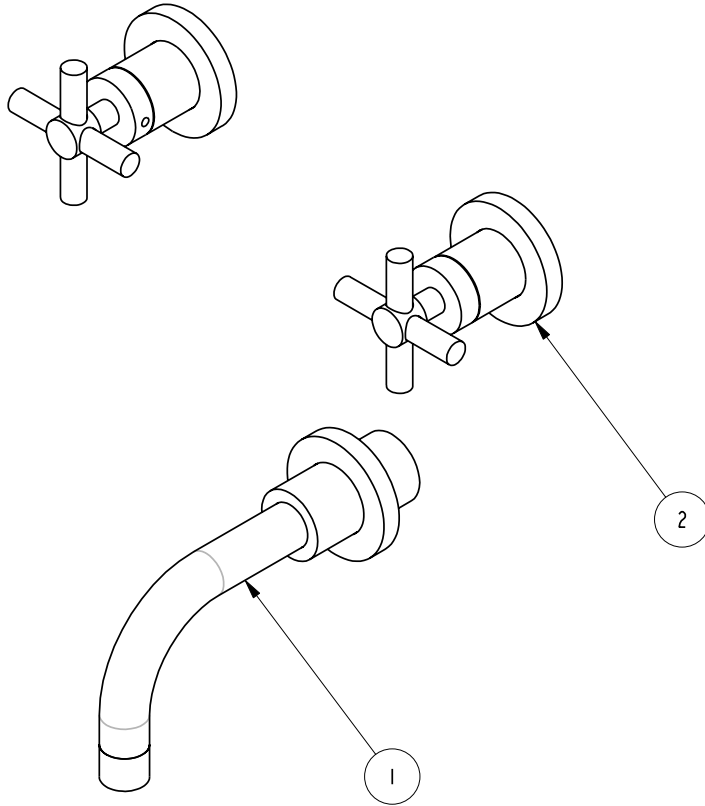

COPYRIGHT 2005 BRASSTECH, INC. THESE DRAWINGS AND THE DESIGNS DEPICTED HEREIN ARE THE PROPRIETARY PROPERTY OF BRASSTECH. ANY USE OR REPRODUCTION IS SUBJECT TO THE EXPRESS APPROVAL OF BRASSTECH. UNAUTHORIZED USE IS STRICTLY PROHIBITED. ALL RIGHTS RESERVED.

**BRASSTECH**  
 INCORPORATED  
 2001 E. CARNEGIE AVE.  
 SANTA ANA, CA 92705  
 (949) 417-5207

TRIM KIT - 3-995

ASSY. NO.	995	-	-	-
SCALE 0.300	REF. -	SHEET 2 OF 3	REV	REV DESC
			EN-1167	12/19/08
			DATE	

4

3

2

1

**SPECIFICATION DWG**

NOTES:  
1. CUT ALL-THREAD 1/2" SHORTER THAN STEM

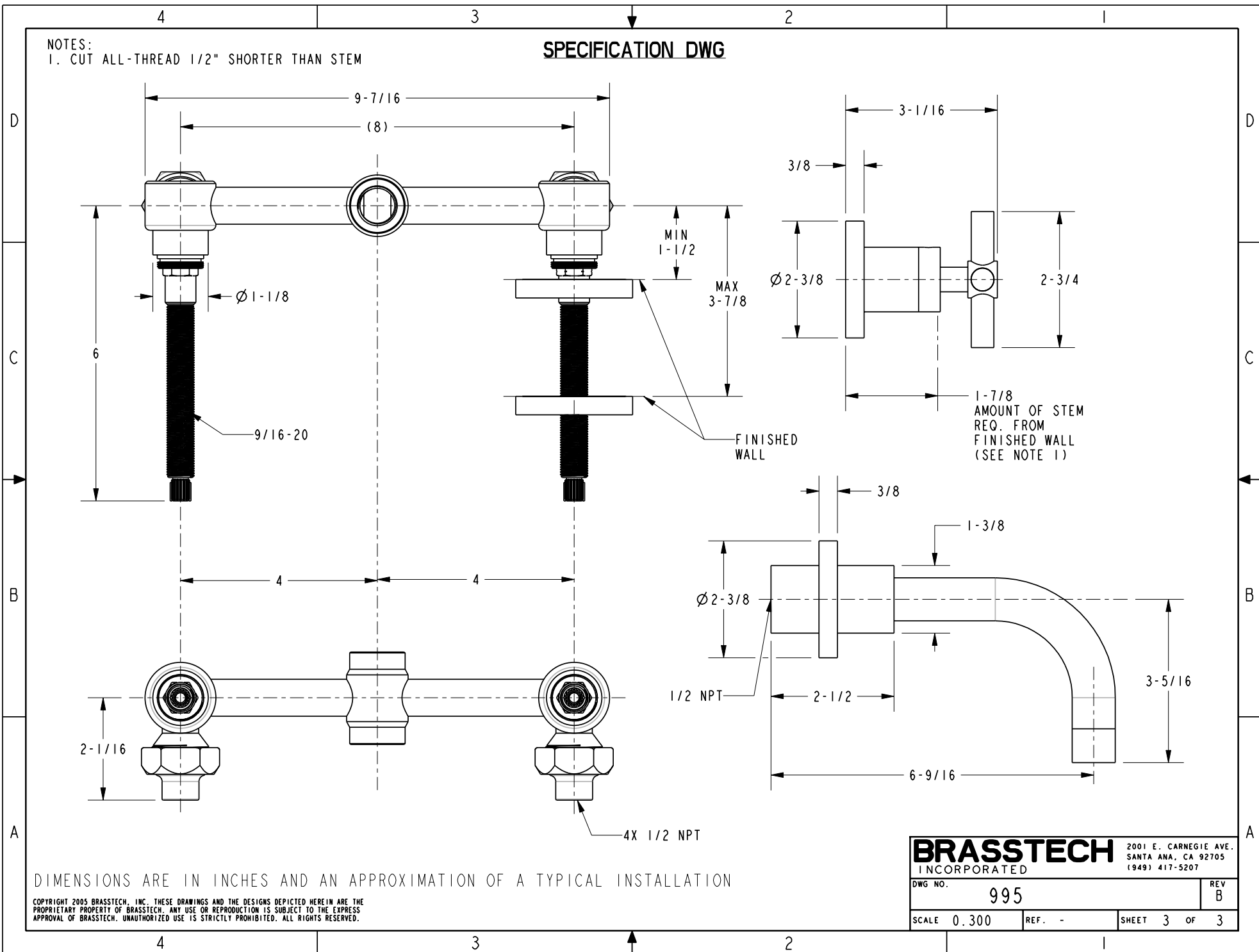

DIMENSIONS ARE IN INCHES AND AN APPROXIMATION OF A TYPICAL INSTALLATION

COPYRIGHT 2005 BRASSTECH, INC. THESE DRAWINGS AND THE DESIGNS DEPICTED HEREIN ARE THE PROPRIETARY PROPERTY OF BRASSTECH. ANY USE OR REPRODUCTION IS SUBJECT TO THE EXPRESS APPROVAL OF BRASSTECH. UNAUTHORIZED USE IS STRICTLY PROHIBITED. ALL RIGHTS RESERVED.

<b>BRASSTECH</b>		2001 E. CARNEGIE AVE.	
INCORPORATED		SANTA ANA, CA 92705	
		(949) 417-5207	
DWG NO.	995	REV	B
SCALE	0.300	REF.	-
		SHEET	3 OF 3