

NOTES:

(N1) 1. FIT / FORM / FUNCTION SHALL FOLLOW PS-E.008.

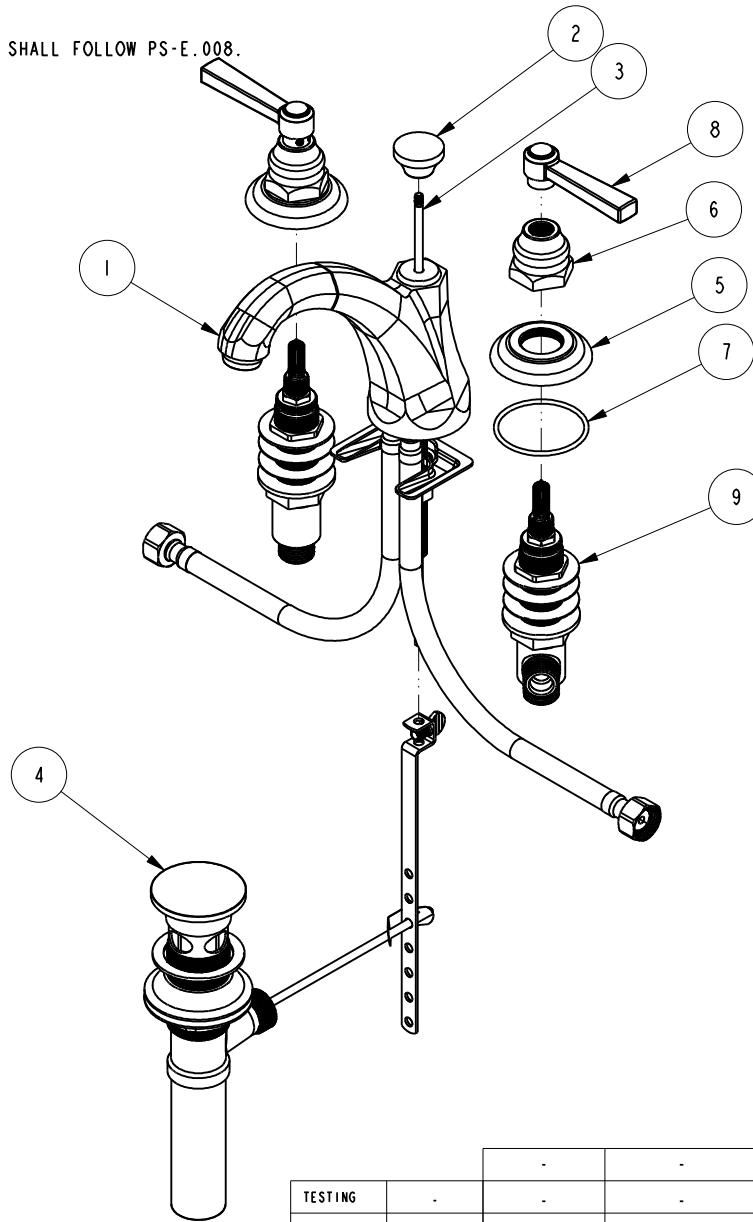

BILL OF MATERIAL (CURRENT LEVEL)

ITEM	PT/ASSY	DESCRIPTION	TYPE	QTY.
1	3-539	SPOUT ASM	ASSEMBLY	1
2	10961	SMOOTH POP - UP KNOB	PART	1
3	10288	3/16" POP UP ROD	PART	1
4	325	POP UP ASSEMBLY	ASSEMBLY	1
5	10048	ESCUTCHEON W/S VALVE	PART	2
6	10523	HEX ESCUTCHEON BONNET	PART	2
7	91231	O-RING, #2-136, EPDM, 65-75 DURO	PART	2
8	2-436	LEVER HANDLE ASM	ASSEMBLY	2
9	1-525	W/S VALVE ASM	ASSEMBLY	1

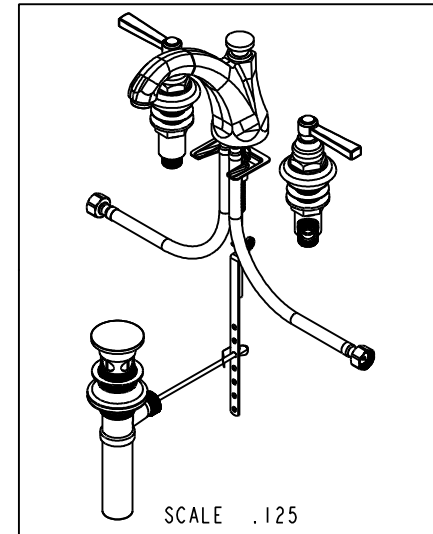

TESTING	-	-	-
ASSEMBLY	-	-	-
PLATING	-	-	-
POLISHING	-	NEXT ASSY	USED ON
MACHINING	-	APPLICATION	
TOOLING	FIXTURE #	REMOVE ALL BURRS AND SHARP EDGES	

UNITS ARE: INCHES [MM]  
 TOLERANCES ARE:  
 FRACTIONS DECIMALS ANGLES  
 $\pm 1/16"$  .X  $\pm .1$  [2,5]  $\pm 1^\circ$   
 $\pm .xx$   $\pm .06$  [1,5]  
 (X.XXX) DENOTES CRITICAL DIMS.  
 ALL THREADS ARE CRITICAL

**BRASSTECH** 2001 CARNEGIE AVE.  
 INCORPORATED SANTA ANA, CA 92705  
 (949) 417-5207

WIDESPREAD FAUCET

-	B	EN-3371	08/04/17	J.M
-	A	EN-2832	11/06/14	-
-	-	EN-2781	08/18/14	-
ZONE	REV	DESCRIPTION	DATE	APPROVED

COPYRIGHT 2005 BRASSTECH, INC.  
 THESE DRAWINGS AND THE DESIGNS  
 DEPICTED HEREIN ARE THE PROPRIETARY  
 PROPERTY OF BRASSTECH. ANY USE  
 OR REPRODUCTION IS SUBJECT TO  
 THE EXPRESS APPROVAL OF BRASSTECH.  
 UNAUTHORIZED USE IS STRICTLY  
 PROHIBITED. ALL RIGHTS RESERVED.

DRAWN VINAY 08/04/17  
 CHECKED RAVINDRA 08/04/17  
 APPROVED J.M 08/04/17

DWG NO.	910C	REV	B
SCALE	.225	REF.	-
SHEET	1	OF	2

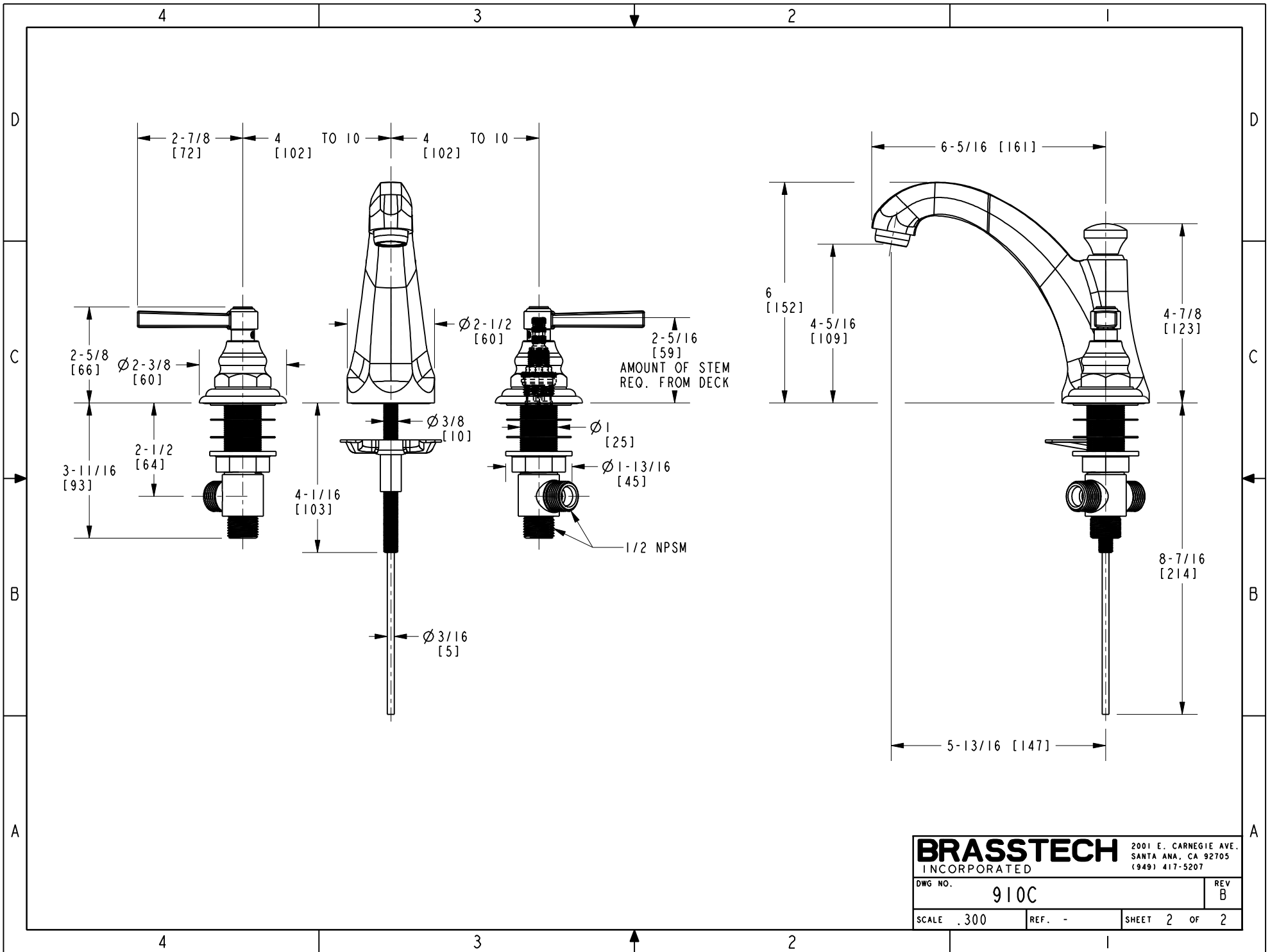

**BRASSTECH** 2001 E. CARNEGIE AVE.  
 INCORPORATED SANTA ANA, CA 92705  
 (949) 417-5207

DWG NO.	910C	REV	B
SCALE	.300	REF.	-
SHEET 2		OF 2	