

Bondi Deluxe Chair

Item#: 62775

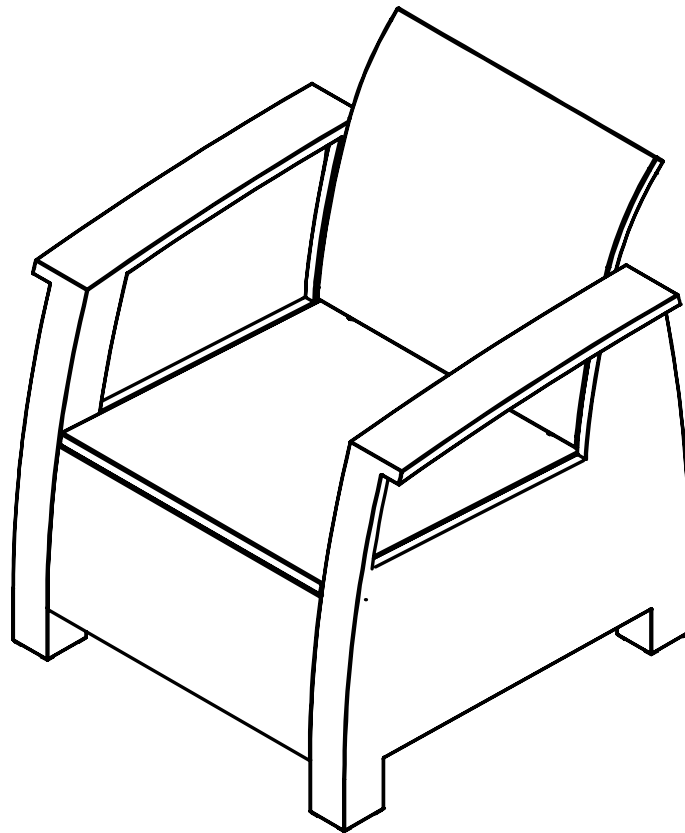

ATTACH YOUR RECEIPT HERE

Keep a copy of your proof of purchase or order confirmation which will be needed if you need to contact us about warranty coverage.

Purchase Date: _____



SAVE THESE INSTRUCTIONS FOR FUTURE REFERENCE.



Questions, problems, missing parts?

Before returning to your retailer, our exceptional customer service is available.

Call us toll-free at (866) 985-7877, email us at cservice@welltraveled.net, or go online and live chat at www.wtliving.com. Our hours are: 9 a.m. – 6 p.m., EST, Monday – Friday.



BEFORE YOU BEGIN

Before beginning assembly, make sure all parts are present. Compare parts received with the parts list. If any part is missing or damaged, do NOT attempt to assemble the product. Please read and understand this entire manual before attempting to assemble, operate or install this product. If you have any questions regarding the product, please call us toll-free at **(866) 985-7877**, email us at cservice@welltraveled.net, or go online and live chat at www.wtliving.com. Our hours are: **9 a.m. – 6 p.m., EST, Monday – Friday.**



GENERAL INFORMATION

Your new Bondi Chair is made from the finest materials available. It should provide many years of enjoyment with minimal care.

Keep your Bondi Chair clean. For best results, clean with a soft, damp cloth. If you use furniture covers always make sure the Bondi Chair is clean and completely dry before covering as mold may form in dark, wet places. Remove cushions prior to covering and store them in a dry, temperature controlled place. Check the hardware on your Bondi Chair regularly to make sure it is secure.

The weight limit is 350 lb/160 kg.



SAFETY INFORMATION

WARNING

Do not stand or allow children to stand on the assembled product. Ensure hardware is securely in place. Perform periodic checks to make sure the connections are secure and adjust if needed.

CAUTION

Read all instructions before beginning assembly. Failure to do so may result in faulty assembly and potential injury. Assemble the item on a soft, non-abrasive surface such as carpet or cardboard to avoid damaging the item.

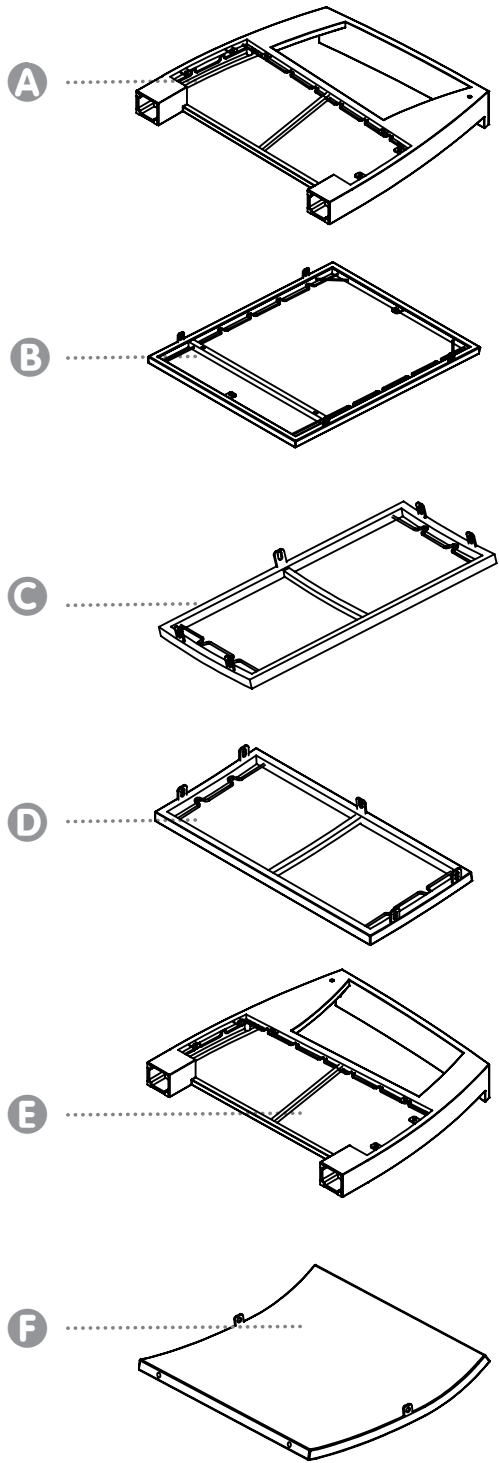

PART	DESCRIPTION	QUANTITY
A	Right Side Panel	1
B	Seat Panel	1
C	Front Base Panel	1
D	Rear Base Panel	1
E	Left Side Panel	1
F	Seat Back	1



HARDWARE CONTENTS



G
M6x20 Bolt
Qty: 16



H
M6x35 Bolt
Qty: 2



I
Washer
Qty: 18



Hex Key

Assemble in a clear area on a spacious, nonabrasive surface such as a carpet or blanket. © 2020 WTLiving.com

ASSEMBLY



1 Locate the **Right Side Panel (A)** and lay it on a flat surface with the open side facing up and the feet towards you. Place a **Washer (I)** on each of 5 **Bolts (G)**. Position the **Seat Panel (B)** on the **Right Side Panel (A)** as shown. Align the eyelets on each panel and insert a **Bolt (G)** with **Washer (I)** into each of 5 sets of eyelets and gently tighten. Position the **Front Base Panel (C)** as shown and secure to the **Right Side Panel (A)** and **Seat Panel (B)** using 3 **Bolts (G)** with **Washers (I)**.

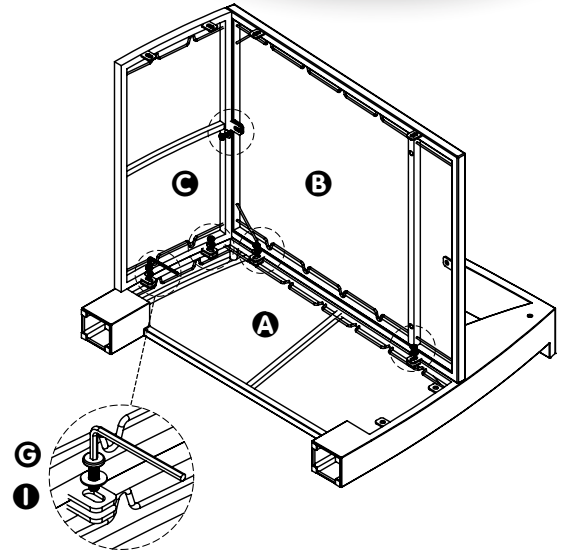

Hardware Used: **G Bolt (M6x20) x5**
I Washer x5

2 Attach the **Rear Back Panel (D)** to the **Right Side Panel (A)** and the **Seat Panel (B)**: align the eyelets on the **Rear Back Panel (D)** with the eyelets on the already joined panels as shown, then insert a **Bolt (G)** with **Washer (I)** into each of the 3 aligned sets of eyelets. Tighten using the **Hex Key** but do not over-tighten.

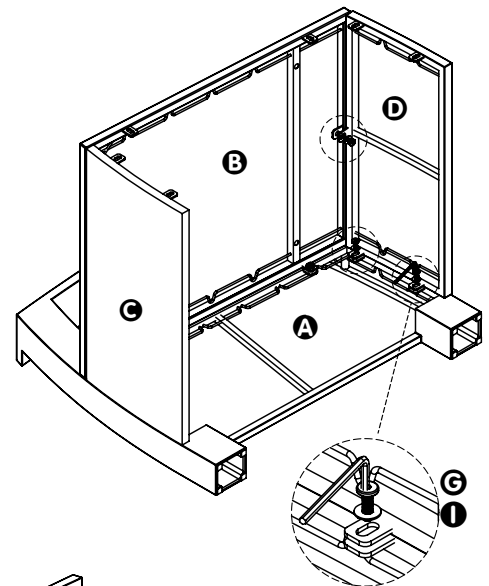

Hardware Used: **G Bolt (M6x20) x3**
I Washer x3

3 Locate the **Left Side Panel (E)** and lay it on a flat surface with the open side facing up and the feet towards you. Position the partially-assembled chair on top of the **Left Side Panel (E)** as shown. Place a **Washer (I)** on each of 6 **Bolts (G)**. Align the eyelets on each panel and insert the 6 **Bolts (G)** with **Washers (I)** into each of 6 sets of eyelets as shown.

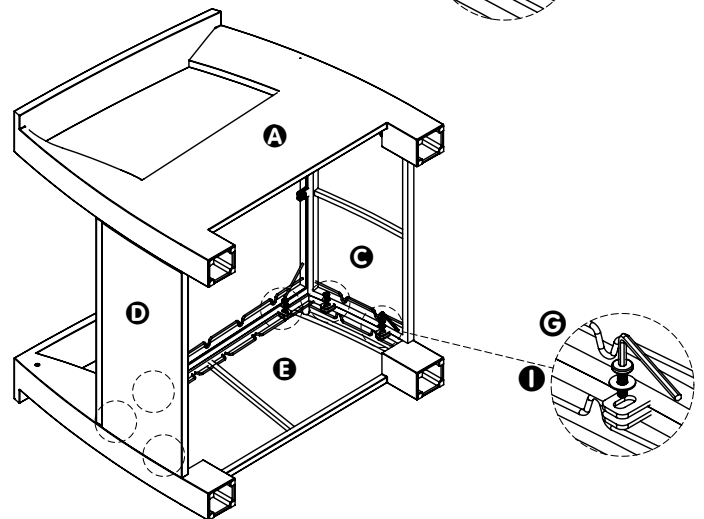

Hardware Used: **G Bolt (M6x20) x6**
I Washer x6

4 Attach the **Back Panel** **F** to both **Side Panels** by aligning the eyelets on the back of the **Back Panel** with the eyelets near the rear of the arms of the **Side Panels**. Insert a **Bolt** **G** with **Washer** **I** into each of the aligned sets of eyelets.

Attach the **Back Panel** to the **Seat Panel** by aligning the holes at the bottom of the **Back Panel** with the eyelets near the rear of the **Seat Panel**. From the underside of the **Seat Panel**, insert a **Bolt** **H** with **Washer** **I** into each of the aligned eyelets/holes.

Tighten all **Bolts** using the **Hex Key** but do not over-tighten.

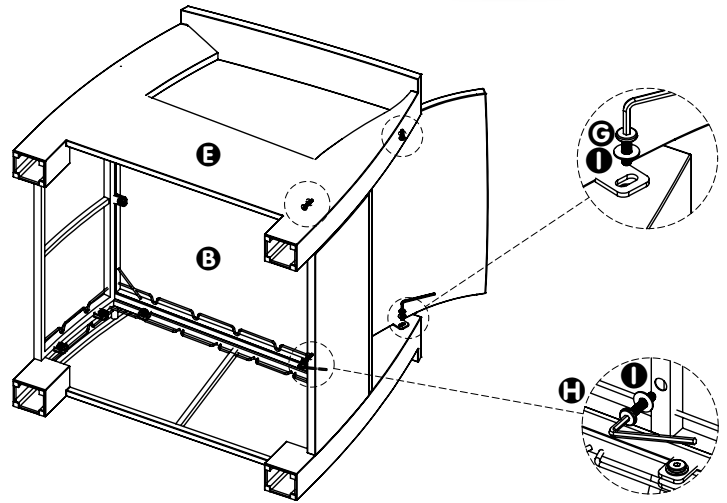

Hardware Used:

- G Bolt (M6x20) x2**
- H Bolt (M6x30) x2**
- I Washer x4**

5 **Check all hardware.** Adjust and tighten where necessary for a secure connection, but do not over-tighten.

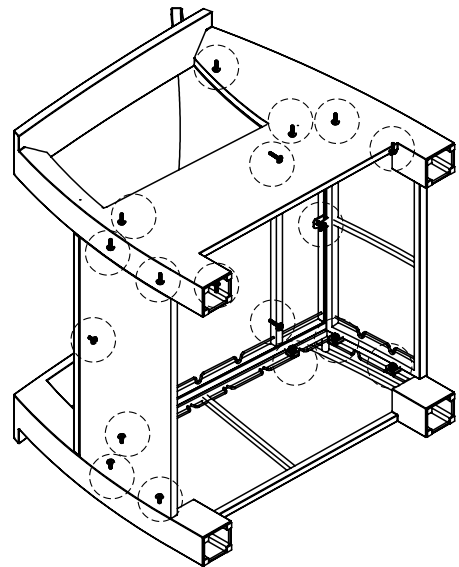

Your Bondi Chair is fully assembled!

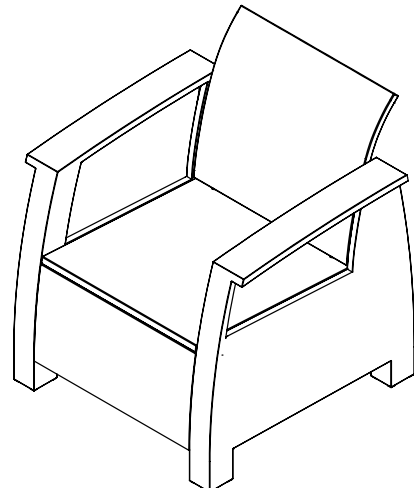



1 YEAR LIMITED WARRANTY

Customers in the Continental US

All components are warranted for a period of 1 year after date of purchase by the original owner against defects in materials and workmanship under normal use. This warranty does not cover normal wear and weathering, assembly and or maintenance or use in a commercial application if model is not designated as a commercial model. At Well Traveled Living's sole discretion products under warranty will be repaired and or replaced at no charge to the customer. In returns sent back to Well Traveled Living must be sent via prepaid freight and in the original retail packaging.

For warranty service contact Well Traveled Living at the address, phone numbers or internet site and email listed in this owner's manual. Be sure to have your sales receipt, date of purchase and catalogue/model numbers available when calling. All warranty service will be coordinated by the Well Traveled Living's Amelia Island, Florida service center.

This warranty is extended only to the original purchaser. Proof of purchase will be required before warranty service is rendered. The sales receipt is the only valid proof of purchase. This warranty only covers failures due to defects in materials or workmanship which occur during normal use. Failures and/or damage which result from accident, negligence, misuse, abuse, neglect, mishandling, alteration, or modification, failure to maintain, improper assembly or maintenance, service by unauthorized agency, use of unauthorized components, or damage that is attributable to acts of God are NOT covered.

THIS LIMITED WARRANTY GIVES YOU SPECIFIC LEGAL RIGHTS AND YOU MAY ALSO HAVE OTHER RIGHTS WHICH VARY FROM JURISDICTION TO JURISDICTION. THE PROVISIONS OF THE UNITED NATIONS CONVENTION ON CONTRACTS FOR THE SALES OF GOODS SHALL NOT APPLY TO THIS LIMITED WARRANTY OR THE SALE OF PRODUCTS COVERED BY THIS LIMITED WARRANTY.

- THERE ARE NO EXPRESS WARRANTIES EXCEPT AS LISTED ABOVE
- PURCHASER ASSUMES ALL RISKS IN THE ASSEMBLY AND OPERATION OF THIS UNIT
- FAILURE TO FOLLOW WARNINGS AND OPERATIONAL INSTRUCTIONS CONTAINED IN THIS MANUAL CAN RESULT IN SEVERE PROPERTY DAMAGE AND/OR PERSONAL INJURY
- IN NO EVENT WILL WELL TRAVELED LIVING, OR ITS DIRECTORS, OFFICERS OR AGENTS BE LIABLE TO THE PURCHASER OR ANY THIRD PARTY, WHETHER IN CONTRACT, IN TORT, OR ON ANY OTHER BASIS, FOR ANY INDIRECT, SPECIAL, PUNITIVE, EXEMPLARY, CONSEQUENTIAL, OR INCIDENTAL LOSS, COST, OR DAMAGE ARISING OUT OF OR IN CONNECTION WITH THE SALE, MAINTENANCE, USE, OR INABILITY TO USE THE PRODUCT, EVEN IF WELL TRAVELED LIVING OR ITS DIRECTORS, OFFICERS OR AGENTS HAVE BEEN ADVISED OF THE POSSIBILITY OF SUCH LOSSES, COSTS OR DAMAGES, OR IF SUCH LOSSES, COSTS, OR DAMAGES ARE FORESEEABLE. IN NO EVENT WILL WELL TRAVELED LIVING, OR ITS OFFICERS, DIRECTORS, OR AGENTS BE LIABLE FOR ANY DIRECT LOSSES, COSTS OR DAMAGES THAT EXCEED THE PURCHASE PRICE OF THE PRODUCT.
- SOME JURISDICTIONS DO NOT ALLOW THE EXCLUSION OR LIMITATION OF INCIDENTAL OR CONSEQUENTIAL DAMAGES, SO THE ABOVE LIMITATION OR EXCLUSION MAY NOT APPLY TO THE PURCHASER.



Important Notice

Do NOT return to place of purchase—for customer service and warranty issues contact our customer service center at (866) 985-7877, email us at cservice@welltraveled.net, or go online and live chat at www.wtliving.com. Our hours are: 9 a.m. – 6 p.m., EST, Monday – Friday.



Distributed By:
Well Traveled Living

716 S 8th Street, Amelia Island, FL 32034
wtliving.com | cservice@welltraveled.net
(866) 985-7877