

The Luxury of Outdoor Living

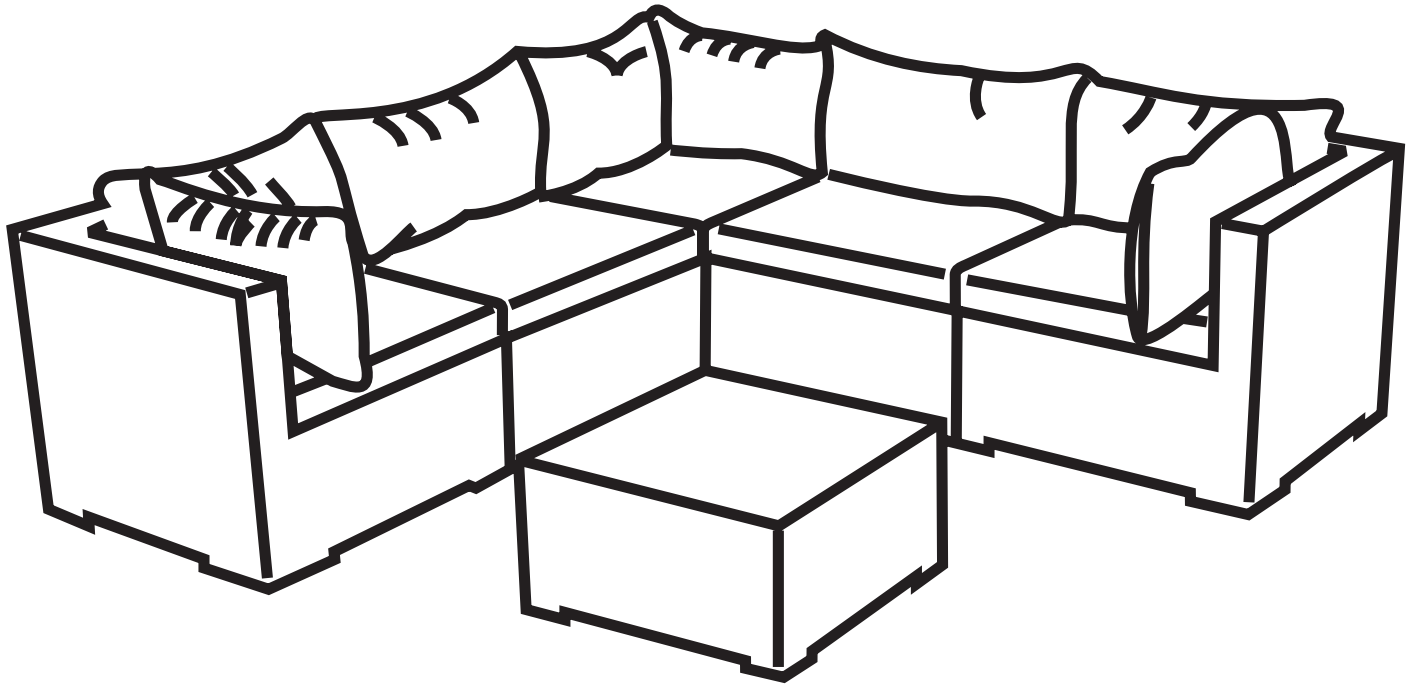

SINO SOFA SET Item#: 62173



ATTACH YOUR RECEIPT HERE

Keep a copy of your proof of purchase or order confirmation which will be needed if you need to contact us about warranty coverage.

Purchase Date: _____



SAVE THESE INSTRUCTIONS FOR FUTURE REFERENCE.



Questions, problems, missing parts?

Before returning to your retailer, our exceptional customer service is available.

Call us toll-free at **(866) 985-7877**, email us at **cservice@welltraveled.net**, or go online and live chat at **www.wtliving.com**. Our hours are: **9 a.m. – 6 p.m., EST, Monday – Friday**

Manual updated Jan 2019



BEFORE YOU BEGIN

Before beginning assembly, make sure all parts are present. Compare parts received with the “Parts List.” If any part is missing or damaged, do NOT attempt to assemble the product. Please read and understand this entire manual before attempting to assemble, operate or install this product. If you have any questions regarding the product, please call us toll-free at **(866) 985-7877**, email us at cservice@welltraveled.net, or go online and live chat at www.wtliving.com. Our hours are: **9 a.m. – 6 p.m., EST, Monday – Friday.**



GENERAL INFORMATION

Your new sofa set is made from the finest materials available. It should provide many years of enjoyment with minimal care.

Keep your sofa set clean. For best results, clean with a soft, damp cloth. If you use furniture covers, always make sure the sofa set is clean and completely dry before covering, as mold may form in dark, wet places. Remove cushions prior to covering and store them in a dry, temperature controlled place. Check the connectors on your sofa set regularly to make sure it is secure.

The weight limit per seat of the sofa set is 220 lbs.



SAFETY INFORMATION

WARNING

DO NOT stand or allow children to stand on the assembled product. Make sure connectors are securely in place. Perform periodic checks to make sure the connectors are secure and adjust if needed.

CAUTION

READ all instructions before beginning assembly. Failure to do so may result in faulty assembly and potential injury. Assemble the item on a soft, non-abrasive surface such as carpet or cardboard to avoid damaging the item.

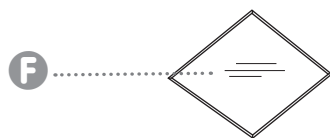
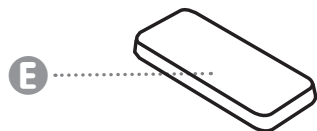
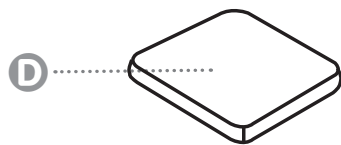
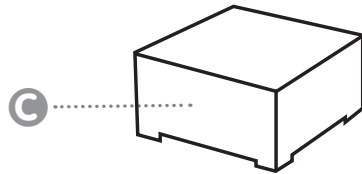
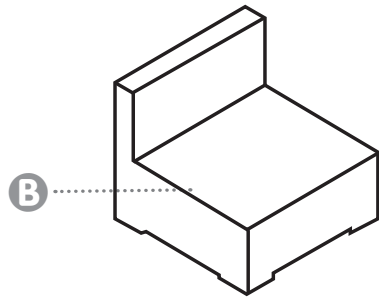
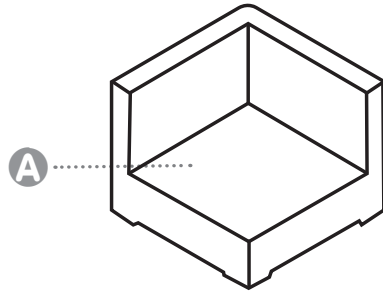

PART	DESCRIPTION	QUANTITY
A	Corner Seat	3
B	Middle Seat	2
C	Table	1
D	Seat Cushion	5
E	Back Cushion	8
F	Glass Tabletop	1



HARDWARE CONTENTS



G

Connector
Qty: 4

1 Connect **Corner Seat A** to **Middle Seat B** using 1 **Connector G**.

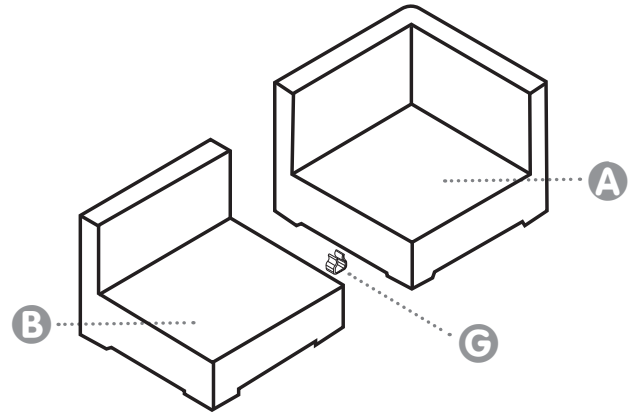

2 Connect another **Corner Seat A** to the opposite side of the **Middle Seat B** using 1 **Connector G**.

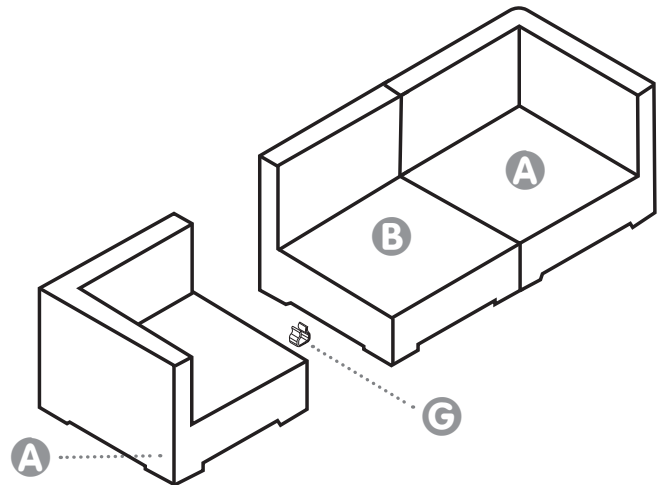

3 Then connect another **Middle Seat B** to the opposite side of the **Corner Seat A** using 1 **Connector G**.

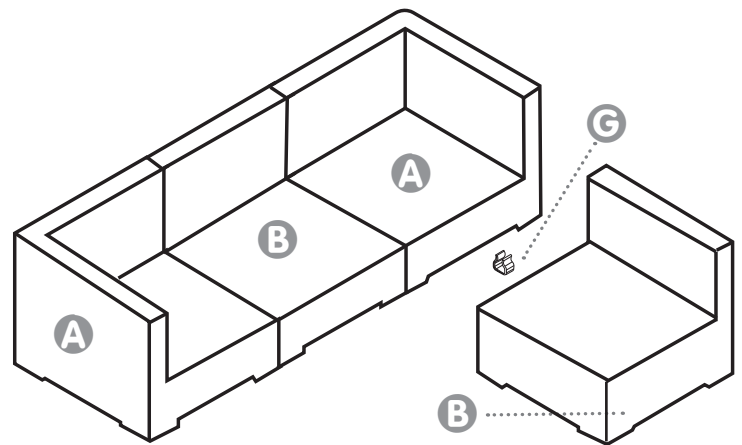

4 Connect other **Corner Seat A** to the side of the **Middle Seat B** using 1 **Connector G**.

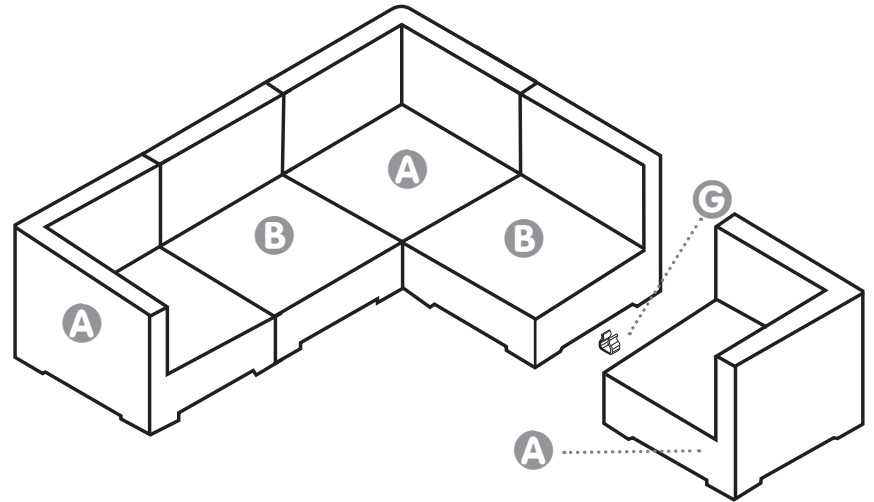

5 Place the **Seat Cushions D** and **Back Cushions E** onto assembled sofa set and place **Table C** as desired with set. Carefully place the **Glass Tabletop F** on the **Table**.

Enjoy your new Sino Sofa Set!

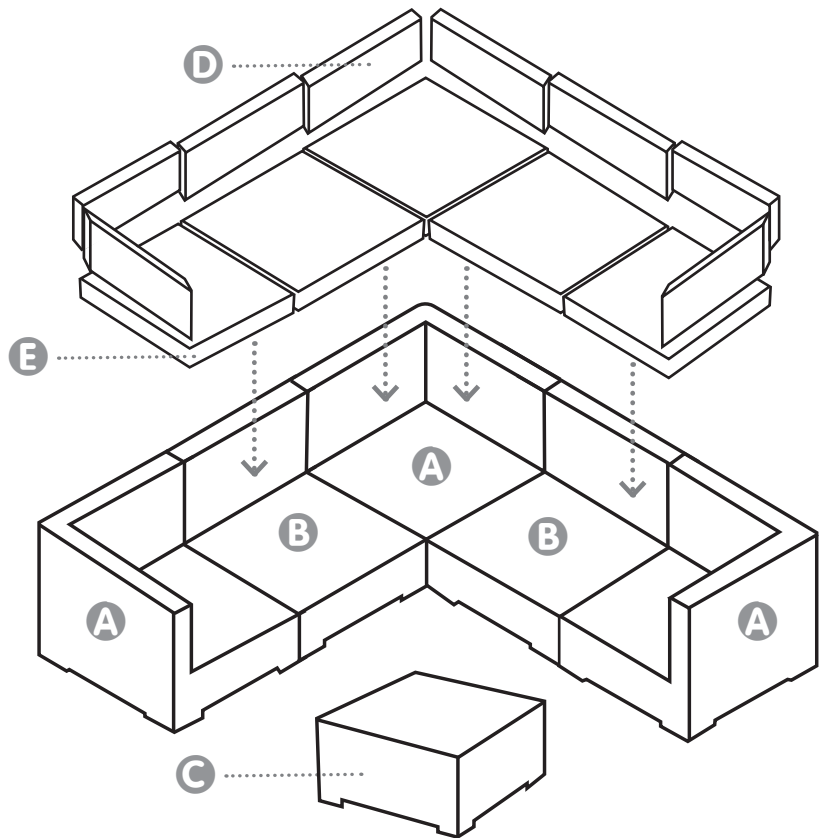



1 YEAR LIMITED WARRANTY

Customers in the Continental US

All components are warranted for a period of 1 year after date of purchase by the original owner against defects in materials and workmanship under normal use. This warranty does NOT cover normal wear and weathering, assembly and/or maintenance OR use in a commercial application if model is not designated as a commercial model. At Well Traveled Living's sole discretion, products under warranty will be repaired and/or replaced at no charge to the customer. Any returns sent back to Well Traveled Living must be sent via prepaid freight and in the original retail packaging.

For warranty service contact Well Traveled Living at the address, phone numbers or internet site and email listed in this owner's manual. Be sure to have your sales receipt, date of purchase and catalogue/model numbers available when calling. All warranty service will be coordinated by the Well Traveled Living's, Amelia Island, Florida service center.

This warranty is extended only to the original purchaser. Proof of purchase will be required before warranty service is rendered. The sales receipt is the only valid proof of purchase. This warranty only covers failures due to defects in materials or workmanship which occur during normal use. Failures and/or damage which result from accident, negligence, misuse, abuse, neglect, mishandling, alteration or modification, failure to maintain, improper assembly or maintenance, service by unauthorized agency or use of unauthorized components or damage that is attributable to acts of God are NOT covered.

This limited warranty gives you specific legal rights and you may also have other rights which vary from jurisdiction to jurisdiction. The provisions of the United Nations Convention on Contracts for the Sales of Goods shall not apply to this limited warranty or the sale of products covered by this limited warranty.

- THERE ARE NO EXPRESS WARRANTIES EXCEPT AS LISTED ABOVE
- PURCHASER ASSUMES ALL RISKS IN THE ASSEMBLY AND OPERATION OF THIS UNIT
- FAILURE TO FOLLOW WARNINGS AND OPERATIONAL INSTRUCTIONS CONTAINED IN THIS MANUAL CAN RESULT IN SEVERE PROPERTY DAMAGE AND/OR PERSONAL INJURY
- IN NO EVENT WILL WELL TRAVELED LIVING, OR ITS DIRECTORS, OFFICERS OR AGENTS BE LIABLE TO THE PURCHASER OR ANY THIRD PARTY, WHETHER IN CONTRACT, IN TORT, OR ON ANY OTHER BASIS, FOR ANY INDIRECT, SPECIAL, PUNITIVE, EXEMPLARY, CONSEQUENTIAL, OR INCIDENTAL LOSS, COST, OR DAMAGE ARISING OUT OF OR IN CONNECTION WITH THE SALE, MAINTENANCE, USE, OR INABILITY TO USE THE PRODUCT, EVEN IF WELL TRAVELED LIVING OR ITS DIRECTORS, OFFICERS OR AGENTS HAVE BEEN ADVISED OF THE POSSIBILITY OF SUCH LOSSES, COSTS OR DAMAGES, OR IF SUCH LOSSES, COSTS, OR DAMAGES ARE FORESEEABLE. IN NO EVENT WILL WELL TRAVELED LIVING, OR ITS OFFICERS, DIRECTORS, OR AGENTS BE LIABLE FOR ANY DIRECT LOSSES, COSTS OR DAMAGES THAT EXCEED THE PURCHASE PRICE OF THE PRODUCT.
- SOME JURISDICTIONS DO NOT ALLOW THE EXCLUSION OR LIMITATION OF INCIDENTAL OR CONSEQUENTIAL DAMAGES, SO THE ABOVE LIMITATION OR EXCLUSION MAY NOT APPLY TO THE PURCHASER.



Important Notice

Do NOT return to place of purchase—for customer service and warranty issues contact our Customer Service Center at: (866) 985-7877, email us at cservice@welltraveled.net, or go online and live chat at www.wtliving.com. Our hours are: 9 a.m. – 6 p.m., EST, Monday – Friday



Distributed By:
Well Traveled Living
716 S 8th Street, Amelia Island, FL 32034
wtliving.com | cservice@welltraveled.net
(866) 985-7877