

Comfort, Quality & Style Since 1998

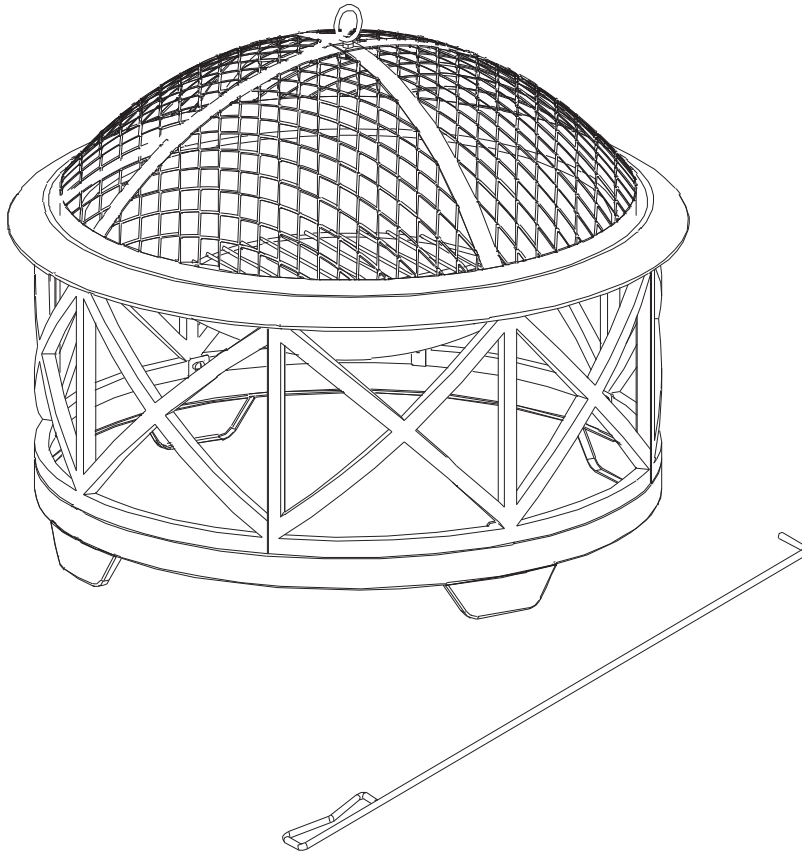

## Portsmouth 30 in. Wood Burning Fire Pit

Item#: 60904



### **WARNING** FOR YOUR SAFETY

1. Improper installation, adjustment, alteration, service or maintenance can cause injury or property damage.
2. Read the installation, operation, and maintenance instructions thoroughly before installing or servicing this equipment.
3. Failure to follow these instructions could result in fire or explosion, which could cause property damage, personal injury, or death.

 **WARNING**  
For Outdoor Use Only

 **WARNING**  
This product can expose you to chemicals including Carbon Monoxide, Di(2-ethylhexyl)phthalate (DEHP) and Diisononyl phthalate (DINP), which are known to the State of California to cause cancer and birth defects or other reproductive harm. For more information, go to [www.P65Warnings.ca.gov](http://www.P65Warnings.ca.gov).



### **ATTACH YOUR RECEIPT HERE**

Keep a copy of your proof of purchase or order confirmation which will be needed if you need to contact us about warranty coverage.

Purchase Date: \_\_\_\_\_



### **Questions, problems, missing parts?**

Before returning to your retailer, our exceptional customer service is available.

Call us toll-free at (866) 985-7877 9 a.m. – 6 p.m., EST, Monday – Friday, email us at [cservice@welltraveled.net](mailto:cservice@welltraveled.net), or go online and live chat at [www.wtliving.com](http://www.wtliving.com).



## TABLE OF CONTENTS

Table of Contents	Page 2
Before You Begin	Page 2
Package Contents	Page 3
Safety Information	Page 4
Assembly	Page 5-6
Care and Maintenance	Page 7
Warranty Information	Page 8



### BEFORE YOU BEGIN

Please read and understand this entire manual before attempting to assemble, operate or install this appliance. If you have any questions regarding the product, please call us toll-free at **(866) 985-7877 9 a.m. – 6 p.m., EST, Monday – Friday**, email us at [cservice@welltraveled.net](mailto:cservice@welltraveled.net), or go online and live chat at [www.wtliving.com](http://www.wtliving.com).

This manual contains important information about the assembly, operation and maintenance of this patio fire pit. General safety information is presented in the first few pages and is also located throughout this manual. Keep this manual for future reference and to educate new users of this appliance.

# PACKAGE CONTENTS

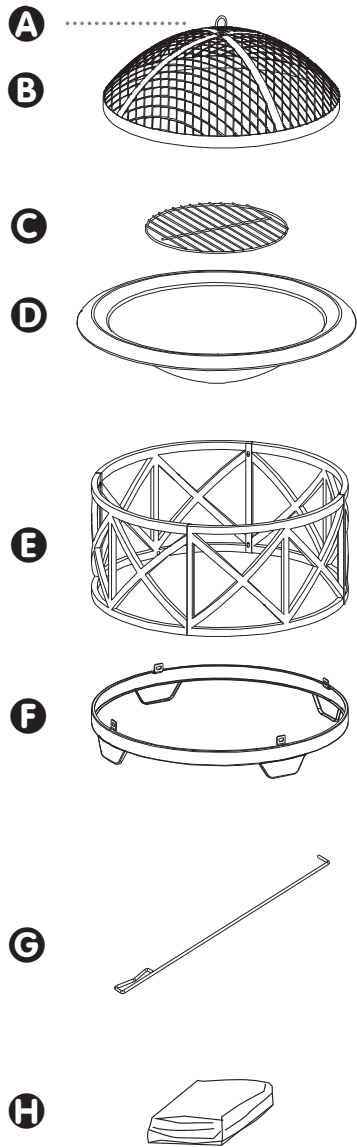

PART	DESCRIPTION	QUANTITY
<b>A</b>	Fire Screen Handle	1
<b>B</b>	Fire Screen	1
<b>C</b>	Wood Grate	1
<b>D</b>	Fire Bowl	1
<b>E</b>	Side Panel	4
<b>F</b>	Base	1
<b>G</b>	Fire Tool	1
<b>H</b>	Protective Cover	1



## HARDWARE CONTENTS



**I**  
M6 Nut  
Qty: 1



**J**  
M6x15 Screw  
Qty: 12



## **WARNING** **FOR YOUR SAFETY**

1. This appliance is for outdoor use only, and shall NOT be used in a building, garage or any other enclosed area.
2. Do NOT use this fire pit for indoor heating. TOXIC carbon monoxide fumes can accumulate and cause asphyxiation.
3. This fire pit is NOT for commercial use.
4. This fire pit is NOT to be operated by children.
5. This fire pit is NOT to be used in or on boats or recreational vehicles.
6. Always use in accordance with all applicable local, state and national codes. Contact your local fire department for details on outdoor burning.
7. When using this fire pit, exercise the same precautions you would with any open fire.
8. The use of alcohol, prescription or non-prescription drugs may impair the consumer's ability to properly assemble or safely operate this fire pit.
9. Do NOT use this fire pit without reading the entire "Owner's Manual".
10. This fire pit is for use with dry, seasonal hardwood. It will burn hotter, more completely and create less smoke.
11. Do NOT burn charcoal briquets, lump charcoal, manufactured logs, driftwood, trash, leaves, paper, cardboard, plywood, painted or stained or pressure treated wood. Avoid using softwoods such as pine or cedar that can throw sparks.
12. Do NOT alter this fire pit in any manner.
13. Do NOT use this fire pit until it is COMPLETELY assembled and all parts are securely fastened and tightened.
14. Do NOT store or use gasoline or other flammable vapors or liquids in the vicinity of this or any other appliance.
15. Do NOT store or use an LP gas cylinder within 10 feet (3.05m) of this fire pit while it is in operation.
16. Do NOT use this fire pit near automobiles, trucks, vans or recreational vehicles.
17. Do NOT use in an explosive atmosphere. Keep outdoor area clean and free from combustible materials, gasoline and other flammable liquids.
18. Do NOT use this fire pit under any overhead or near any unprotected combustible constructions. Avoid using near or under overhanging trees and shrubs.
19. Always use this fire pit on a hard, level non-combustible surface such as concrete, rock or stone. An asphalt or blacktop surface may not be acceptable for this purpose. Do NOT use on wooden decks.
20. Always empty this fire pit before each use.
21. Do NOT wear flammable or loose clothing when operating this fire pit.
22. Do NOT use in windy conditions.
23. Do NOT use this fire pit unless fire screen is securely in place.
24. Do NOT use gasoline, kerosene, diesel fuel, lighter fluid or alcohol to light or relight fires.
25. Keep all electrical cords away from a hot fire pit.
26. All surfaces of this fire pit are hot when in operation. To avoid burns, do NOT touch fire pit until it has completely cooled unless you are wearing protective gear (Potholders, gloves, BBQ mittens, hot pads & etc.). Never touch ashes or coals to see if they are hot.
27. Do NOT leave a lit fire pit unattended, especially around children and pets.
28. Do NOT attempt to move or store this fire pit until all ashes and coals are completely extinguished.
29. Do NOT remove ashes or coals until they are completely and fully extinguished.
30. Use heat-resistant gloves or hot pads when contacting handles.
31. Use long, sturdy fire pit tools when adding or moving logs.
32. Do NOT overload the fire pit. Do not add additional firewood until the fire burns down. NOTICE: If any portion of the bowl lid or spark guards of this fire pit are glowing red it is overloaded.
33. Do NOT lean over this fire pit when lighting or when in use.
34. Do NOT place a hot fire screen or hot fire pit tools onto combustible surfaces such as grass, wooden deck or furniture.
35. Avoid breathing smoke from the fire and avoid getting it into your eyes.
36. This fire pit should be thoroughly inspected and cleaned on a regular basis.
37. After a period of storage and/or non-use, check for signs of damage and creosote build-up. Do NOT operate until necessary repairs and/or cleanup are executed.
38. Deaths, serious injury or damage to property may occur if the above is not followed exactly.

**CAUTION:** It is not recommended to use this fire pit (fire place) on a wooden or other combustible surface or any surface that is not entirely resistant to high heat. However, if you intend to use this item on a wooden deck other combustible surface or any surface that is not entirely resistant to high heat, you must use a non-flammable and heat resistant material such as concrete pavers, brick or stone between the fire pit (fire place) and the surface



## PREPARATION

Before beginning assembly, be sure to empty contents of carton and make sure all parts are present. If any parts are missing, please contact Customer Service at (866)-985-7877, Monday-Friday, 9 a.m. - 6 p.m. EST or email at [cservice@welltraveled.net](mailto:cservice@welltraveled.net).

Place all parts on a soft, level surface for assembly. No tools required for assembly.  
 Estimated Assembly Time: 15 Minutes | DO NOT over tighten hardware!

- 1 Attach **Fire Screen Handle A** to **Fire Screen B** with a **Nut I**. Securely tighten.

Hardware Used: **I** M6 Nut x1

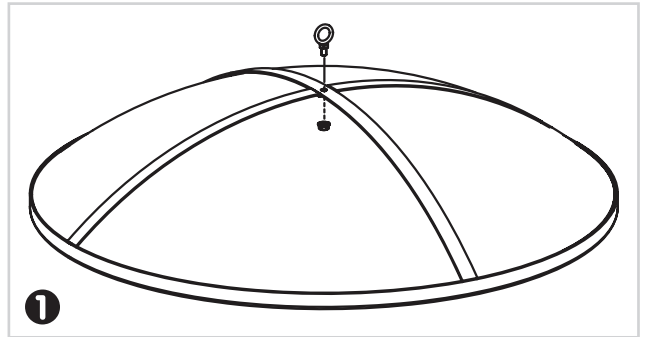

- 2 Connect 2 of the **Side Panels E** using 2 **Screws J** as shown. Connect the remaining **Side Panels** in the same manner, connecting the 4th **Side Panel** back to the first to form a complete circle.

Hardware Used: **J** M6x15 Screw x8

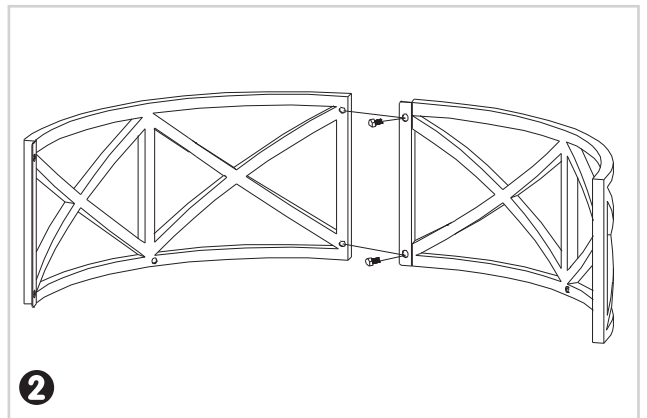

- 3 Set the assembled **Side Panels E** on top of **Base F**. (*NOTE: the drilled holes at the middle of each Side Panel should be at the bottom.*) Align the tabs at the top of the **Base** with the holes at the middle of each **Side Panel**. Connect the two pieces using 4 **Screws J**.

Hardware Used: **J** M6x15 Screw x4

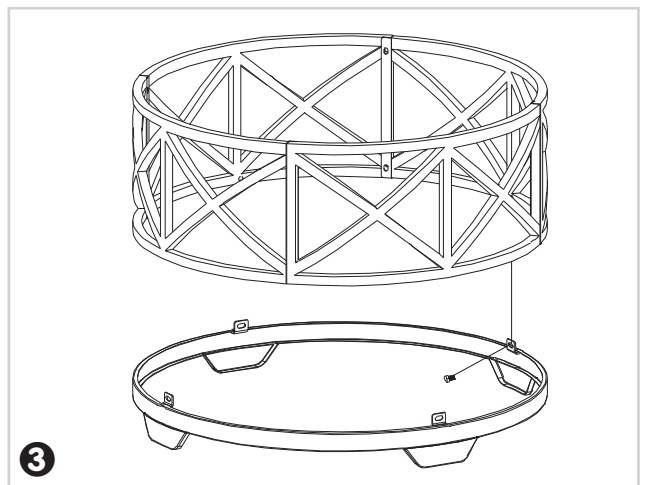

4 Lower the Fire Bowl D into the assembled Base, then place Wood Grate C in the Fire Bowl. Place Fire Screen B over the Fire Bowl.

When not in use or after use, when the fire pit is cool and has been emptied of ash, cover the fire pit with the included Vinyl Cover H.

Your Fire Pit is ready to enjoy!

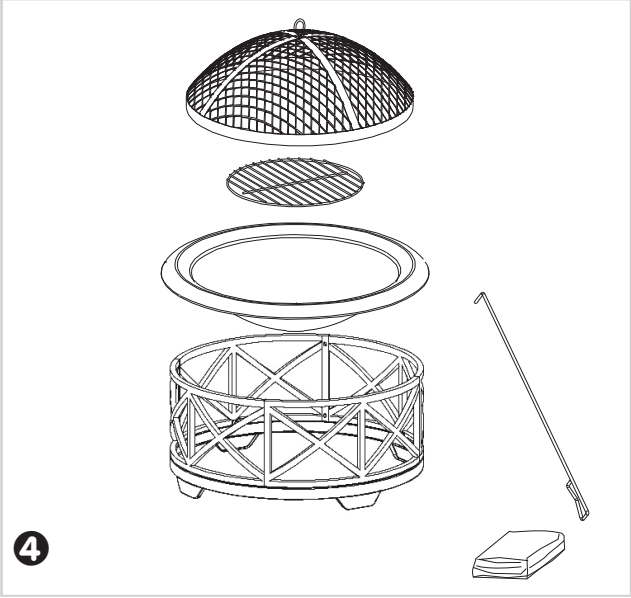



### INSPECTING:

This outdoor fire pit should be inspected on a regular basis to ensure product safety and longer product life.

**Do NOT attempt to inspect this outdoor fire pit until the fire is COMPLETELY out and fire pit is COOLED COMPLETELY.**

1. Check handle on Spark Guard/Fire Screen to make sure it is secure.
2. Check all parts for signs of damage or rust.
3. If you find any damaged parts, do NOT operate until repairs and/or replacement has been done.

### CLEANING:

This outdoor fire pit should be cleaned on a regular basis to promote a safer experience and longer product life. *NOTE: After repeated use, a slight discoloration of the finish may occur.*

**Do NOT attempt to clean this outdoor fire pit until the fire is COMPLETELY out and the fire pit has cooled completely.**

**Do NOT use oven cleaner or abrasive cleaners as they will damage this product.**

**Do NOT clean any part of this outdoor fire pit in a self cleaning oven as it may damage the finish.**

1. Wipe exterior surfaces with a mild dishwashing detergent or baking soda.
2. For stubborn surfaces, use a citrus based degreaser and a nylon scrubbing brush.
3. Rinse with clean water.
4. Remove built-up creosote from components with a chimney cleaning product.

### STORAGE:

**Do NOT move or store this outdoor fire pit until the fire is COMPLETELY out and the fire pit has cooled COMPLETELY.**

1. Once the fire is out, coals are cold and outdoor fire pit is cool to the touch, remove ashes and dispose of properly.
2. It is best to cover the outdoor fire pit with a protective vinyl cover.
3. Store assembled in a location away from children and pets.

**NOTE:** If you do not use a protective cover for your fire pit, then store this outdoor fire pit in a dry location to maximize product life.

**Fire Sense®** products are made to resist premature rusting. However, eventually, all metals will rust. Some environments promote premature rusting of metals. For best results, at the first sign of rust or other corrosion, use an emery cloth, metal-grade sand paper or a rotary tool to buff away the blemish and touch up the spot with rust-resistant spray paint available at local hardware stores.



## 1 YEAR LIMITED WARRANTY

### Customers in the Contiguous US

All components are warranted for a period of 1 year after date of purchase by the original owner against defects in materials and workmanship under normal use. This warranty does NOT cover normal wear and weathering, assembly and/or maintenance OR use in a commercial application if model is not designated as a commercial model. At Well Traveled Living's sole discretion, products under warranty will be repaired and/or replaced at no charge to the customer. Any returns sent back to Well Traveled Living must be sent via prepaid freight and in the original retail packaging.

For warranty service contact Well Traveled Living at the address, phone numbers or internet site and email listed in this owner's manual. Be sure to have your sales receipt, date of purchase and catalogue/model numbers available when calling. All warranty service will be coordinated by the Well Traveled Living's, Amelia Island, Florida service center.

This warranty is extended only to the original purchaser. Proof of purchase will be required before warranty service is rendered. The sales receipt is the only valid proof of purchase. This warranty only covers failures due to defects in materials or workmanship which occur during normal use. Failures and/or damage which result from accident, negligence, misuse, abuse, neglect, mishandling, alteration or modification, failure to maintain, improper assembly or maintenance, service by unauthorized agency or use of unauthorized components or damage that is attributable to acts of God are NOT covered.

This limited warranty gives you specific legal rights and you may also have other rights which vary from jurisdiction to jurisdiction. The provisions of the United Nations Convention on Contracts for the Sales of Goods shall not apply to this limited warranty or the sale of products covered by this limited warranty.

- THERE ARE NO EXPRESS WARRANTIES EXCEPT AS LISTED ABOVE
- PURCHASER ASSUMES ALL RISKS IN THE ASSEMBLY AND OPERATION OF THIS UNIT
- FAILURE TO FOLLOW WARNINGS AND OPERATIONAL INSTRUCTIONS CONTAINED IN THIS MANUAL CAN RESULT IN SEVERE PROPERTY DAMAGE AND/OR PERSONAL INJURY
- IN NO EVENT WILL WELL TRAVELED LIVING, OR ITS DIRECTORS, OFFICERS OR AGENTS BE LIABLE TO THE PURCHASER OR ANY THIRD PARTY, WHETHER IN CONTRACT, IN TORT, OR ON ANY OTHER BASIS, FOR ANY INDIRECT, SPECIAL, PUNITIVE, EXEMPLARY, CONSEQUENTIAL, OR INCIDENTAL LOSS, COST, OR DAMAGE ARISING OUT OF OR IN CONNECTION WITH THE SALE, MAINTENANCE, USE, OR INABILITY TO USE THE PRODUCT, EVEN IF WELL TRAVELED LIVING OR ITS DIRECTORS, OFFICERS OR AGENTS HAVE BEEN ADVISED OF THE POSSIBILITY OF SUCH LOSSES, COSTS OR DAMAGES, OR IF SUCH LOSSES, COSTS, OR DAMAGES ARE FORESEEABLE. IN NO EVENT WILL WELL TRAVELED LIVING, OR ITS OFFICERS, DIRECTORS, OR AGENTS BE LIABLE FOR ANY DIRECT LOSSES, COSTS OR DAMAGES THAT EXCEED THE PURCHASE PRICE OF THE PRODUCT.
- SOME JURISDICTIONS DO NOT ALLOW THE EXCLUSION OR LIMITATION OF INCIDENTAL OR CONSEQUENTIAL DAMAGES, SO THE ABOVE LIMITATION OR EXCLUSION MAY NOT APPLY TO THE PURCHASER.



### Important Notice

Do NOT return to place of purchase—for customer service and warranty issues contact our Customer Service Center at: **(866) 985-7877 9 a.m. – 6 p.m., EST, Monday – Friday**, email us at [cservice@welltraveled.net](mailto:cservice@welltraveled.net), or go online and live chat at [www.wtliving.com](http://www.wtliving.com).



Distributed By:  
Well Traveled Living  
716 S 8th Street, Amelia Island, FL 32034  
[wtliving.com](http://wtliving.com) | [cservice@welltraveled.net](mailto:cservice@welltraveled.net)  
(866) 985-7877