

Signature +

Model # 5808

Signature Plus Mail Post



DESCRIPTION

Timeless Style Infused in History...These classic lines were created with impeccable style and craftsmanship for lasting appeal.

- Weather resistant, low maintenance material
- Installs easily over a standard 4x4 wood post
- Recommended for mailboxes up to 12lbs
- 100% high-grade polyethylene with built in UV inhibitors
- Warranty: 15-Yr Residential Use / 5-Yr Commercial Use

PRODUCT DIMENSIONS

Outside Dimensions: 40.4in L x 8in W x 56.5in H (102.5cm x 20.3cm x 143.5cm)

Paper Holder Inset Dimensions: 10.5in W x 3.5in H (26.6cm x 8.8cm)

Paper Holder Inside Dimensions: 12in L x 5.5in W x 4.5in H (30.5cm x 14cm x 11.4cm)

Wall Thickness: 0.125in (3.17mm)

Part Weight: 15lbs (6.8kg)

Material: Polyethylene

Contents: Post, Paper Holder Arm, Planter Arm, and Hardware

Note: 4x4 wood post, mailbox, and mailbox mounting hardware NOT included

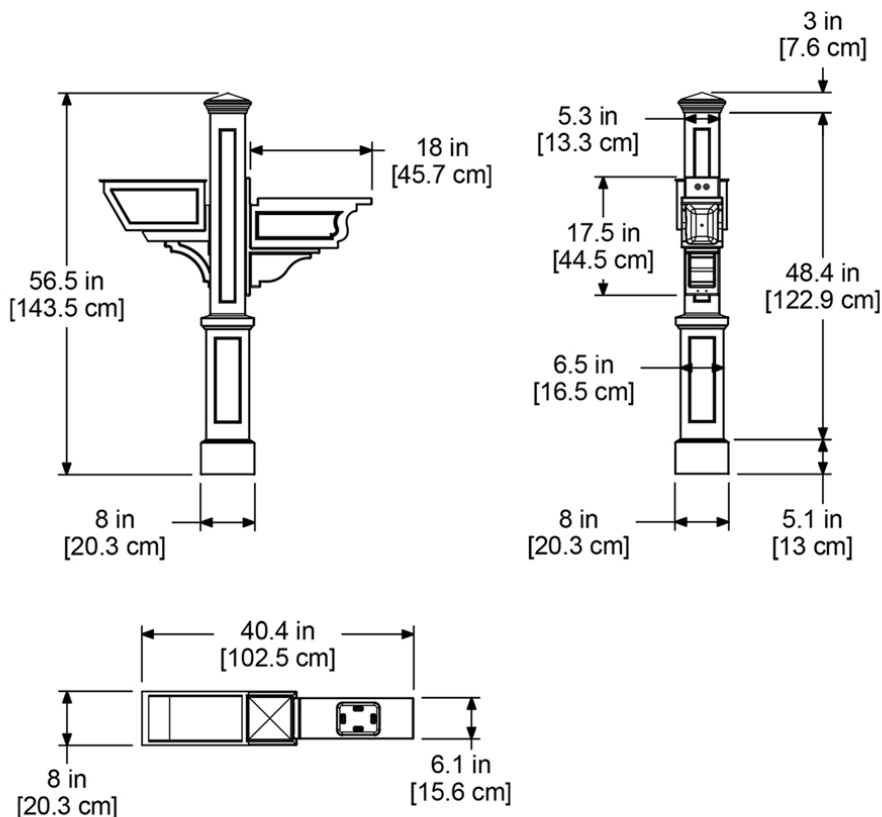
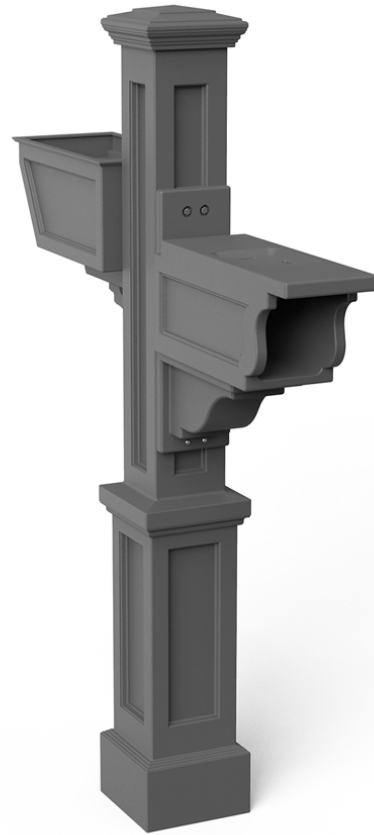

MAYNE[®]
Outdoor Products of Distinction

7024 Kilbourne Rd - Unit A London, ON N6P 1K6

Tel: 866-363-8834 | www.gomayne.com

customerservice@gomayne.com