

Nantucket

Model # 4846

Nantucket 20in Square Planter



DESCRIPTION

The Nantucket 20x20 Square planter features classic panels with a smooth polished finish. Stylish, strong, and timeless – this planter is the perfect way to outfit your home or office.

- 100% polyethylene planter with UV inhibitors
- Weather resistant, low maintenance material
- Double wall design featuring a sub-irrigation water system
- Warranty: 15-Yr Residential Use / 5-Yr Commercial Use

PRODUCT DIMENSIONS

Outside Dimensions: 20in L x 20in W x 20in H (50.8cm x 50.8cm x 50.8cm)

Inside Dimensions: 15.7in L x 15.7in W x 13in D (39.9cm x 39.9cm x 33cm)

Soil Capacity: 10.9 Gallons (41 Liters)

Water Reservoir Capacity: 7.5 Gallons (28.4 Liters)

Wall Thickness: 0.125in (3.2mm)

Part Weight: 12.8lbs (5.8kg)

Material: Polyethylene

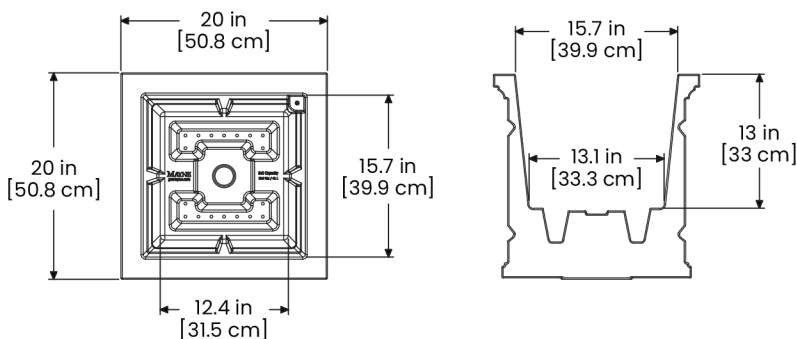
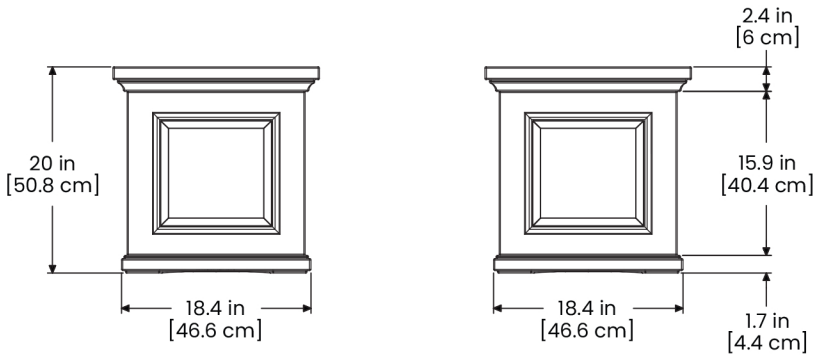
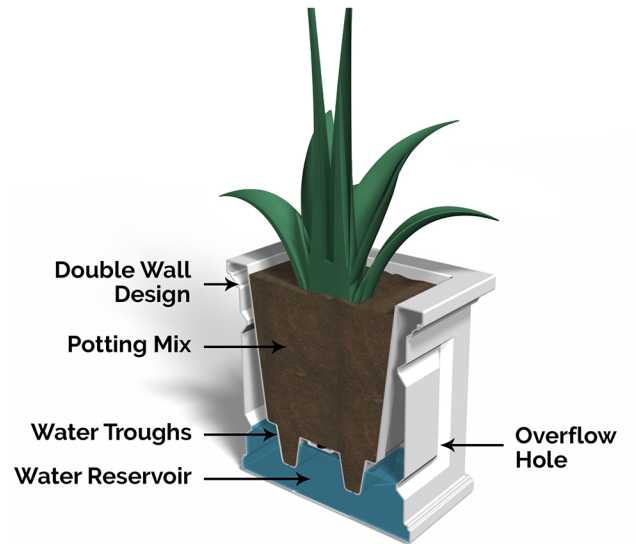

MAYNE[®]
Outdoor Products of Distinction

7024 Kilbourne Rd - Unit A
London, ON N6P 1K6
866-363-8834 | gomayne.com
customerservice@gomayne.com