

Nantucket

Model # 4828

Nantucket Decorative Brackets



DESCRIPTION

Complete the look of your Nantucket window box with a pair of decorative supports. The curved brackets are the perfect finishing touch to your installation.

- Made from 100% high-grade polyethylene
- Designed specifically for Nantucket window boxes
- Brackets attach easily to the existing wall mount brackets
- Weather resistant, low maintenance material
- Warranty: 15-Yr Residential Use / 5-Yr Commercial Use



PRODUCT DIMENSIONS

Outside Dimensions: 8in L x 3.9in W x 7in H (20.3cm x 9.9cm x 17.8cm)

Wall Thickness: 0.125in (3.17mm)

Part Weight: 1.4lbs (0.6kg)

Material: Polyethylene

Contents: 2 decorative brackets and 4 mounting screws

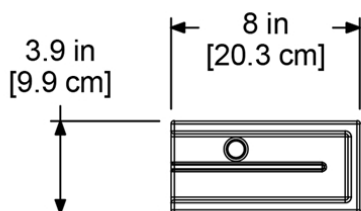
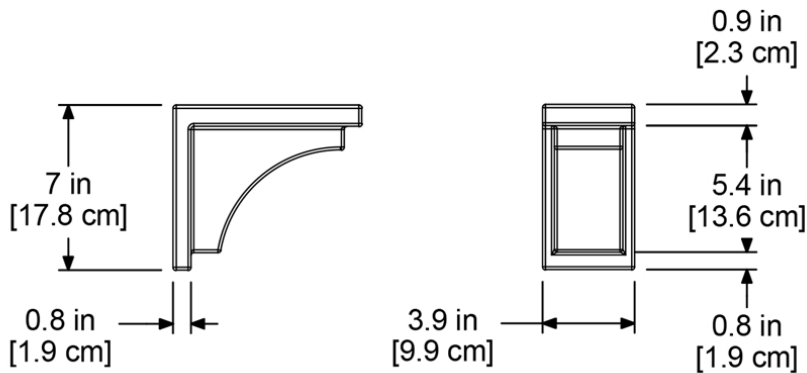

MAYNE[®]
Outdoor Products of Distinction

7024 Kilbourne Rd - Unit A London, ON N6P 1K6

Tel: 866-363-8834 | www.gomayne.com

customerservice@gomayne.com