

NOTES:

(N1) 1. FIT / FORM / FUNCTION SHALL FOLLOW PS-E.008.

BILL OF MATERIAL (CURRENT LEVEL)

ITEM	PT/ASSY	DESCRIPTION	TYPE	QTY.
1	3-401	R/T SPOUT ASM	ASSEMBLY	1
2	3-608	LEVER HADNLE	ASSEMBLY	3
3	6-289-7	HANDSHOWER-ESC ASM	ASSEMBLY	1
4	284	59 IN. SPIRAL SHOWER HOSE	ASSEMBLY	1
5	283-101	ROUND WAND HANDSHOWER	ASSEMBLY	1

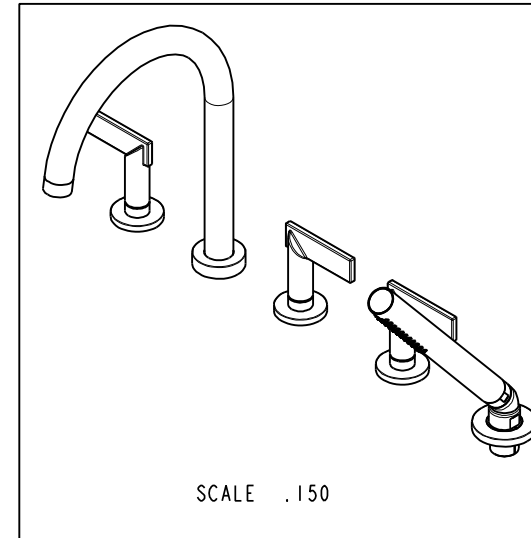
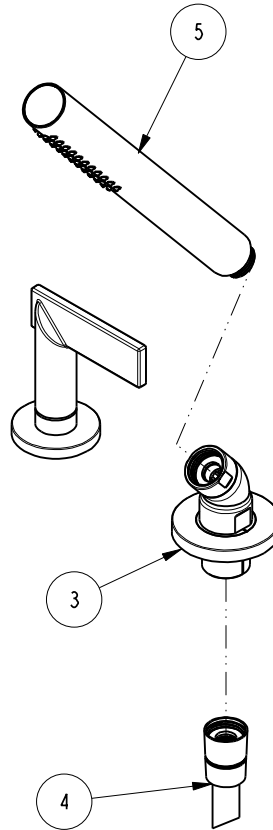
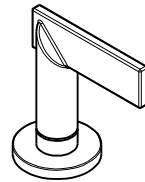
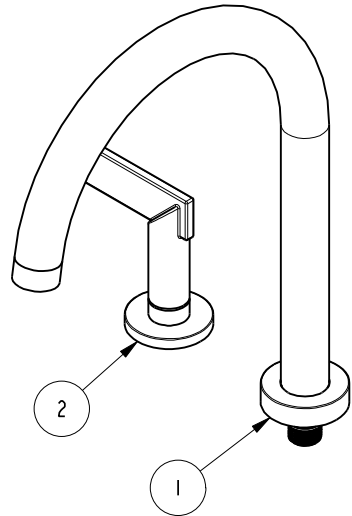

-	J	EN-3397	06/05/18	J.A.
-	H	EN-3334	01/08/18	J.A.
-	G	EN-2541-1	09/05/14	-
-	F	EN-2188A	12/12/12	-
-	E	EN-2233	07/30/12	-
-	D	EN-2143	04/18/12	-
-	C	EN-2036	01/17/12	-
-	B	EN-1993	11/30/11	-
-	A	EN-1839	08/09/11	-
-	-	EN-0995-3	01/31/11	-
ZONE	REV	DESCRIPTION	DATE	APPROVED

COPYRIGHT 2005 BRASSTECH, INC. THESE DRAWINGS AND THE DESIGNS DEPICTED HEREIN ARE THE PROPRIETARY PROPERTY OF BRASSTECH. ANY USE OR REPRODUCTION IS SUBJECT TO THE EXPRESS APPROVAL OF BRASSTECH. UNAUTHORIZED USE IS STRICTLY PROHIBITED. ALL RIGHTS RESERVED.

TESTING	-	-	-
ASSEMBLY	-	-	-
PLATING	-	-	-
POLISHING	-	NEXT ASSY	USED ON
MACHINING	-	APPLICATION	
TOOLING FIXTURE #	REMOVE ALL BURRS AND SHARP EDGES		

UNITS ARE: INCHES [MM]	
TOLERANCES ARE:	
FRACTIONS DECIMALS	ANGLES
$\pm 1/16"$	$\pm 1^\circ$
$.X \pm .1$ [2,5]	
$.XX \pm .06$ [1,5]	
(X.XXX) DENOTES CRITICAL DIMS. ALL THREADS ARE CRITICAL	
DRAWN	JINSON 06/05/18
CHECKED	J.A. 06/05/18
APPROVED	J.A. 06/05/18

BRASSTECH 2001 CARNEGIE AVE. SANTA ANA, CA 92705 (949) 417-5207
INCORPORATED

R/T BATHSET C-SPOUT W/HAND SHOWER

DWG NO. **3-2487** REV **J**

SCALE .250 REF. SHEET | OF 3

4

3

2

1

D

D

C

C

B

B

A

A

PN: 1-698
SOLD SEPARATELY

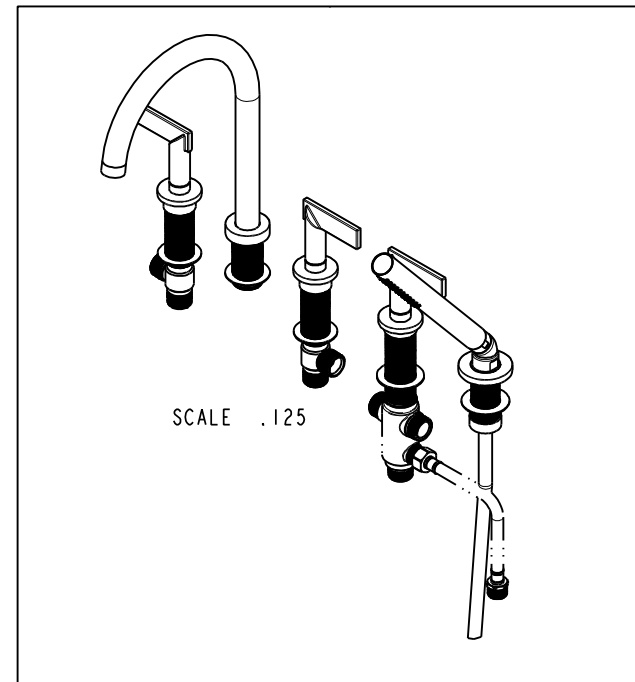
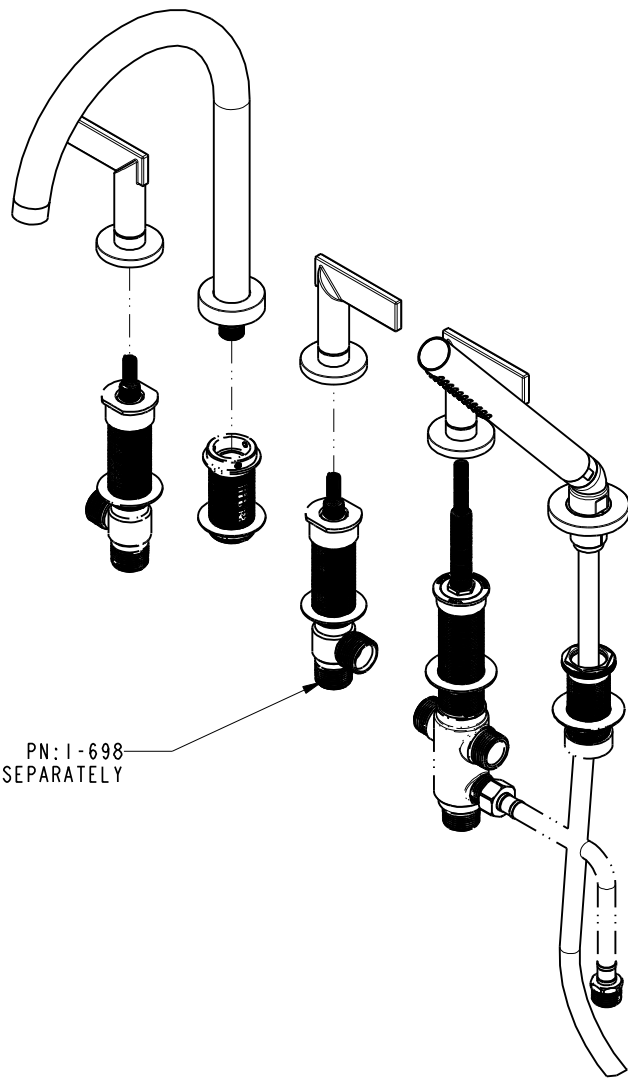

SCALE .125

BRASSTECH INCORPORATED		2001 E. CARNEGIE AVE. SANTA ANA, CA 92705 (949) 417-5207	
DWG NO.	3-2487	REV	J
SCALE .188	REF.	SHEET 2	OF 3

4

3

2

1

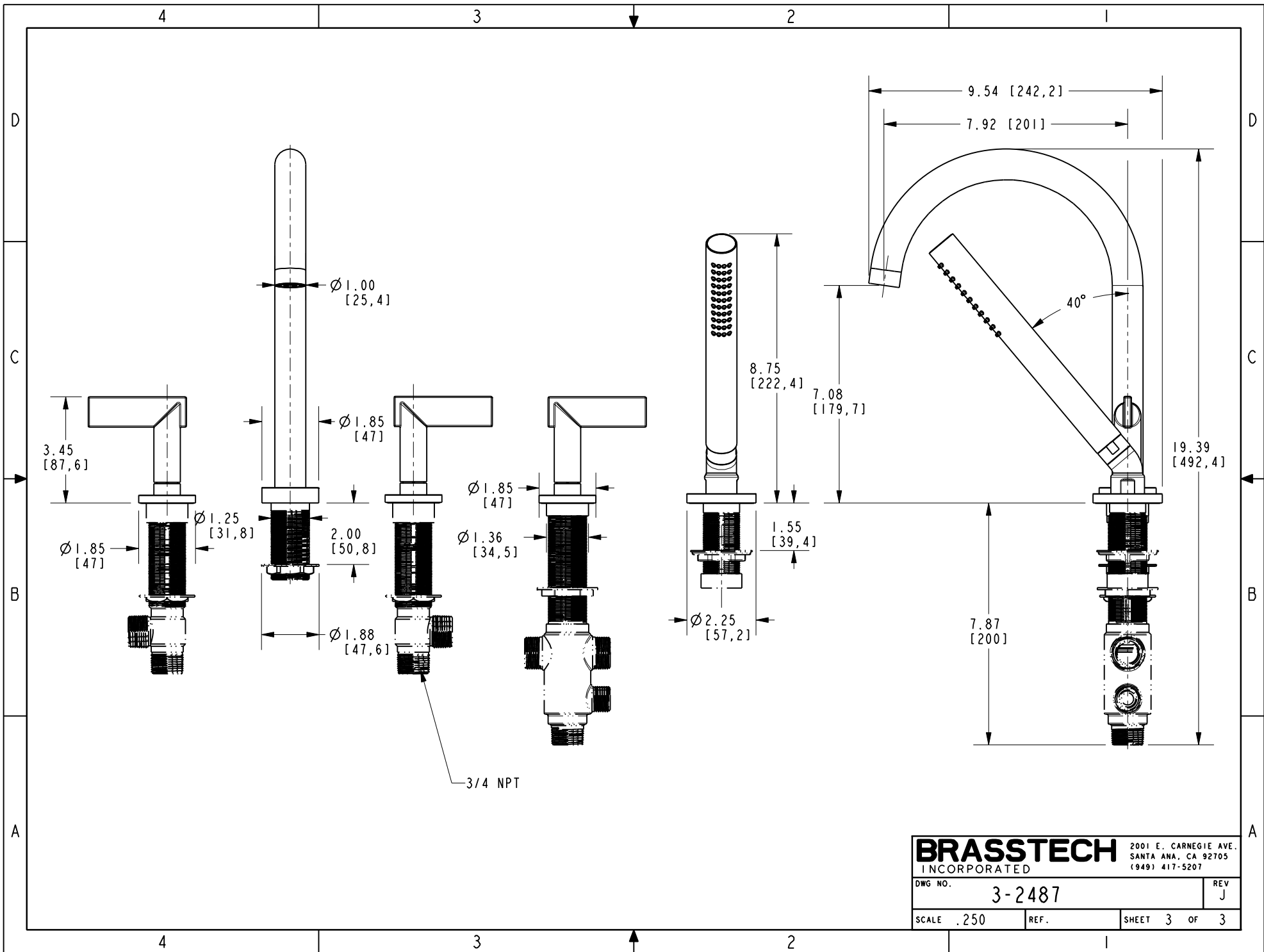

BRASSTECH		2001 E. CARNEGIE AVE.	
INCORPORATED		SANTA ANA, CA 92705	
DWG NO. 3-2487		REV J	
SCALE .250	REF.	SHEET 3	OF 3