

NOTES:

(NI) 1. FIT / FORM / FUNCTION SHALL FOLLOW PS-E.008.

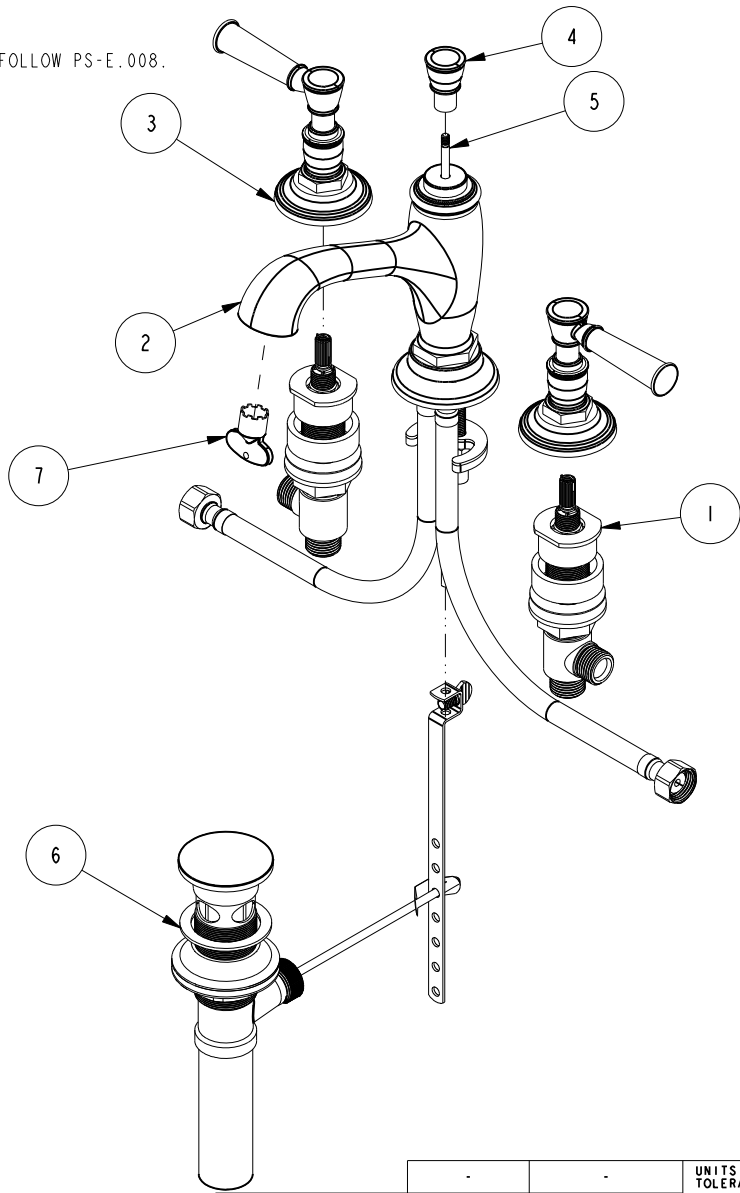

BILL OF MATERIAL (CURRENT LEVEL)

ITEM	PT/ASSY	DESCRIPTION	TYPE	QTY.
1	1-676	W/S VALVE INSTALLATION	ASSEMBLY	1
2	20-114	W/S SPOUT ASM	ASSEMBLY	1
3	3-561	LEVER HANDLE W/ESC.	ASSEMBLY	2
4	12372	BONNET	PART	1
5	10288	3/16" POP UP ROD	PART	1
6	325	POP UP ASSEMBLY	ASSEMBLY	1
7	91571	AERATOR KEY	PART	1

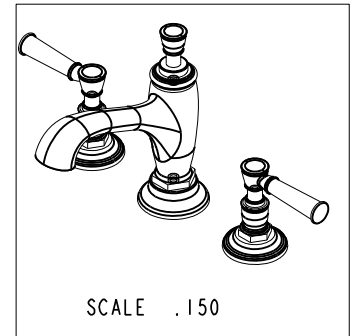

UNITS ARE: INCHES [MM]
TOLERANCES ARE:
FRACTIONS DECIMALS ANGLES
±1/16" .X ±.1 [2.5] ±1°
.XX ±.06 [1.5]

(X.XXX) DENOTES CRITICAL DIMS.
ALL THREADS ARE CRITICAL

DRAWN RAVINDRA 08/10/15
CHECKED JINSON 08/10/15
APPROVED J.M 08/10/15

BRASSTECH 2001 CARNEGIE AVE.
INCORPORATED SANTA ANA, CA 92705
(949) 417-5207

W/S LAVATORY ASSEMBLY

DWG NO. 2910 REV A
SCALE .225 REF. SHEET 1 OF 2

ZONE	REV	DESCRIPTION	DATE	APPROVED
-	A	EN-3601	05/07/18	V.V.
-	-	EN-2838c	08/10/15	J.M

COPYRIGHT 2005 BRASSTECH, INC.
THESE DRAWINGS AND THE DESIGNS
DEPICTED HEREIN ARE THE PROPRIETARY
PROPERTY OF BRASSTECH. ANY USE
OR REPRODUCTION IS SUBJECT TO
THE EXPRESS APPROVAL OF BRASSTECH.
UNAUTHORIZED USE IS STRICTLY
PROHIBITED. ALL RIGHTS RESERVED.

TESTING	ASSEMBLY	PLATING	POLISHING	MACHINING	TOOLING FIXTURE #	APPLICATION
-	-	-	-	-	-	REMOVE ALL BURRS AND SHARP EDGES

