

NOTES:

- (NI) 1. FIT / FORM / FUNCTION SHALL FOLLOW PS-E.008.
- 2. APPLY LOCTITE 680.
- 3. APPLY TORQUE OF 8-10 LB-IN.

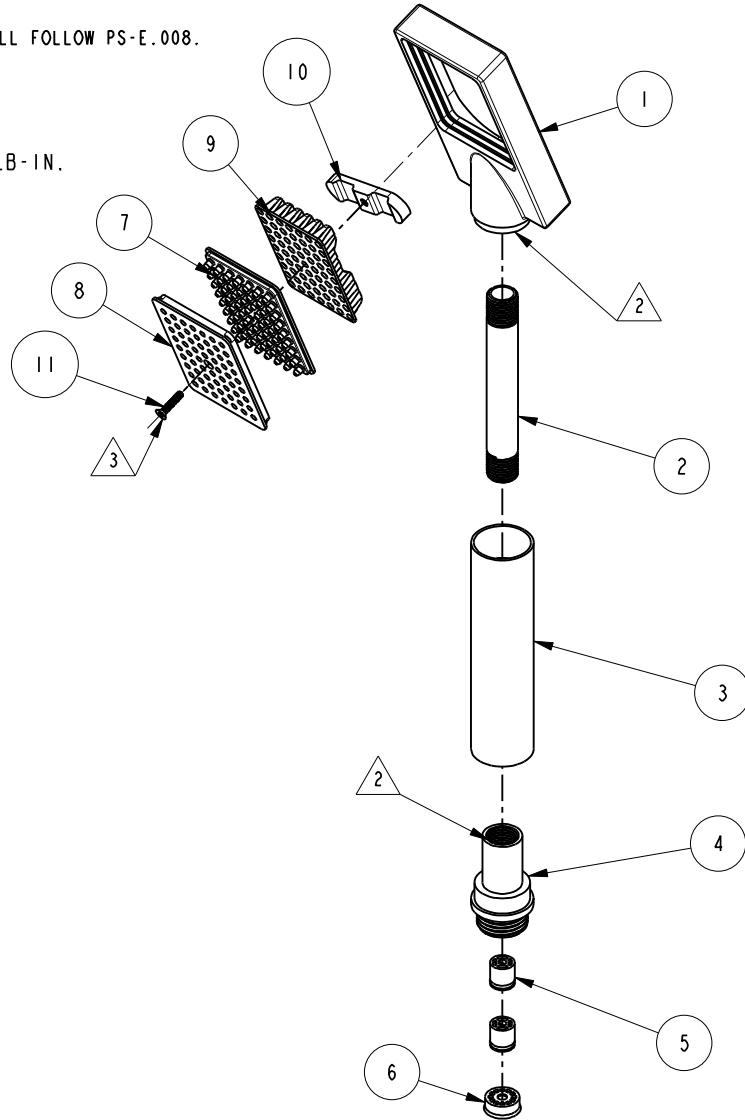

BILL OF MATERIAL (CURRENT LEVEL)

ITEM	PT/ASSY	DESCRIPTION	TYPE	QTY.
1	80041	HAND SHOWER HEAD	PART	1
2	50915	NIPPLE	PART	1
3	80044	HANDLE SLEEVE	PART	1
4	50913	END NUT	PART	1
5	5-050	CHECK VALVE, NEOPERL DWIO, WHITE	PART	2
6	12832	FLOW REGULATOR, 1.8 GPM MAX	PART	1
7	12324	JET SPRAY MEMBRANE	PART	1
8	80042	HANDSHOWER FACE PLATE	PART	1
9	12325	SPRAY SUPPORT ADAPTER	PART	1
10	12326	MOUNTING PLATE	PART	1
11	92556	SCRW, 4-40 X 1/2 TORX FLT HD SS	PART	1

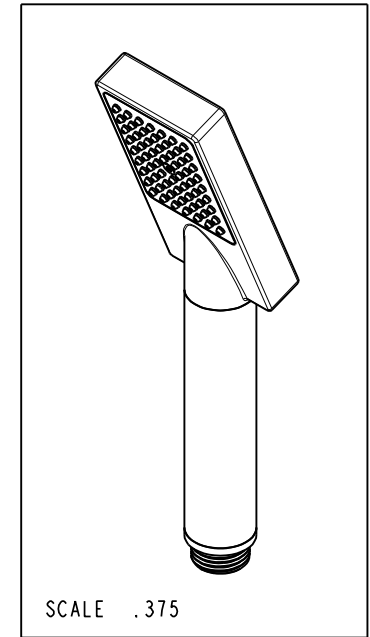

-	H	EN-3410	01/02/18	C.G.
-	G	EN-3052	06/06/16	R.S
-	F	EN-2787	01/28/15	-
-	E	EN-2145	04/20/12	-
-	D	EN-1878	09/16/11	-
-	C	EN-1735	06/10/11	-
-	B	EO-0927	12/21/07	-
-	A	EO-0579	10/11/05	-
ZONE	REV	DESCRIPTION	DATE	APPROVED

COPYRIGHT 2005 BRASSTECH, INC. THESE DRAWINGS AND THE DESIGNS DEPICTED HEREIN ARE THE PROPRIETARY PROPERTY OF BRASSTECH. ANY USE OR REPRODUCTION IS SUBJECT TO THE EXPRESS APPROVAL OF BRASSTECH. UNAUTHORIZED USE IS STRICTLY PROHIBITED. ALL RIGHTS RESERVED.

TESTING	-	-	-
ASSEMBLY	-	-	-
PLATING	-	2567	2567
POLISHING	-	NEXT ASSY	USED ON
MACHINING	-	APPLICATION	
TOOLING FIXTURE #	REMOVE ALL BURRS AND SHARP EDGES		

UNITS ARE: INCHES [MM]		
TOLERANCES ARE:		
FRACTIONS DECIMALS	ANGLES	
±1/16"	.X ±.1 [2.5]	±1°
	.XX ±.06 [1.5]	
(X.XXX) DENOTES CRITICAL DIMS. ALL THREADS ARE CRITICAL		
DRAWN	JINSON	01/02/18
CHECKED	C.G.	01/02/18
APPROVED	C.G.	01/02/18

<b>BRASSTECH</b>		2001 CARNEGIE AVE. SANTA ANA, CA 92705 (949) 417-5207	
INCORPORATED			
<b>HANDSPRAY ASSEMBLY</b>			
DWG NO.		REV	
283-4		H	
SCALE	REF.	SHEET	OF
.325	-	1	2

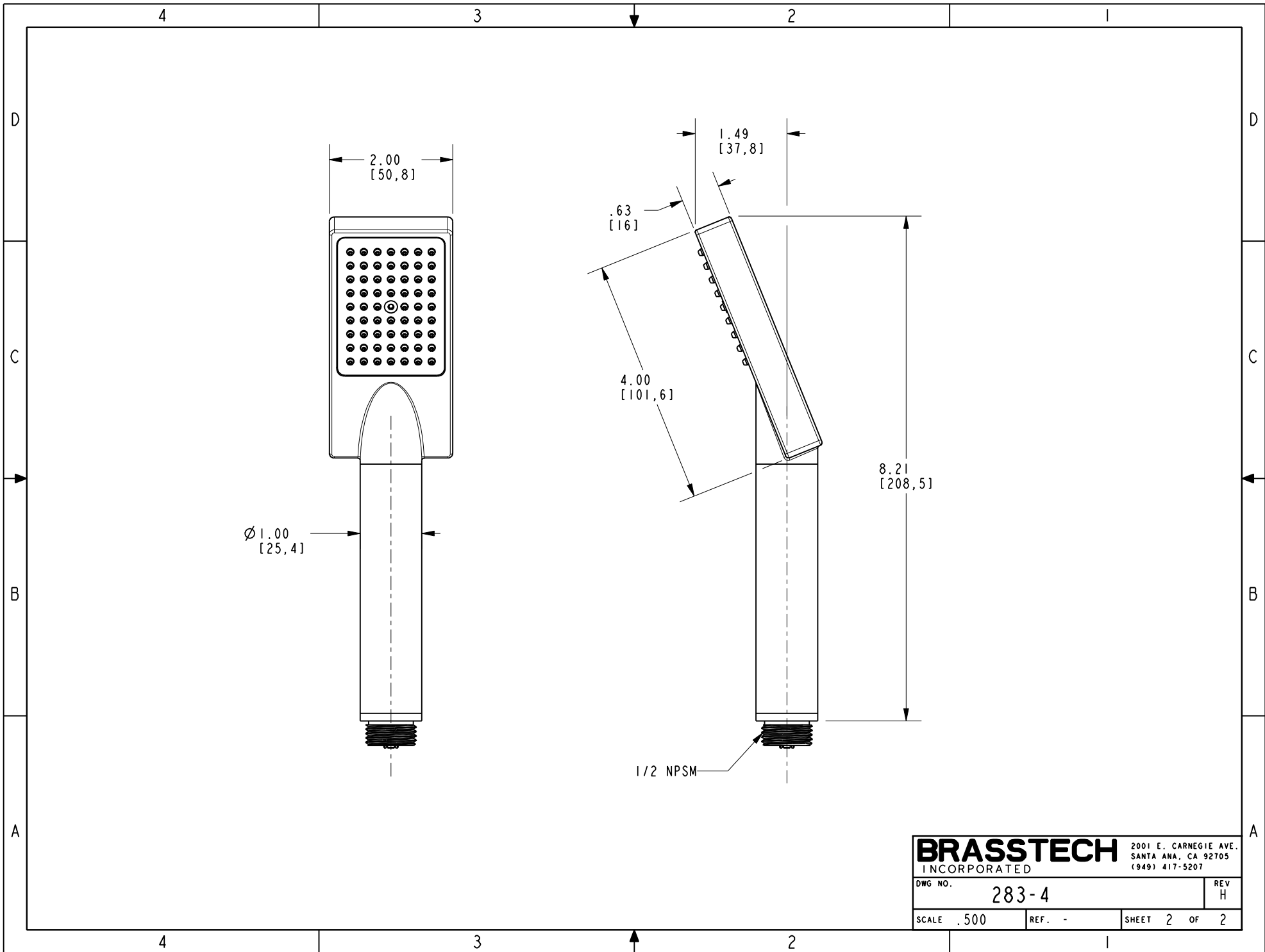

<b>BRASSTECH</b>		2001 E. CARNEGIE AVE.	
INCORPORATED		SANTA ANA, CA 92705	
DWG NO. 283-4		REV H	
SCALE .500	REF. -	SHEET 2 OF 2	