

4

3

2

1

NOTES:

- (N1) 1. FIT / FORM / FUNCTION SHALL FOLLOW PS-E.008.
- (N2) 2. PUT THESE ITEMS IN SEPARATE PLASTIC BAGS.
- 3. TORQUE TO 7.5-8.5 LB-FT.
- 4. APPLY THIN COAT OF SILICON GREASE FOR ALL O-RINGS BEFORE INSTALLATION.
- 5. APPLY LOCTITE 242, IF SCREW DOES NOT HAVE NYLON PATCH.

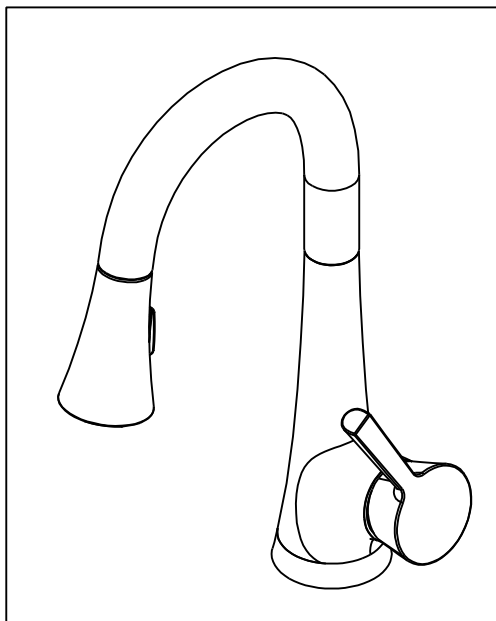

BILL OF MATERIAL (CURRENT LEVEL)

ITEM	PT/ASSY	DESCRIPTION	TYPE	QTY.
1	2-784	BASE RING ASM	ASSEMBLY	1
2	2-946	MAIN BODY ASM , VESPERA	ASSEMBLY	1
3	12753	SPOUT ADAPTER	PART	1
4	1-064	SINGLE LEVER CARTRIDGE	PART	1
5	11713	CARTRIDGE STEM ADAPTER	PART	1
6	92035	SCRW, M4 X .7 X 10 PHL FLT HD SS	PART	1
7	91534	CARTRIDGE STEM INSERT	PART	1
8	11714	CARTRIDGE RETAINER	PART	1
9	11715	CARTRIDGE CAP	PART	1
10	91645	SLEEVE	PART	1
11	2-790	HANDLE ASM	ASSEMBLY	1
12	91030	O-RING, #2- 115, EPDM, 65-75 DURO, NSF 61	PART	4
13	12494	SPOUT	PART	1
14	91544	MAGNET DOCKING	ASSEMBLY	1
15	3-463	SPRAY HEAD, VESPERA	ASSEMBLY	1
16	1-256	MOUNTING KIT	ASSEMBLY	1
17	91568	RETAINER CLIP	PART	1
18	11877	HOSE, PULLDOWN SWIVEL	ASSEMBLY	1
19	91255	O-RING, #2- 011, EPDM, 65-75 DURO, NSF-61	PART	2
20	91341	ZIP TIE	PART	1
21	98044	LABEL - HOT	PART	1
22	1-286	WEIGHT ASM	ASSEMBLY	1

D

D

C

C

B

B

A

A

-	D	EN-3034F	04/20/17	J.A
-	C	EN-3034	04/13/17	J.A
-	B	EN-2821	10/16/14	-
-	A	EN-2700	02/20/14	-
-	-	EN-2680	01/22/14	-
ZONE	REV	DESCRIPTION	DATE	APPROVED

COPYRIGHT 2005 BRASSTECH, INC. THESE DRAWINGS AND THE DESIGNS DEPICTED HEREIN ARE THE PROPRIETARY PROPERTY OF BRASSTECH. ANY USE OR REPRODUCTION IS SUBJECT TO THE EXPRESS APPROVAL OF BRASSTECH. UNAUTHORIZED USE IS STRICTLY PROHIBITED. ALL RIGHTS RESERVED.

TESTING	-	-	-
ASSEMBLY	-	-	-
PLATING	-	-	-
POLISHING	-	NEXT ASSY	USED ON
MACHINING	-	APPLICATION	
TOOLING	FIXTURE #	REMOVE ALL BURRS AND SHARP EDGES	

UNITS ARE: INCHES [MM]
TOLERANCES ARE:
FRACTIONS DECIMALS ANGLES
±1/16" .X ±.1 [2,5] ±1°
.XX ±.06 [1,3]

(X.XXX) DENOTES CRITICAL DIMS.
ALL THREADS ARE CRITICAL

DRAWN	AMARISH	04/20/17
CHECKED	RAVINDRA	04/20/17
APPROVED	J.A	04/20/17

BRASSTECH 2001 CARNEGIE AVE.
INCORPORATED SANTA ANA, CA 92705
(949) 417-5207

VESPERA PULL DOWN - BAR /
PREP FAUCET

DWG NO. 2500-5223 REV D

SCALE .250 REF. - SHEET 1 OF 3

4

3

2

1

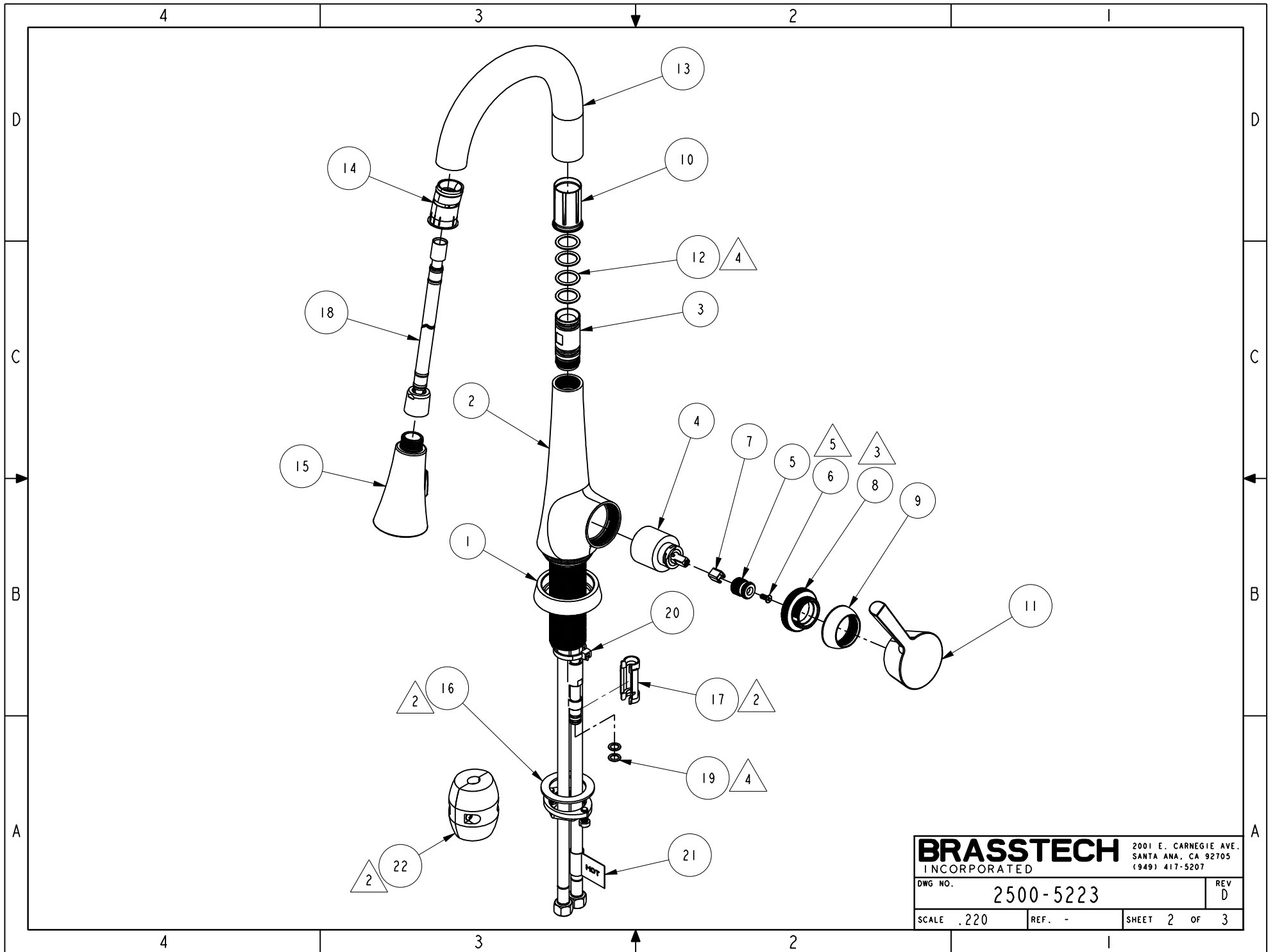

BRASSTECH		2001 E. CARNEGIE AVE.
INCORPORATED		SANTA ANA, CA 92705
		(949) 417-5207
DWG NO.	2500-5223	REV D
SCALE .220	REF. -	SHEET 2 OF 3

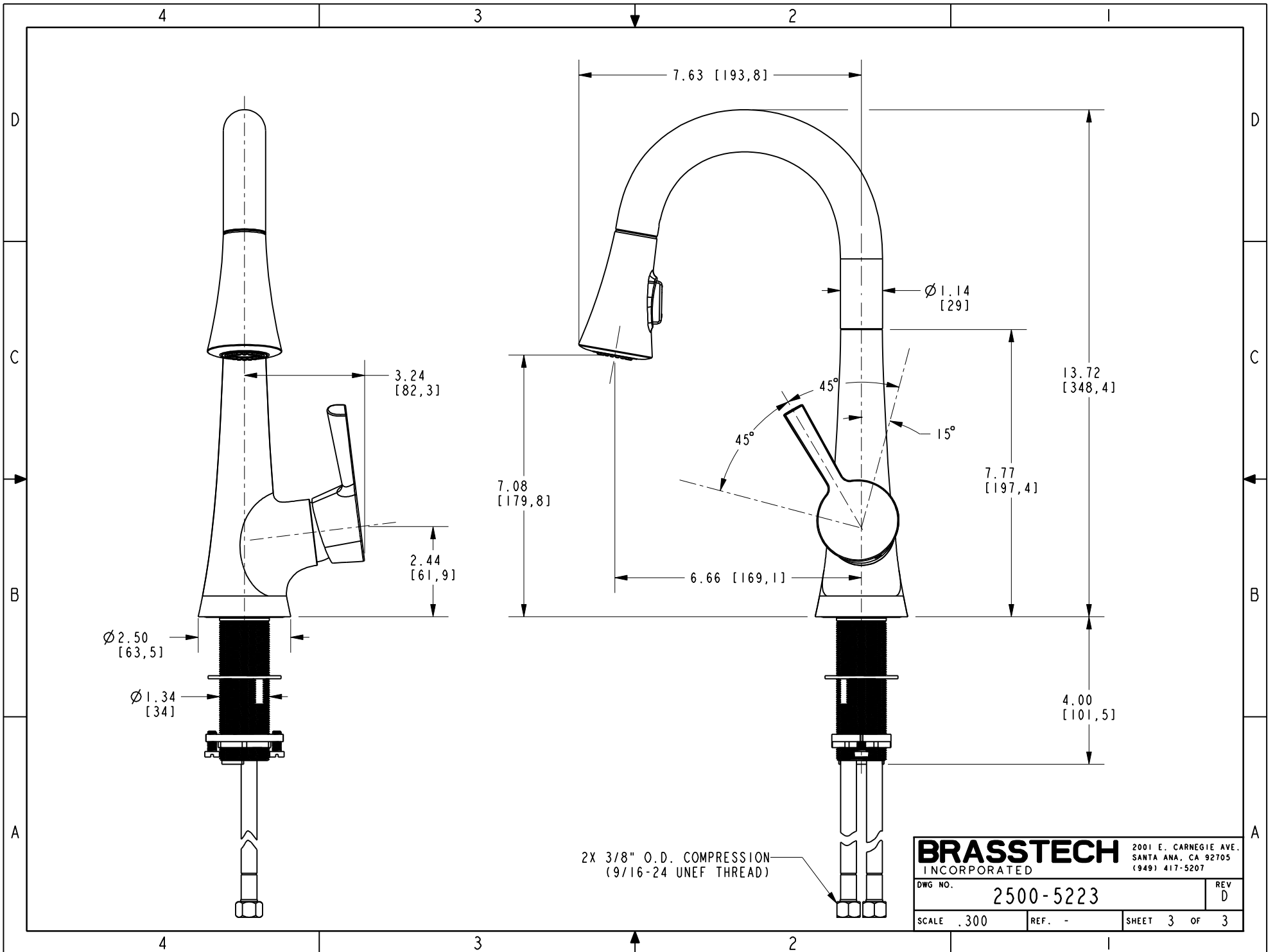

2X 3/8" O.D. COMPRESSION
(9/16-24 UNEF THREAD)

BRASSTECH		2001 E. CARNEGIE AVE.	
INCORPORATED		SANTA ANA, CA 92705	
		(949) 417-5207	
DWG NO.	2500-5223	REV	D
SCALE	.300	REF.	-
		SHEET	3 OF 3