

NOTES:

(NI) 1. FIT / FORM / FUNCTION SHALL FOLLOW PS-E.008.

BILL OF MATERIAL (CURRENT LEVEL)

ITEM	PT/ASSY	DESCRIPTION	TYPE	QTY.
1	3-402	W/S - MITER SPOUT ASM	ASSEMBLY	1
2	3-608	LEVER HADNLE	ASSEMBLY	2
3	1-676	W/S VALVE INSTALLATION	ASSEMBLY	1
4	11738	POP UP KNOB	PART	1
5	10288	3/16" POP UP ROD	PART	1
6	325	POP UP ASSEMBLY	ASSEMBLY	1
7	91571	AERATOR KEY	PART	1

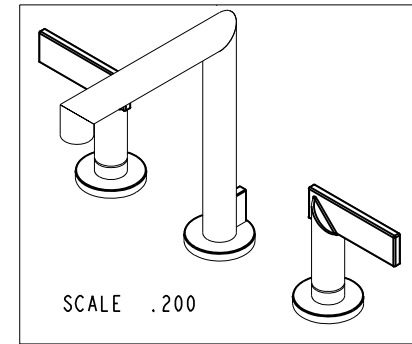

SCALE .200

ZONE	REV	DESCRIPTION	DATE	APPROVED
-	D	EN-3601	05/07/18	V.V.
-	C	EN-3334	01/05/18	J.A.
-	B	EN-3051	07/06/16	J.A.
-	A	EN-2541-1	09/05/14	JW
-	-	EN-0995-3	01/31/11	-

COPYRIGHT 2005 BRASSTECH, INC. THESE DRAWINGS AND THE DESIGNS DEPICTED HEREIN ARE THE PROPRIETARY PROPERTY OF BRASSTECH. ANY USE OR REPRODUCTION IS SUBJECT TO THE EXPRESS APPROVAL OF BRASSTECH. UNAUTHORIZED USE IS STRICTLY PROHIBITED. ALL RIGHTS RESERVED.

TESTING	ASSEMBLY	PLATING	POLISHING	MACHINING	TOOLING FIXTURE #	APPLICATION
-	-	-	-	-	-	REMOVE ALL BURRS AND SHARP EDGES
-	-	-	-	-	-	-
-	-	-	-	-	-	-
-	-	-	-	-	-	-
-	-	-	-	-	-	-

UNITS ARE: INCHES [MM]
TOLERANCES ARE:
FRACTIONS DECIMALS ANGLES
±1/16" .X ±.1 [2.5] ±1°
.XX ±.06 [1.5]

(X.XXX) DENOTES CRITICAL DIMS. ALL THREADS ARE CRITICAL

DRAWN	JINSON	01/05/18
CHECKED	J.A.	01/05/18
APPROVED	J.A.	01/05/18

BRASSTECH 2001 CARNEGIE AVE. SANTA ANA, CA 92705 (949) 417-5207
INCORPORATED

W/S MITER DECK LAVATORY SET

DWG NO. **2490** REV **D**

SCALE .250 REF. - SHEET 1 OF 2

