

NOTES:

- (N1) 1. FIT / FORM / FUNCTION SHALL FOLLOW PS-E.008.
- (N2) \triangle 2 WHEN TIGHTENING ITEM 3 IN ASSY , APPLY 50-60 LB-IN OF TORQUE

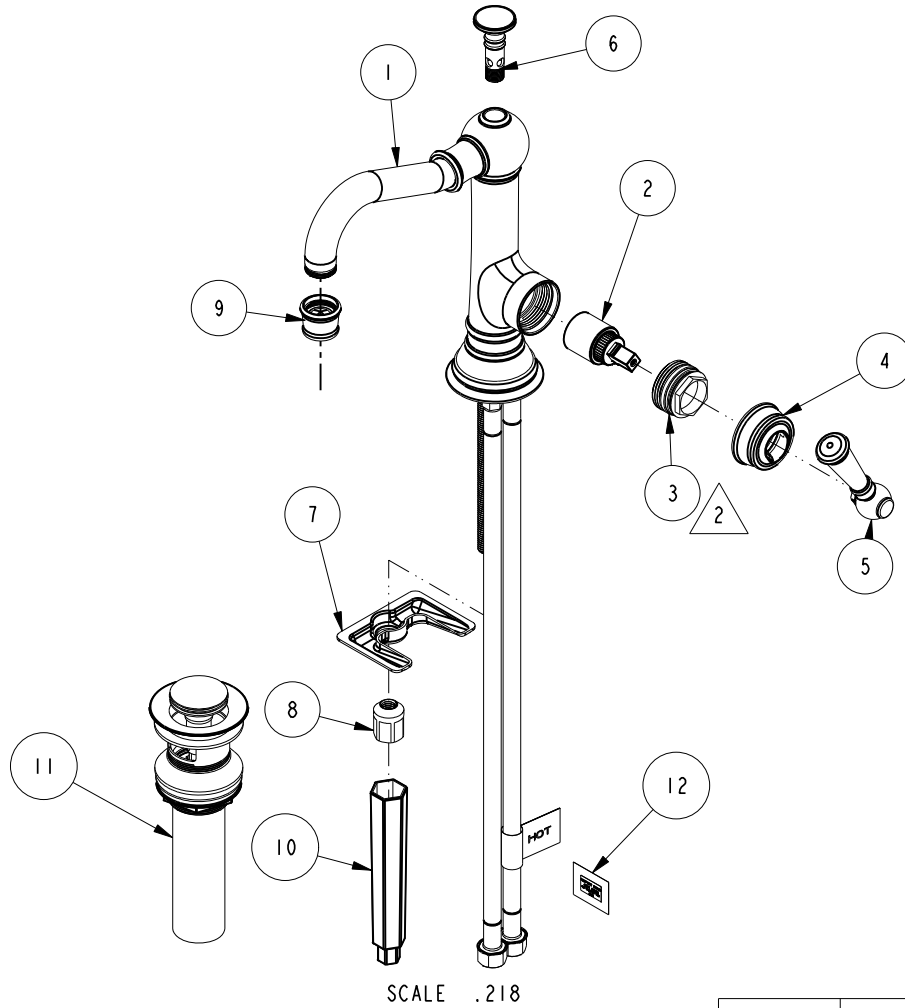

BILL OF MATERIAL (CURRENT LEVEL)

ITEM	PT/ASSY	DESCRIPTION	TYPE	QTY.
1	2-821	SPOUT BODY ASM	ASSEMBLY	1
2	1-242	CARTRIDGE 25 MM KCG K025a	PART	1
3	1-274	CARTRIDGE RETAINER ASM	ASSEMBLY	1
4	2-831	CARTRIDGE BONNET ASM	ASSEMBLY	1
5	2-832	LEVER ASM	ASSEMBLY	1
6	2-833	FINIAL ASM	ASSEMBLY	1
7	11280	MOUNTING BRACKET	PART	1
8	11285	MOUNTING NUT	PART	1
9	2-658	AERATOR ASM	ASSEMBLY	1
10	92297	INSTALLATION TOOL, WRENCH	PART	1
11	330	DRAIN, PUSH DOWN, W/ OVERFLOW	ASSEMBLY	1
12	98109	NEWPORT BRASS LABEL	PART	1

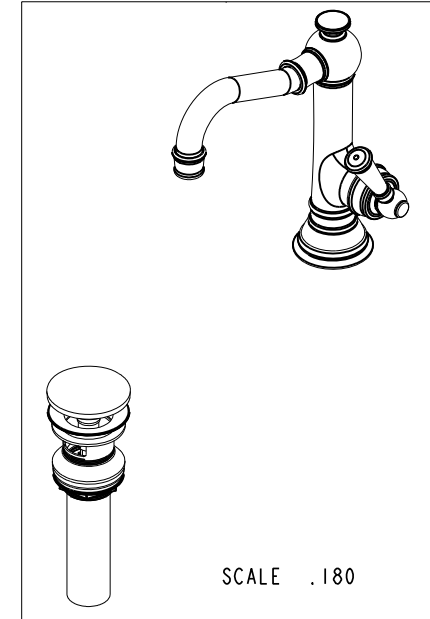

ZONE	REV	DESCRIPTION	DATE	APPROVED
-	C	EN-3718	09/28/18	C.G.
-	B	EN-2919	07/17/15	J.M.
-	A	EN-2643	05/30/14	-
-	-	EN-1883	04/11/12	-

COPYRIGHT 2005 BRASSTECH, INC. THESE DRAWINGS AND THE DESIGNS DEPICTED HEREIN ARE THE PROPRIETARY PROPERTY OF BRASSTECH. ANY USE OR REPRODUCTION IS SUBJECT TO THE EXPRESS APPROVAL OF BRASSTECH. UNAUTHORIZED USE IS STRICTLY PROHIBITED. ALL RIGHTS RESERVED.

TESTING	-	-	-
ASSEMBLY	-	-	-
PLATING	-	-	-
POLISHING	-	NEXT ASSY	USED ON
MACHINING	-	APPLICATION	
TOOLING FIXTURE #	REMOVE ALL BURRS AND SHARP EDGES		

UNITS ARE: INCHES [MM]	
TOLERANCES ARE:	
FRACTIONS	DECIMALS
$\pm 1/16"$	$\pm .005$
$.X \pm .1$ [2.5]	$\pm 1"$
$.XX \pm .06$ [1.5]	
(X.XXX) DENOTES CRITICAL DIMS. ALL THREADS ARE CRITICAL	
DRAWN	C. GAYOSSO 09/28/18
CHECKED	V. VU 09/28/18
APPROVED	V. VU 09/28/18

BRASSTECH INCORPORATED
 2001 CARNEGIE AVE.
 SANTA ANA, CA 92705
 (949) 417-5207

SINGLE HOLE LAV FAUCET

DWG NO. **2473** REV **C**

SCALE .250 REF. - SHEET 1 OF 2

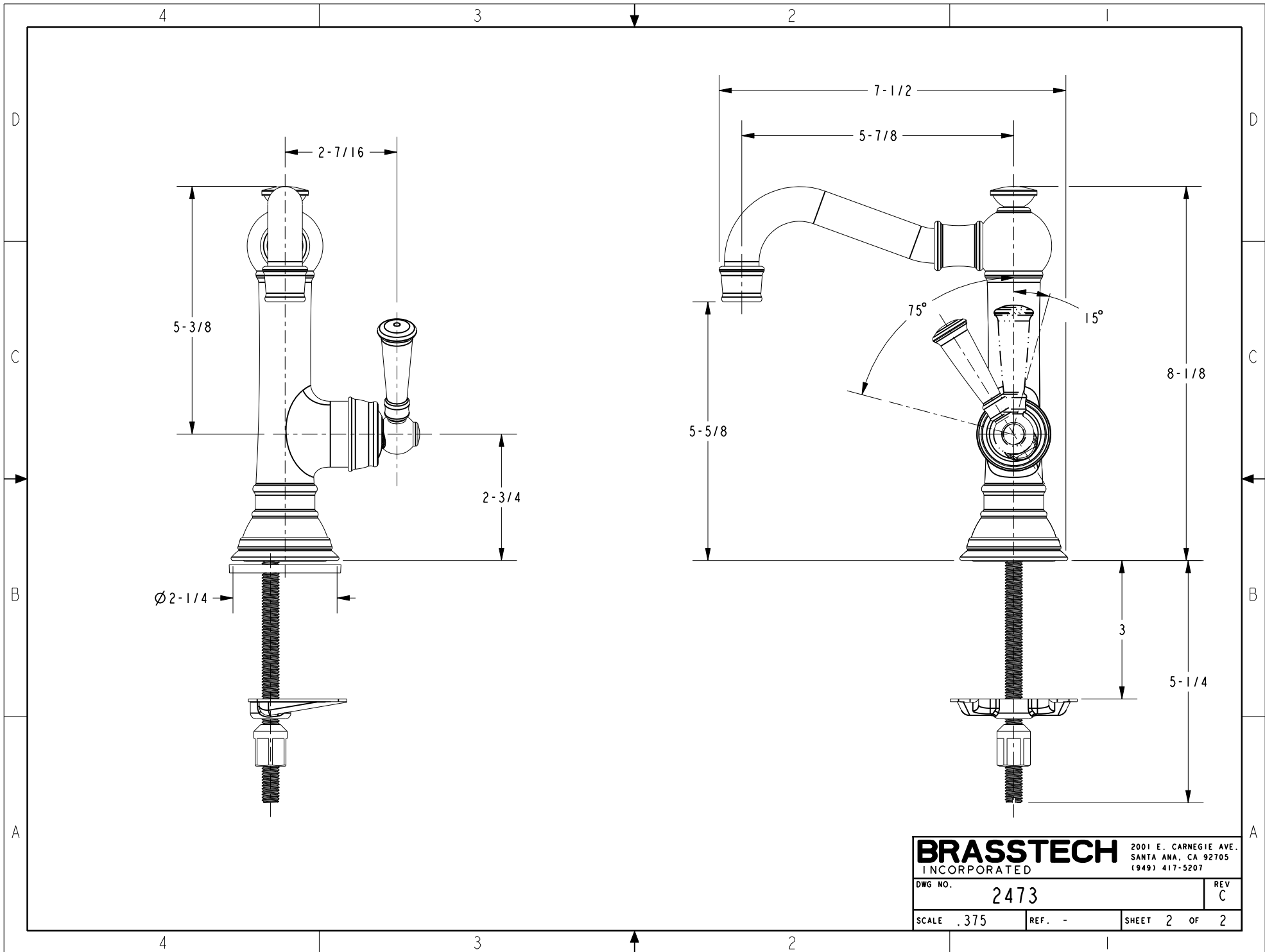

BRASSTECH		2001 E. CARNEGIE AVE.	
INCORPORATED		SANTA ANA, CA 92705	
DWG NO. 2473		REV C	
SCALE .375	REF. -	SHEET 2 OF 2	