

NOTES:

(N1) 1. FIT / FORM / FUNCTION SHALL FOLLOW PS-E.008.

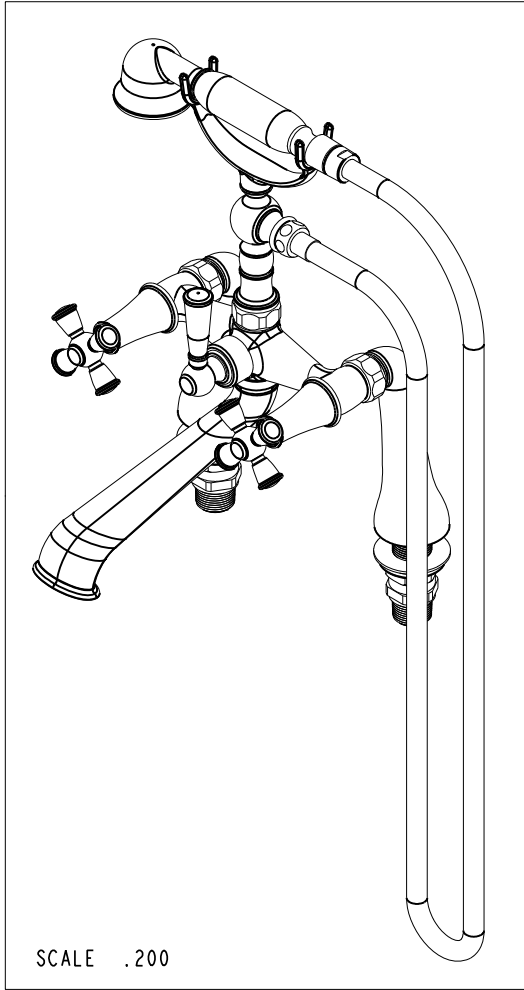

BILL OF MATERIAL (CURRENT LEVEL)

ITEM	PT/ASSY	DESCRIPTION	TYPE	QTY.
1	10326	BODY - FOR 933,934	PART	1
2	2-220	RISER ASM	ASSEMBLY	1
3	284	59 IN. SPIRAL SHOWER HOSE	ASSEMBLY	1
4	281	HANDSHOWER ASM	ASSEMBLY	1
5	12585	SPOUT	PART	1
6	91028	O-RING, #2- 113, EPDM, 65-75 DURO, NSF 61	PART	1
7	10442	SEAT FOR CARTRIDGE	PART	2
8	91020	O-RING, #2-016, EPDM, 65-75 DURO, NSF 61	PART	2
9	10332	HEX NUT	PART	2
10	91039	WSHR, .625 ID X 1.00 OD X .125 THK, RUBBER	PART	2
11	10336	LEG - LEFT	PART	1
12	10335	LEG - RIGHT	PART	1
13	1-049	MOUNTING HARDWARE	ASSEMBLY	1
14	1-076	CARTRIDGE DIVERTER ASM	ASSEMBLY	1
15	1-048	DIVERTER STOPPER ASM	ASSEMBLY	1
16	1-325	W/S CARTRIDGE FRICTION - COLD	PART	1
17	1-326	W/S CARTRIDGE FRICTION - HOT	PART	1
18	12066	HANDLE BONNET - TUB FILLER	PART	2
19	12062	ADAPTER - 20-T X 16-T	PART	2
20	2-848	C/S HANDLE BAR ASM	ASSEMBLY	1
21	2-949	CROSS HANDLE ASSY	ASSEMBLY	2
22	92538	SCRW, M4 X 25 SKT BUTTON FLANGE HD CAP BLACK-OXIDE	PART	2
23	10159	HEX KEY, 3/32 ALLOY STEEL	PART	1

TESTING	-	-	-
ASSEMBLY	-	-	-
PLATING	-	-	-
POLISHING	-	NEXT ASSY	USED ON
MACHINING	-	APPLICATION	
TOOLING FIXTURE #	REMOVE ALL BURRS AND SHARP EDGES		

BRASSTECH 2001 CARNEGIE AVE.
INCORPORATED SANTA ANA, CA 92705
(949) 417-5207

EXPOSED TUB/ HANDSHOWER,
DECK MOUNT - CROSS HANDLE





DWG NO. 2400-4272 REV C

SCALE .200 REF. - SHEET 1 OF 3

ZONE	REV	DESCRIPTION	DATE	APPROVED
-	C	EN-3447	10/27/17	V.V.
-	B	EN-3150	05/18/17	J.M.
-	A	EN-2818	11/20/14	A.N.
-	-	EN-2606	04/14/14	-

COPYRIGHT 2005 BRASSTECH, INC. THESE DRAWINGS AND THE DESIGNS DEPICTED HEREIN ARE THE PROPRIETARY PROPERTY OF BRASSTECH. ANY USE OR REPRODUCTION IS SUBJECT TO THE EXPRESS APPROVAL OF BRASSTECH. UNAUTHORIZED USE IS STRICTLY PROHIBITED. ALL RIGHTS RESERVED.

NOTES:

- (N2)  2 APPLY LOCTITE 680.
- (N3)  3 TORQUE TO 15-20 FT-LB.
- (N4)  4 APPLY LOCTITE 242 IF SCREW DOES NOT HAVE NYLON PATCH.
- (N5)  5 TORQUE TO 11-14 FT-LB.

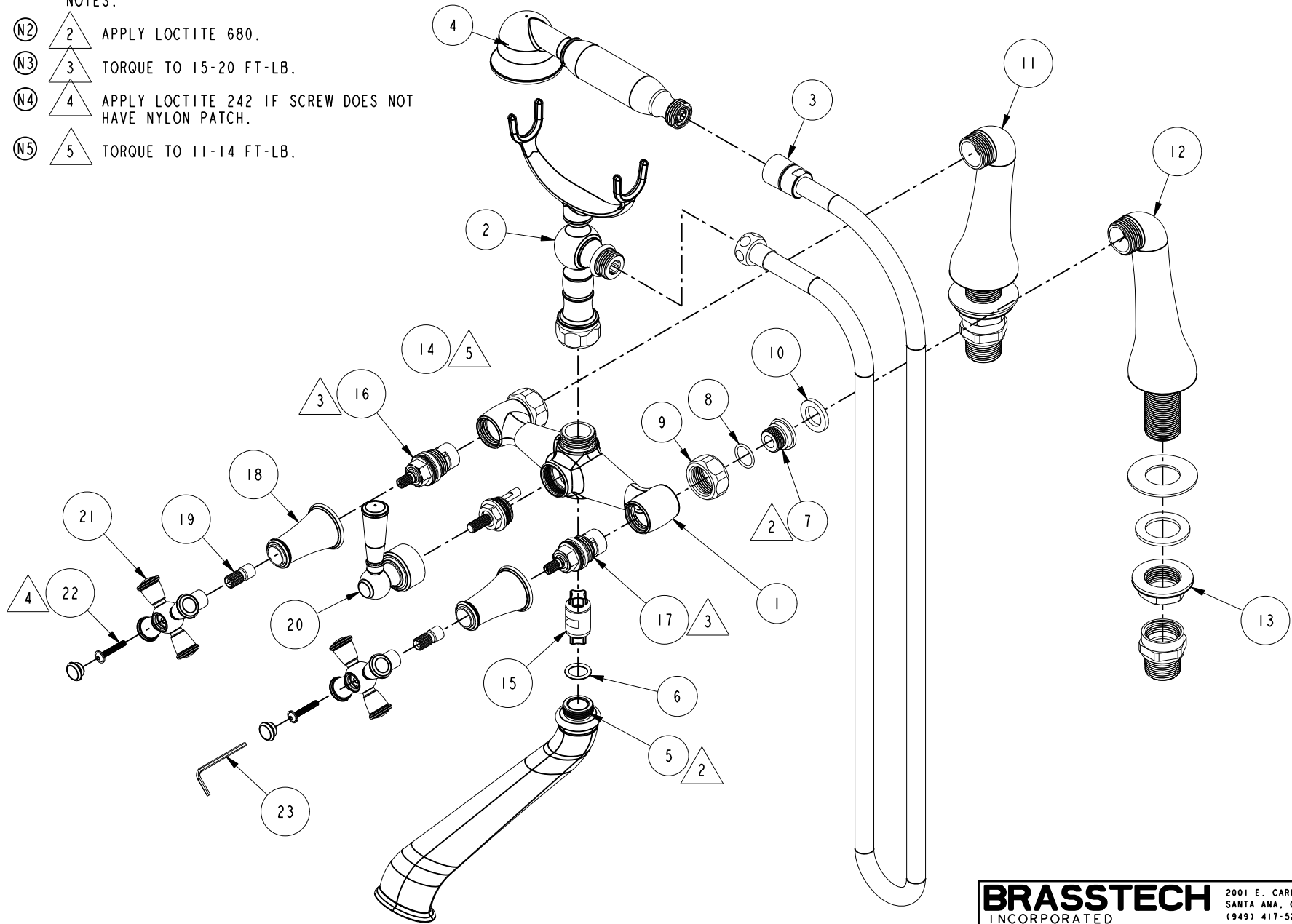

BRASSTECH		2001 E. CARNEGIE AVE. SANTA ANA, CA 92705 (949) 417-5207	
INCORPORATED			
DWG NO.	2400-4272		REV C
SCALE .250	REF. -	SHEET 2 OF 3	

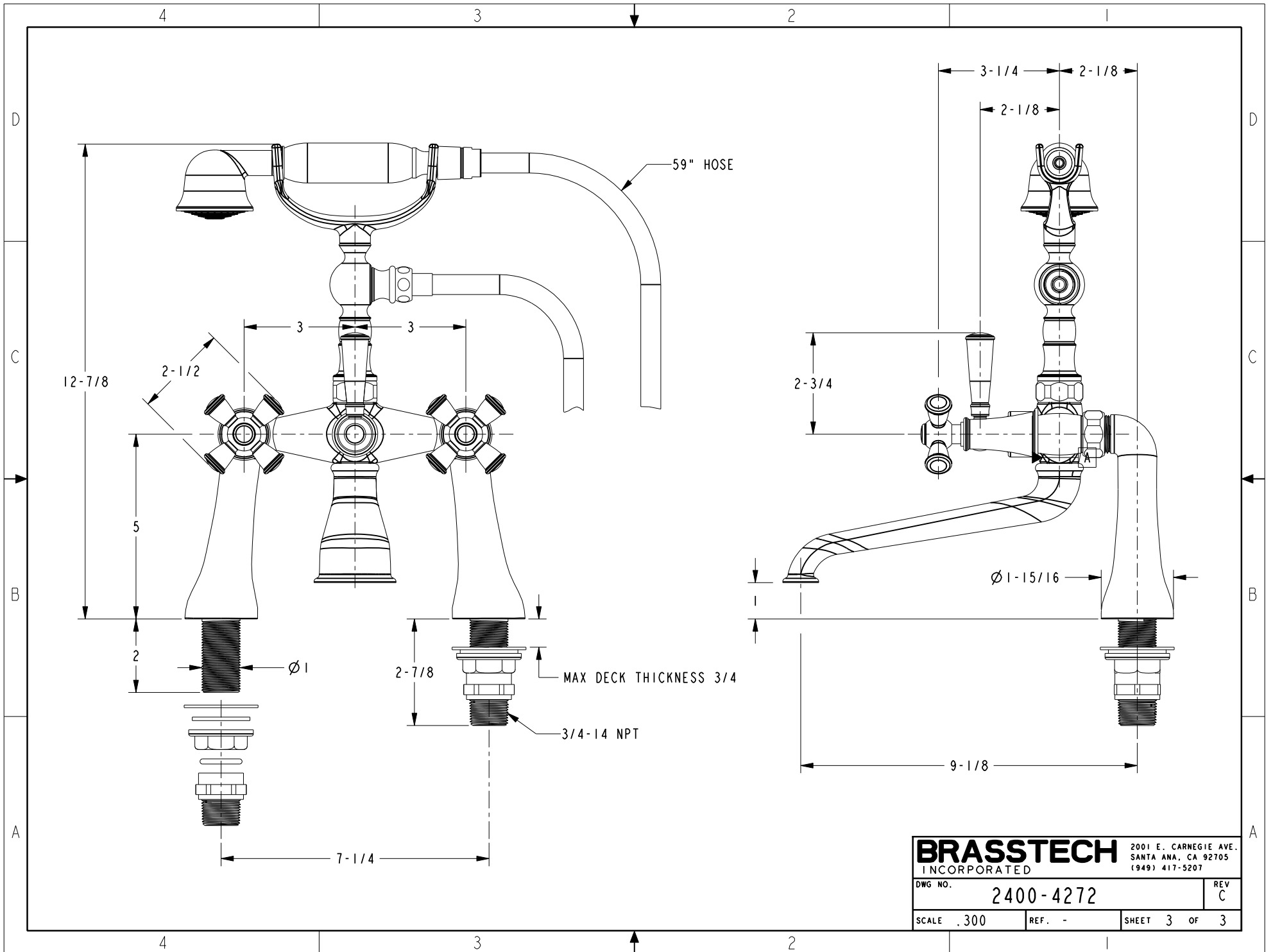

BRASSTECH		2001 E. CARNEGIE AVE.	
INCORPORATED		SANTA ANA, CA 92705	
DWG NO.		REV	
2400-4272		C	
SCALE .300	REF. -	SHEET 3	OF 3