

- EN** Installation / User Instructions / Warranty
- FR** Instructions de montage / Mode d'emploi / Garantie
- ES** Instrucciones de montaje / Manejo / Garantía

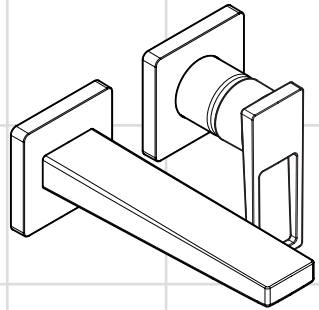

Metropol
74526xx1

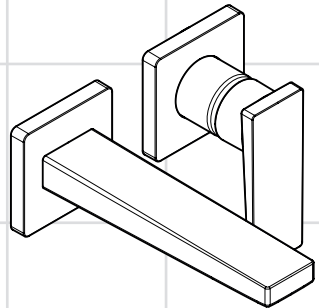

Metropol
32526xx1

Technical Information

Water pressure	
Recommended	15 - 75 PSI (0.1 - 0.5 MPa)
Maximum	145 PSI (1 MPa)
Hot water temp.	
Recommended	120°-140° F (48° -60° C)*
Maximum	158° F (70° C)*
Max. flow rate	1.2 GPM (4.5 L/min)

- * Please know and follow all applicable local plumbing codes when setting the temperature on the water heater.

Installation Considerations

- For best results, Hansgrohe recommends that this unit be installed by a licensed, professional plumber.
- Please read over these instructions thoroughly before beginning installation. Make sure that you have all tools and supplies needed to complete the installation.
- This trim is for use with rough valve model 13622181 (not included).
- Keep this booklet and the receipt (or other proof of date and place of purchase) for this product in a safe place. The receipt is required should it be necessary to request warranty parts.

Données techniques

Pression d'eau	
recommandée	15 - 75 PSI (0.1 - 0.5 MPa)
maximum	145 PSI /10 Bar
Température d'eau chaude	
recommandée	120°-140° F (48° -60° C)*
maximum	158° F (70° C)*
Capacité nominale	1.2 GPM (4.5 L/min)

- * Vous devez connaître et respecter tous les codes de plomberie locaux applicables pour le réglage de la température du chauffe-eau.

À prendre en considération pour l'installation

- Pour de meilleurs résultats, Hansgrohe recommande que ce produit soit installé par un plombier professionnel licencié.
- Veuillez lire attentivement ces instructions avant de procéder à l'installation. Assurez-vous de disposer de tous les outils et du matériel nécessaires pour l'installation.
- Ce dispositif requiert une pièce intérieure 13622181.
- Conservez ce livret et le reçu (ou une autre preuve sur laquelle figurent la date et l'endroit de l'achat) pour ce produit dans un endroit sûr. Le reçu est requis si vous commandez des pièces sous garantie.

Datos técnicos

Presión en servicio recomendada max.	15 - 75 PSI (0.1 - 0.5 MPa) 145 PSI (1 MPa)
Temperatura del agua caliente recomendada max.	120°-140° F (48° -60° C)* 158° F (70° C)*
Caudal máximo	1.2 GPM (4.5 L/min)

* Debe conocer y cumplir todos los códigos locales aplicables para ajustar la temperatura del calentador de agua.

Consideraciones para la instalación

- Para obtener mejores resultados, la instalación debe estar a cargo de un plomero profesional matriculado.
- Antes de comenzar la instalación, lea estas instrucciones detenidamente. Asegúrese de tener las herramientas y los insumos necesarios para completar la instalación.
- La unidad requiere una pieza interior de válvula 13622181.
- Mantenga este folleto y el recibo (u otro comprobante del lugar y fecha de compra) de este producto en lugar seguro. El recibo se requiere en caso de ser necesario solicitar piezas bajo garantía.

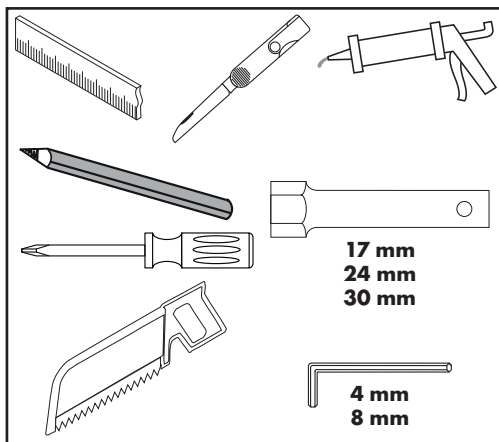
**Tools Required / Outils Utiles /
Herramientas Útiles**

Metropol
32526xx1

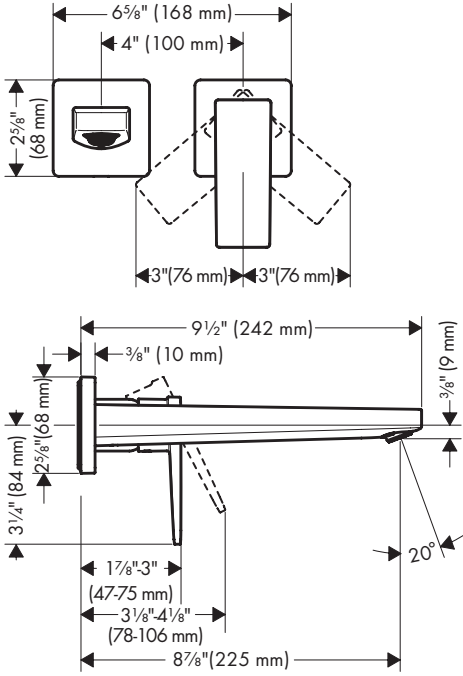

Metropol
74526xx1

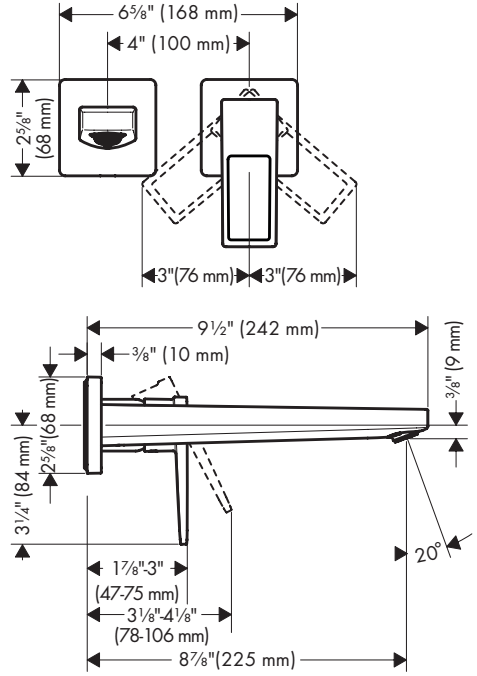

Installation Suggestions / Suggestions d'installation / Sugerencias para la instalación

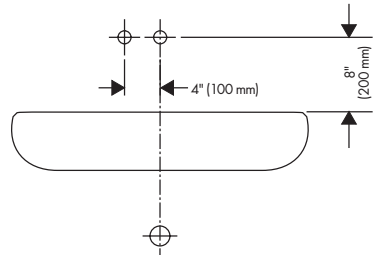
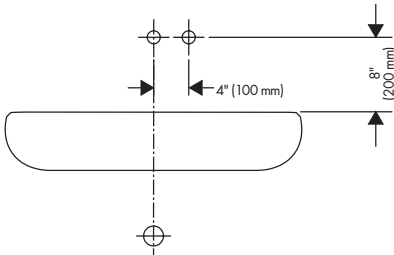
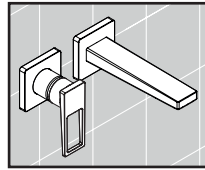
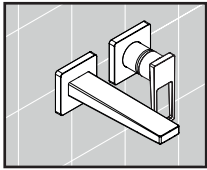

Installation / Installation / Instalación

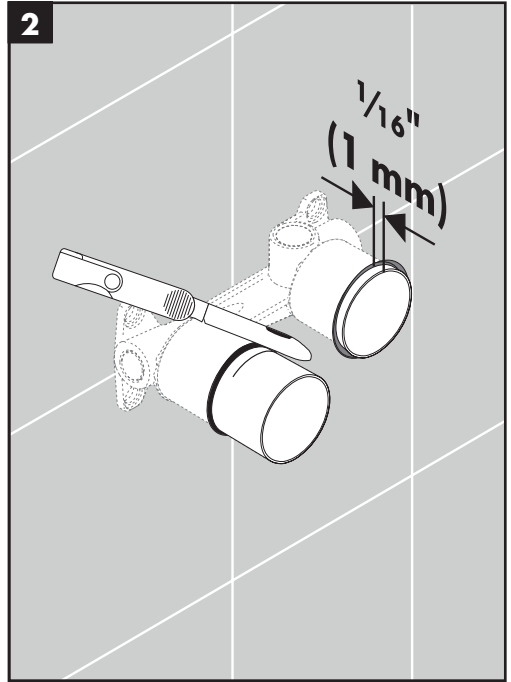
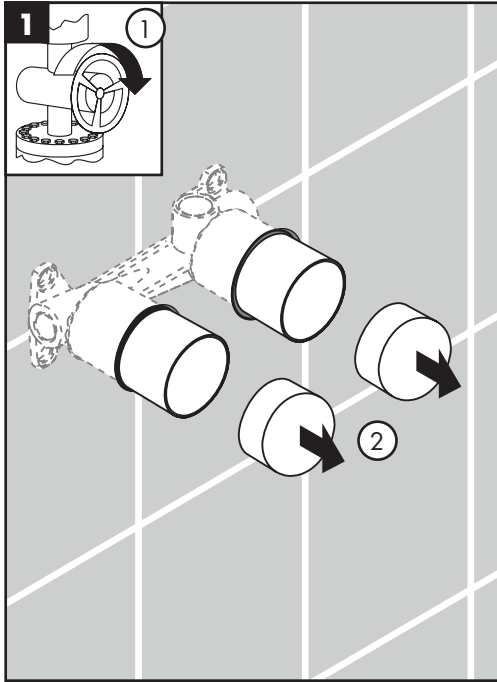

English

Turn the water off at the main before beginning.

Remove the covers.

Cut the plaster shields so that they extend $\frac{1}{16}$ " (1 mm) outside the surface of the finished wall.

Français

Fermez l'eau à la valve principale avant de commencer.

Retirez les couvercles.

Coupez les protecteurs de façon à ce qu'une partie de ceux-ci $\frac{1}{16}$ po (1 mm) soit à l'extérieur de la surface du mur fini.

Español

Cierre el paso del agua en la entrada del suministro antes de comenzar.

Retire las tapas.

Corte los protectores de yeso de modo que sobresalgan $\frac{1}{16}$ " (1 mm) de la superficie de la pared terminada.

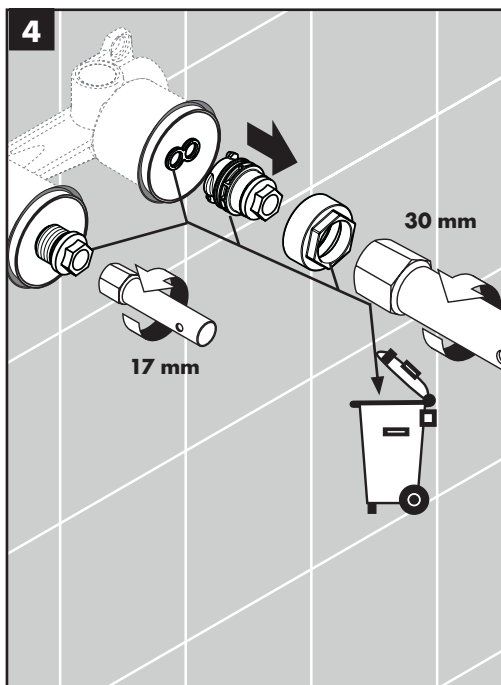
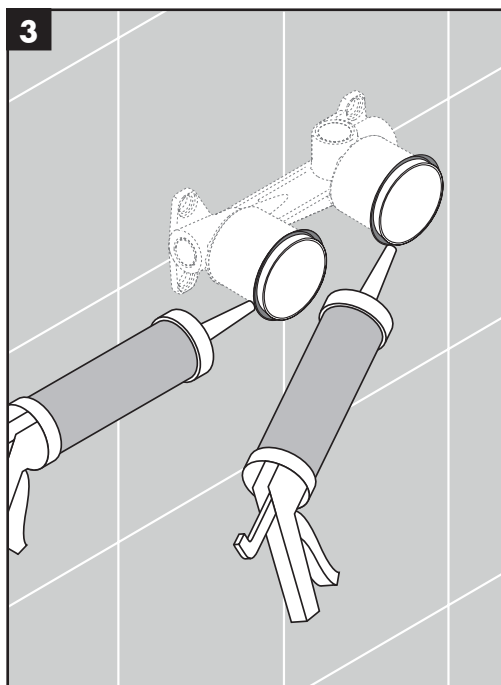

English

⚠ Seal the wall around the plaster shields using waterproof sealant.

⚠ Failure to seal the wall can lead to possible water damage.

Remove the plug from the spout port.

Remove the nut, flush housing, and sealing ring from the cartridge port.

Français

⚠ Scellez le mur autour des protecteurs à l'aide d'un agent d'étanchéité.

⚠ Si le mur n'est pas scellé, l'eau pourrait éventuellement causer des dommages.

Retirez le bouchon du port du bec de remplissage.

Retirez l'écrou, le compartiment affleurant et la bague d'étanchéité du port de cartouche.

Español

⚠ Selle la pared alrededor de los protectores de yeso con un sellador impermeable.

⚠ Si no se sella la pared, pueden producirse daños por acción del agua.

Retire el tapón del orificio del surtidor.

Retire la tuerca, el alojamiento de descarga y el anillo de sellado del orificio del cartucho.

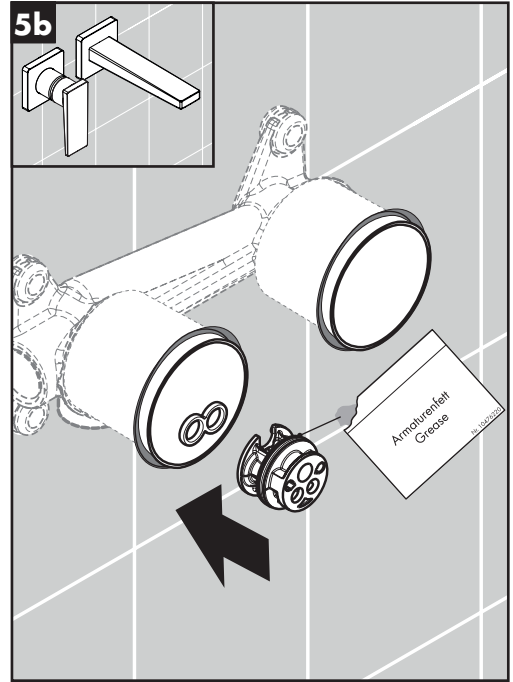
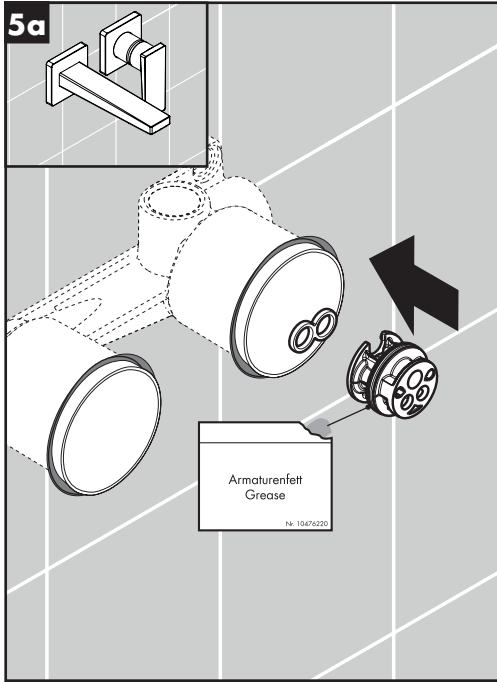

English

Lightly grease the o-ring on the cartridge adapter.

Install the adapter in the cartridge port of the rough.

Français

Graissez légèrement le joint torique de l'adaptateur de cartouche.

Installez l'adaptateur dans le côté de la poignée de la pièce intérieure.

Español

Lubrique levemente el retén anular en el adaptador del cartucho.

Instale el adaptador del lado de la manija de la pieza interior.

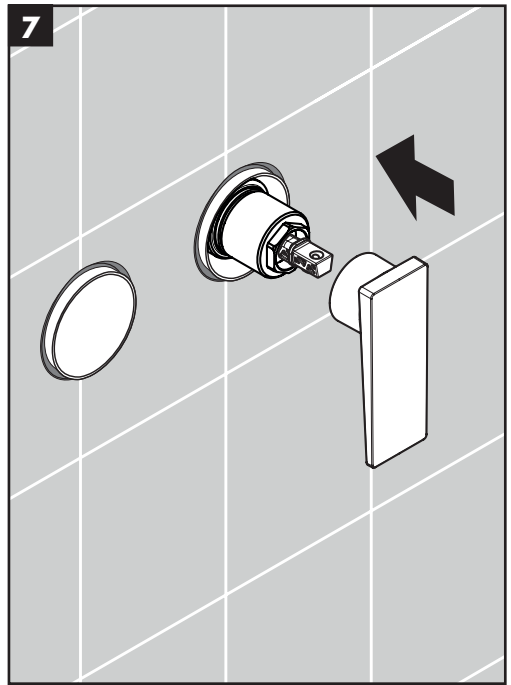
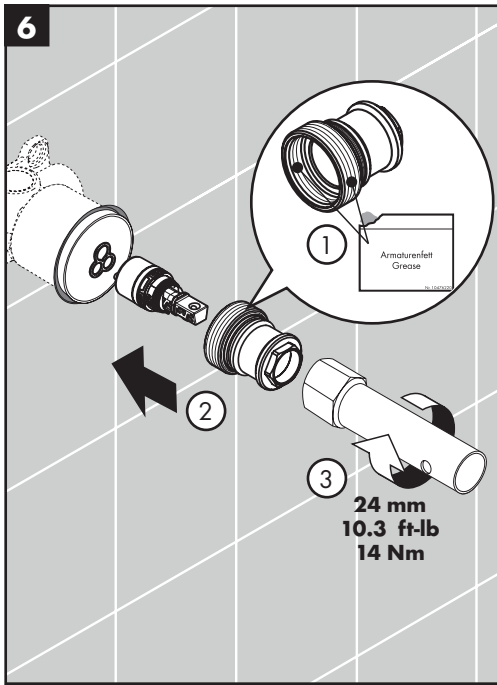

English

Lightly lubricate the threads on the nut.
Install the cartridge and the nut.

Temporarily install the handle.

Français

Installez l'écrou de serrage sur le côté de la poignée de la pièce intérieure.
Installez la cartouche et l'écrou.

Installez la poignée temporairement.

Español

Instale la tuerca de sujeción del lado de la manija de la pieza interior.
Instale el cartucho y la tuerca.

Instale la manija temporalmente.

8

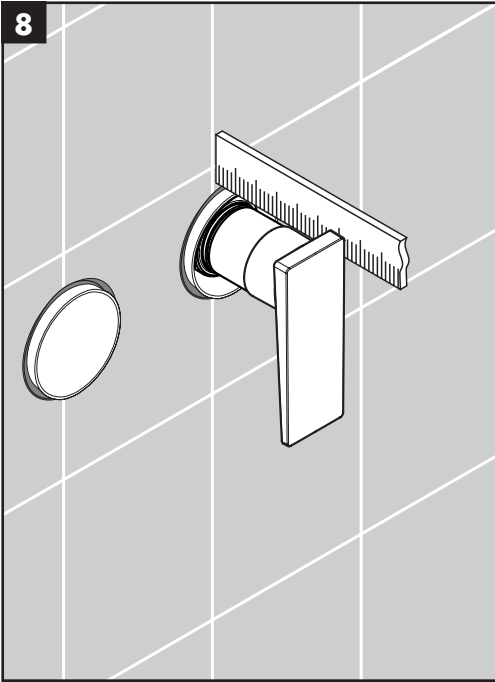

English

Measure the distance between the wall and the top of the handle.

Français

Mesurez la distance entre le mur et l'extrémité de la poignée.

Español

Mida la distancia entre la pared y el borde de la manija.

9

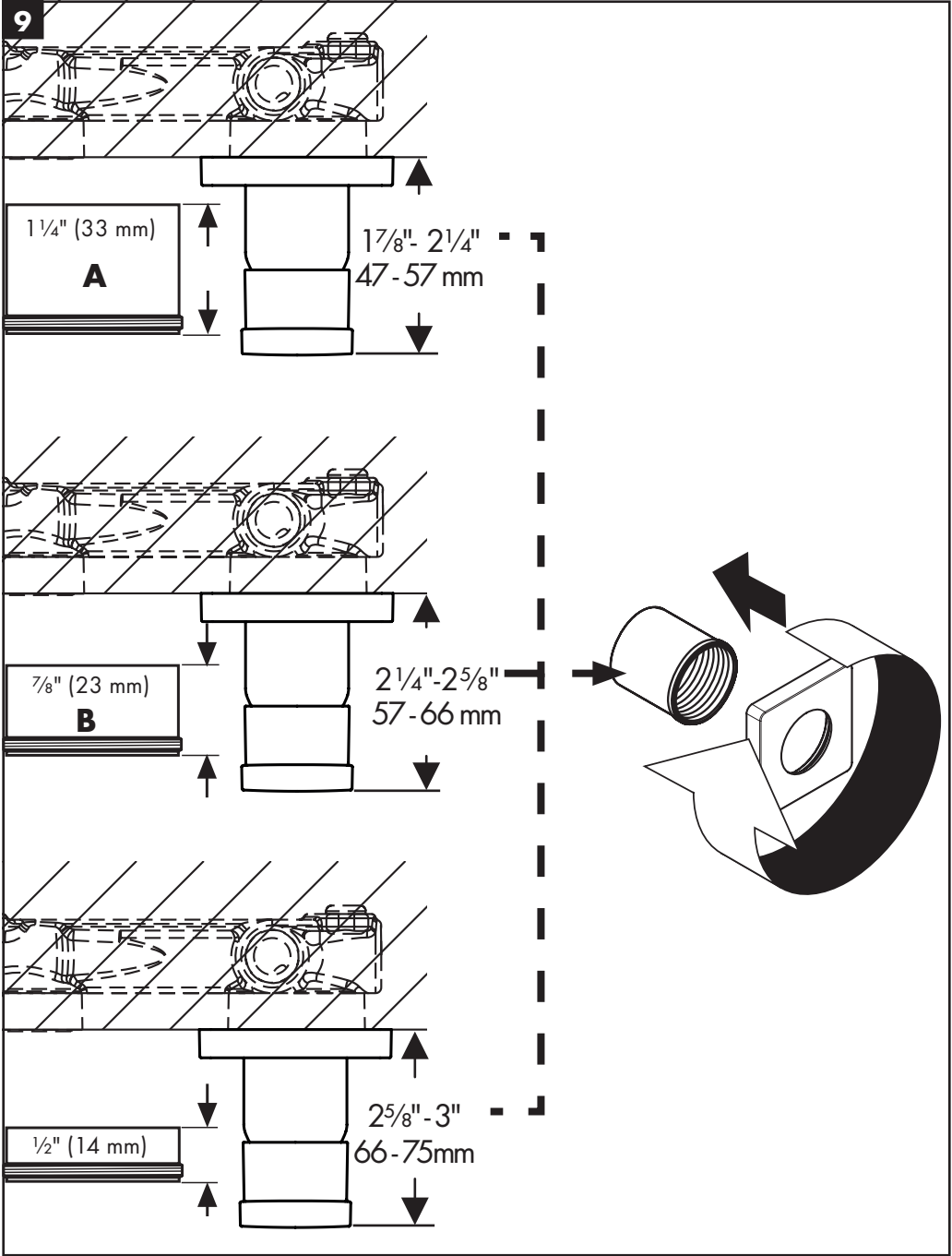

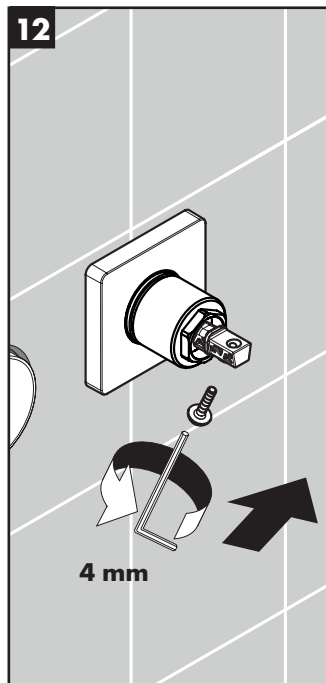
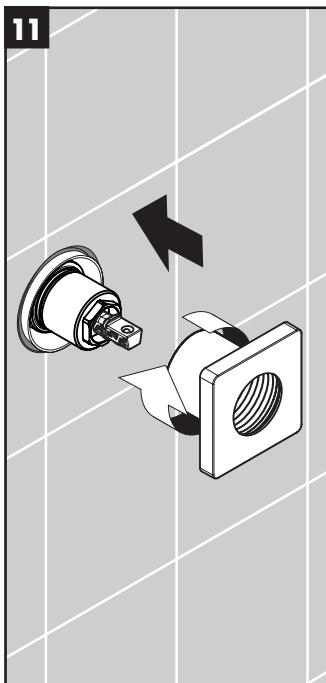
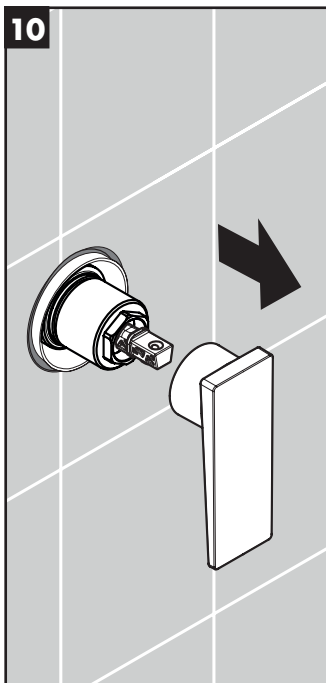

English

Select the appropriate sleeve.

Connect the sleeve to the escutcheon.

Remove the handle.

Install the sleeve/escutcheon assembly over the cartridge.

Install the handle screw on the cartridge stem.

Français

Choisissez la gaine appropriée.

Raccordez la gaine au écusson.

Retirez la poignée.

Installez l'ensemble gaine/écusson avec l'ouverture large au-dessus de la cartouche.

Installez la vis de la poignée.

Español

Seleccione el manguito apropiado.

Conecte el manguito al escudo.

Retire la manija.

Instale el conjunto del escudo/manguito con la abertura grande sobre el cartucho.

Instale el tornillo de la manija.

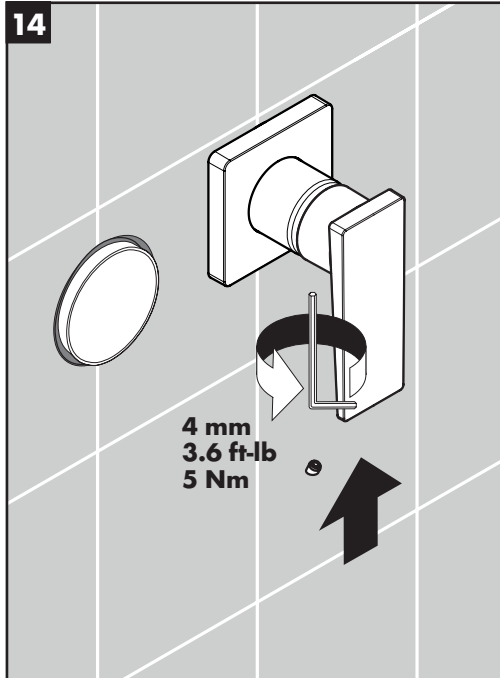
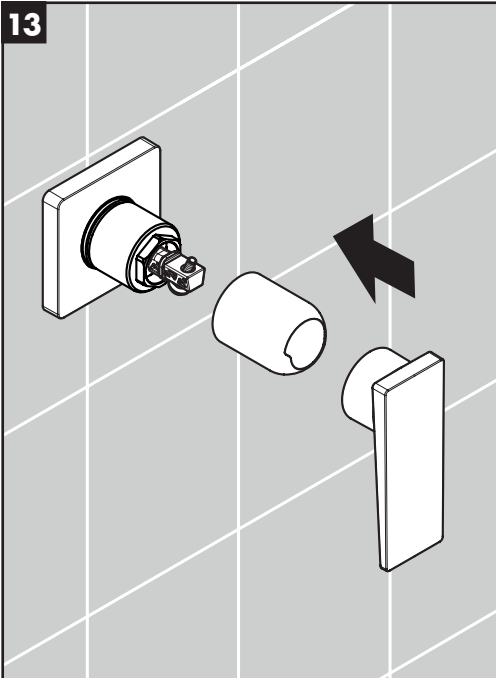

English

Français

Español

Install the sleeve and the handle.

Installez la bride et la poignée.

Instale la brida y la manija.

Tighten the handle screw.

Serrez la vis.

Ajuste el tornillo.

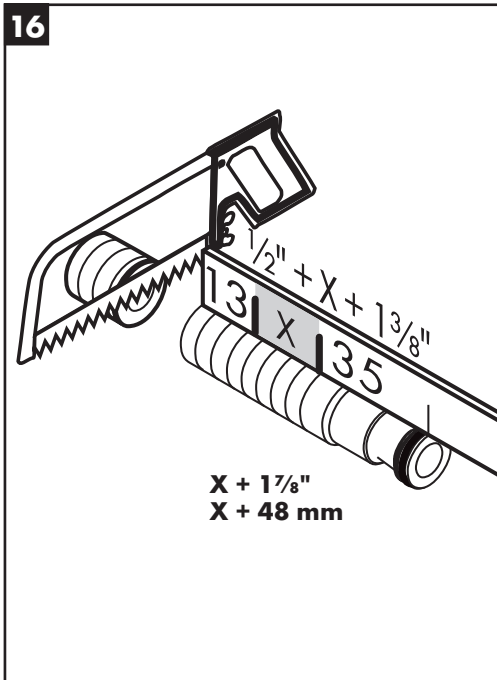
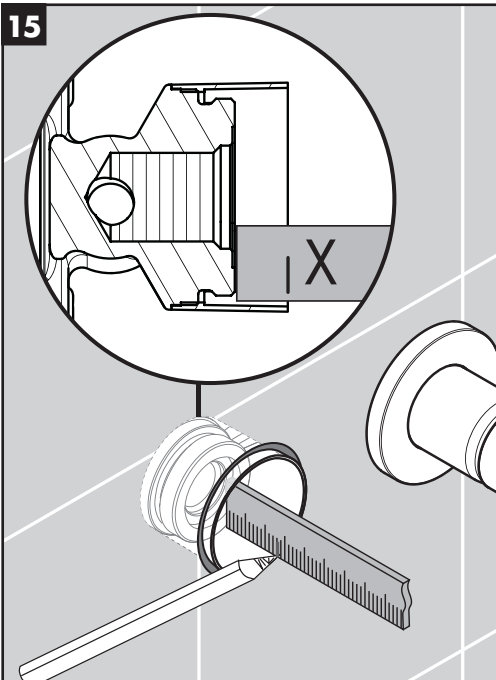

English

Measure the distance from the surface of the spout port rough to the outside edge of the plaster shield ("X").

Cut the threaded portion of the spout so that it is $X + 1\frac{7}{8}$ " ($X + 48$ mm) long.

Français

Mesurez la distance entre la surface de la pièce intérieure du port du bec de remplissage et le rebord extérieur du protecteur (« X »).

Coupez la raccord fileté du bec de façon à ce que sa longueur corresponde à $X + 1\frac{7}{8}$ po ($X + 48$ mm) .

Español

Mida la distancia desde la superficie de la pieza interior del orificio del surtidor hasta el borde externo del protector de yeso ("X").

Corte la parte roscada del surtidor de modo que tenga el largo $X + 1\frac{7}{8}$ " ($X + 48$ mm) .

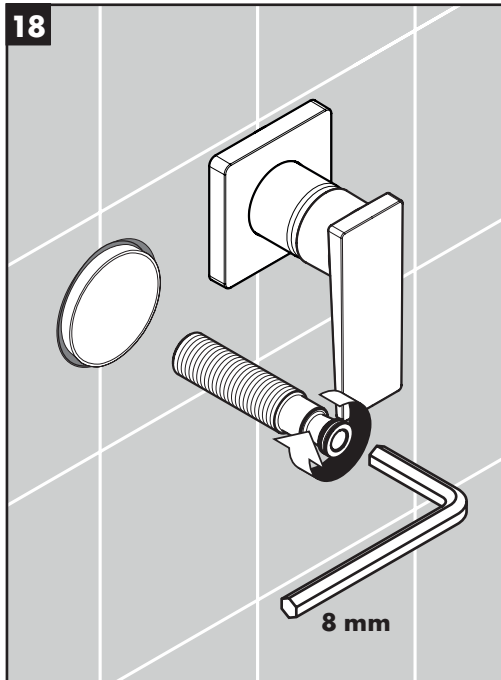
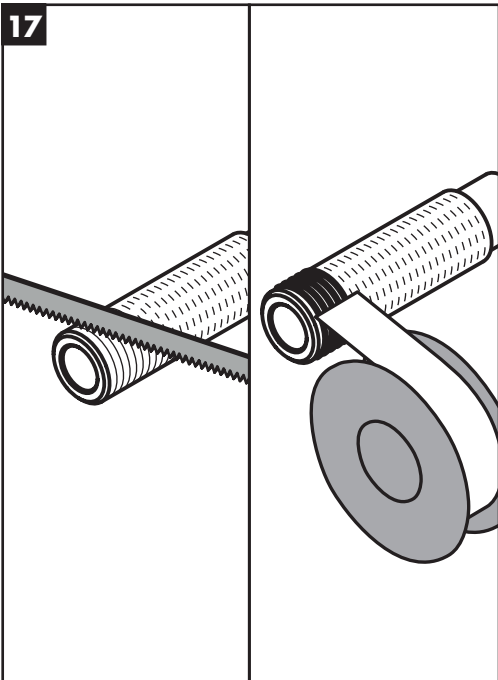

English

Use a file or saw to lightly roughen the threads on the connecting thread.

Wrap the threads with several layers of plumbers' tape.

Install the connecting thread in the rough.

Français

Coupez toute la raccord fileté du bec.

Enroulez du ruban de plomberie autour des filets du bec.

Installez la raccord fileté dans la pièce intérieure.

Español

Lime todas las roscas en la parte roscada.

Envuelva las roscas con cinta de plomero.

Instale la parte roscada en la pieza interior

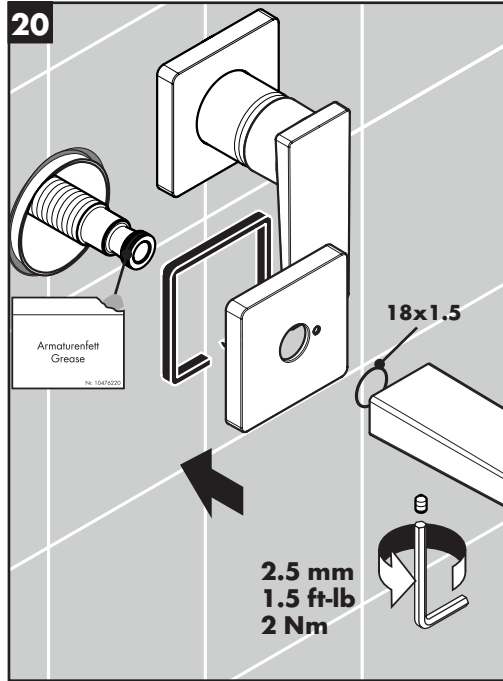
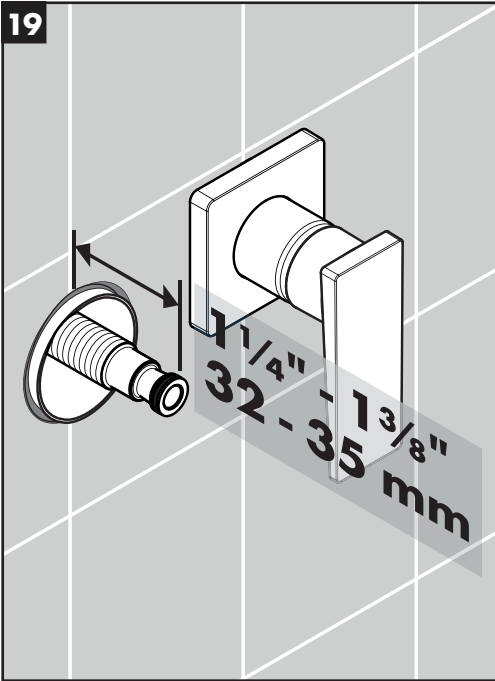

English

The connecting thread should extend $1\frac{1}{4}$ "- $1\frac{3}{8}$ " (32 - 35 mm) outside the surface of the finished wall.

Lightly lubricate the o-ring on the connection thread.

Install the escutcheon and the spout.

Tighten the spout screw.

Français

La raccord fileté doit être installé de façon à ce qu'une partie de $1\frac{1}{4}$ po po à $1\frac{3}{8}$ po (32 - 35 mm) soit à l'extérieur du mur fini.

Lubrifiez légèrement le joint torique sur la raccord fileté.

Installez l'écusson et la bec.

Serrez la vis.

Español

La parte roscada debe extenderse $1\frac{1}{4}$ "- $1\frac{3}{8}$ " (32 - 35 mm) fuera de la pared acabada.

Lubrique levemente la junta toroidal en la parte roscada.

Instale el escudo y el surtidor.

Ajuste el tornillo.

21

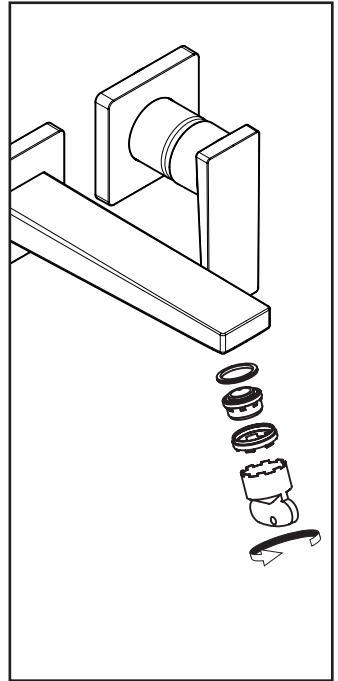
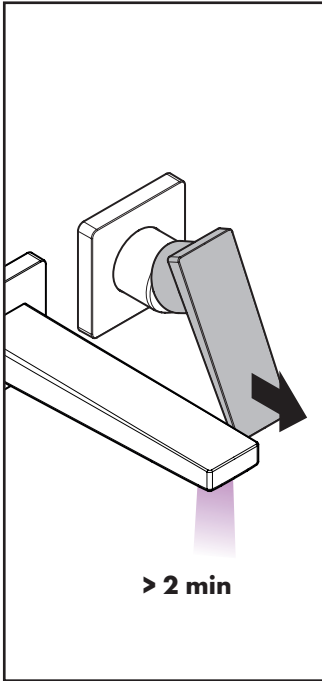
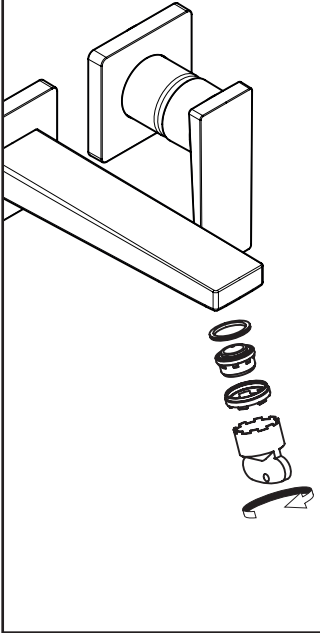

English

Remove the aerator.

Flush the lines for at least two minutes.

Reinstall the aerator.

Français

Retirez l'aérateur.

Rincez le robinet pendant au moins deux minutes.

Réinstallez l'aérateur

Español

Retire el aireador.

Purgue el grifo durante al menos dos minutos.

Reinstale el aireador.

Set the high temperature limit stop / Réglage de la butée limite d'eau chaude / Ajuste el tope de limite de alta temperatura

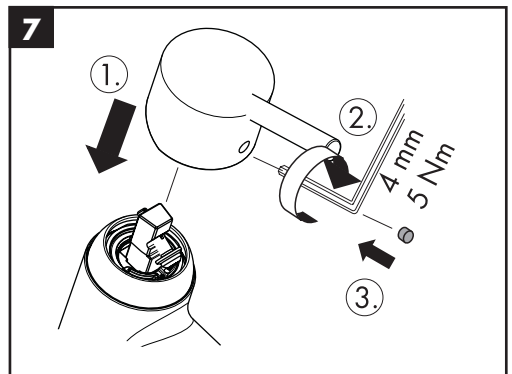
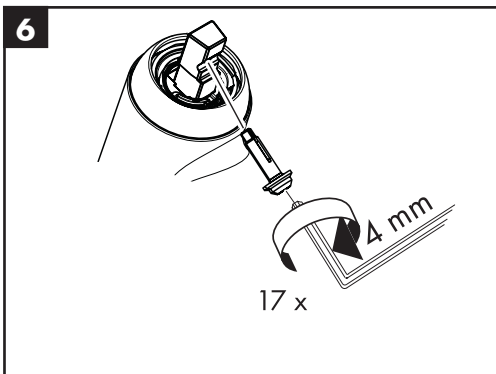
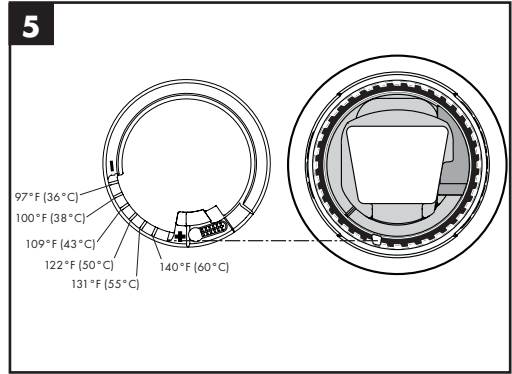
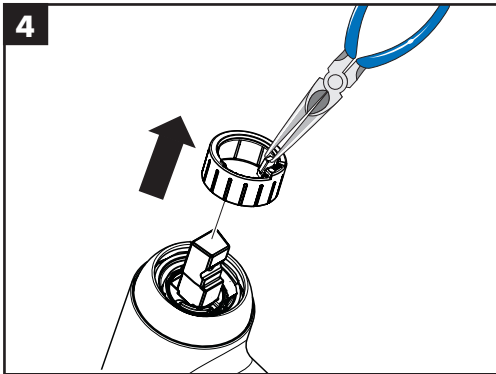
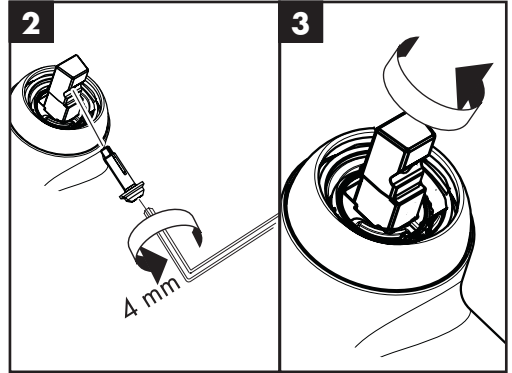
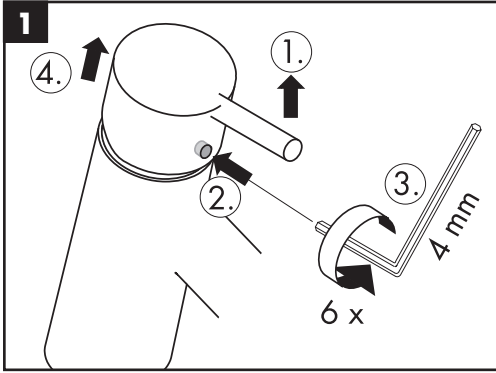
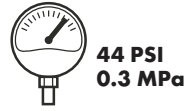
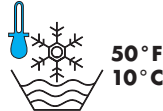
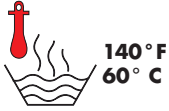

Replacement Parts / Pièces détachées / Repuestos

Metropol

32526xx1 / 74526xx1

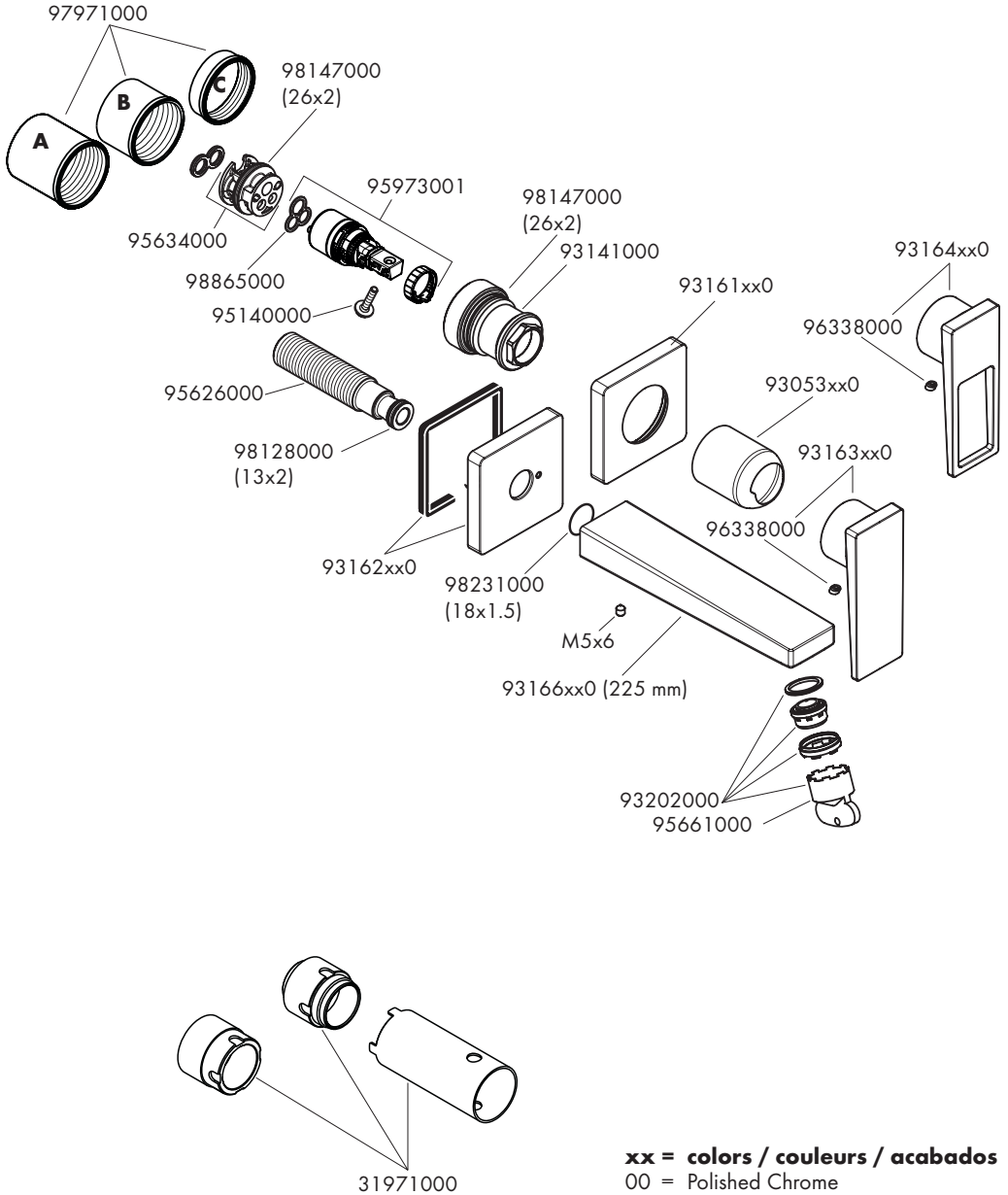

xx = colors / couleurs / acabados
 00 = Polished Chrome
 82 = Brushed Nickel

User Instructions / Instructions de service / Manejo

on
ouvert
abierto

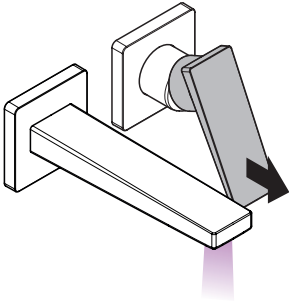

off
fermé
cerrar

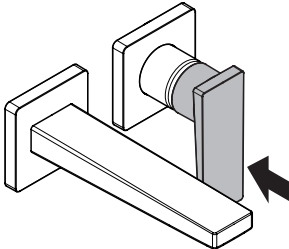

cold
froid
frío

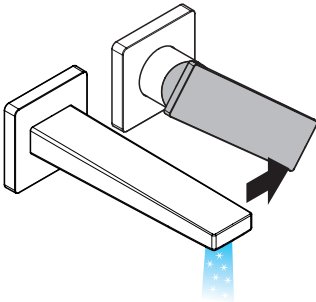

hot
chaud
caliente

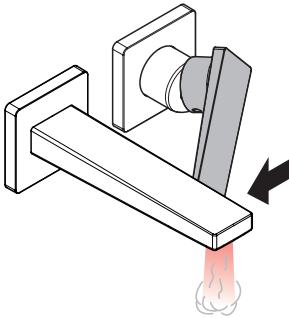

Cleaning Recommendation for Hansgrohe Products

Modern bathroom faucets, kitchen faucets and shower products are made from different materials to comply with the needs of the market with regard to design and functionality. To avoid damage to the product, it is necessary to take proper care of it.

For best results:

- Prevent the buildup of mineral scale and /or soap residue by cleaning your Hansgrohe product(s) when needed.
- Select a cleaning agent specifically intended for the type of product.
- **Do not** use these types of cleaners as they will cause damage to your Hansgrohe product:
 - ✘ Any cleaning agent containing hydrochloric acid, formic acid, lye, or acetic acid.
 - ✘ Abrasive cleaning powders, pads, or brushes.
 - ✘ Steam cleaners.
 - ✘ “No rinse” cleaning agents.
- **Always** follow the instructions provided by the manufacturer of the cleaning agent.
- **Do not** mix cleaning agents, unless directed by the manufacturer.
- **Do not** spray cleaners directly onto the product as drops could enter openings and gaps and cause damage. When using spray cleaners, spray the cleaner onto a soft cloth or sponge.
- **Always** rinse your Hansgrohe product thoroughly with clear water and polish dry with a soft cloth after cleaning.

Important

- Residue from soaps and shampoos can cause damage. Rinse the product with clean water after each use.
- Residue from basin/tub/tile cleaner can cause damage to faucets and fittings. Immediately rinse any overspray from the Hansgrohe product.
- **Damage to the product caused by improper care or the use of improper cleaning agents is not covered by the warranty.**
- **If a component of the product is damaged, replace it, as there is risk of injury.**

Conseil de nettoyage pour les produits Hansgrohe

Les robinets pour les salles de bains et les cuisines modernes ainsi que les produits récents pour les douches se composent de matériaux différents afin de satisfaire aux besoins du marché en termes de conception et de fonctionnalité. Afin d'éviter d'endommager le produit, il est nécessaire d'en prendre soin.

Pour de meilleurs résultats :

- Empêchez l'accumulation de tarte et/ou de résidu de savon en nettoyant votre produit Hansgrohe lorsque c'est nécessaire.
- Sélectionnez un produit de nettoyage spécifiquement prévu pour ce type de produit.
- **N'utilisez pas** ces types de nettoyants car ils peuvent endommager votre produit Hansgrohe :
 - ✘ Tout produit de nettoyage contenant de l'acide chlorhydrique, de l'acide formique, de la potasse ou de l'acide acétique.
 - ✘ Les poudres de nettoyage, les tampons ou les brosses abrasives.
 - ✘ Les nettoyeurs à vapeur.
 - ✘ Les produits de nettoyage « sans rinçage ».
- **Ne mélangez pas** les produits de nettoyage, à moins que cela soit indiqué par le fabricant.
- **Ne pulvérisez pas** les nettoyants directement sur le produit car des gouttes pourraient entrer dans les ouvertures et les fentes et causer des dommages. Lorsque vous utilisez des nettoyants par pulvérisation, pulvériser le nettoyant sur un chiffon ou une éponge douce.

-
- Après le nettoyage rincer abondamment à l'eau claire pour éliminer intégralement les restes de détergent.

Important

- Les résidus de produits pour le corps comme les savons liquides, shampoings, gels de douche, teintures pour cheveux, parfums, après-rasage et vernis à ongles peuvent causer des détériorations. Rincez le produit avec de l'eau propre après chaque utilisation.
- Le résidu provenant des nettoyants pour cuvette/baignoire/carrelage peut endommager les robinets et les raccords de tuyauterie. Rincez immédiatement toute surpulvérisation sur le produit Hansgrohe.
- De même, il est interdit de stocker des détergents ou des produits chimiques sous les produits, par ex. dans un meuble sous lavabo, car les vapeurs qui s'en dégagent risquent d'abîmer les produits.
- **Les dommages au produit causés par un mauvais entretien ou par l'utilisation de produits de nettoyage inadéquats ne sont pas couverts par la garantie.**
- **Si un composant du produit est endommagé, remplacez-le, car il existe un risque de blessure.**

Recomendación de limpieza para los productos de Hansgrohe

Hoy en día, las griferías de baño y de cocina así como duchas modernas se componen de materiales muy distintos para satisfacer las exigencias del mercado respecto al diseño y la funcionalidad. Para evitar daños y reclamaciones hay que tener en cuenta ciertos aspectos tanto en el uso como en su limpieza.

Para obtener mejores resultados:

- Evite la acumulación de restos de jabón o sarro limpiando el producto Hansgrohe cuando sea necesario.
- Seleccione un agente de limpieza diseñado específicamente para el tipo de producto.
- **No use** estos tipos de limpiadores, ya que causarán daño a su producto Hansgrohe:
 - ✗ Agentes limpiadores que contengan ácido clorhídrico, fórmico, acético o lejía.
 - ✗ Polvos, paños o cepillos de limpieza abrasivos.
 - ✗ Limpiadores a vapor
 - ✗ Agentes de limpieza "sin enjuague".
- **Siempre** siga las instrucciones provistas por el fabricante del agente de limpieza.
- **No mezcle** los agentes de limpieza, a menos que esté indicado por el fabricante.
- **No rocíe** limpiadores directamente sobre el producto, ya que podrían caer gotas sobre las aberturas y espacios y causar daños. Cuando use limpiadores en spray, rocíe el limpiador sobre un paño suave o esponja.
- **Siempre** enjuague su producto Hansgrohe con agua limpia y séquelo y lustrelo con un paño suave después de la limpieza.

Importante

- Los residuos de productos de aseo como jabón líquido, champú, gel de ducha, tintes de pelo, perfumes, lociones de afeitado y esmalte de uñas pueden dañar también los materiales. Enjuague el producto con agua limpia después de cada uso.
- Los residuos de limpiadores para lavatorios, bañeras o azulejos pueden causar daño a los grifos y accesorios. Enjuague inmediatamente cualquier derrame que haya sobre el producto de Hansgrohe.
- Tampoco pueden generarse depósitos de productos de limpieza o químicos debajo de los productos, p. ej. En un armario de lavabo. De lo contrario, los vapores generados pueden dañar los productos.
- **Los daños que resulten de un cuidado inadecuado o uso de agentes de limpieza inadecuados no están cubiertos por la garantía.**
- **Si se daña un componente del producto, reemplácelo, ya que existe riesgo de lesión.**

Limited Consumer Warranty

This warranty is limited to products manufactured by Hansgrohe, Inc. ("Hansgrohe") that are purchased by a consumer in the United States or Canada after March 1, 1996, and installed in either the United States or in Canada.

WHO IS COVERED BY THE WARRANTY

This limited warranty extends to the original purchaser only. This warranty is non-transferable. Hansgrohe neither assumes nor authorizes any person to create for it any other obligation or liability in connection with this product.

LENGTH OF WARRANTY

If you are a consumer who purchased the product for use primarily for personal, family or household purposes, this limited warranty starts on the date of purchase and extends for as long as you own the product and the home in which the product is originally installed. If you purchased the product for use primarily for any other purpose, including, without limitation, a commercial purpose, this limited warranty starts on the date of purchase and extends (i) for 1 year, with respect to Hansgrohe and Commercial products, and (ii) for 5 years, with respect to Axor products. The Rubbed Bronze finish is subject to a 3-year limited warranty starting on the date of purchase.

WHAT IS COVERED BY THE WARRANTY

This limited warranty covers only your Hansgrohe manufactured product. Hansgrohe warrants this product against defects in material or workmanship as follows:

Hansgrohe will replace at no charge for parts only or, at its option, replace any product or part of the product that proves defective because of improper workmanship and/or material, under normal installation, use, service and maintenance. If Hansgrohe is unable to provide a replacement and repair is not practical or cannot be made in timely fashion, Hansgrohe may elect to refund the purchase price in exchange for the return of the product. REPAIR OR REPLACEMENT (OR, IN LIMITED CIRCUMSTANCES, REFUND OF THE PURCHASE PRICE) AS PROVIDED UNDER THIS LIMITED WARRANTY IS THE EXCLUSIVE REMEDY OF THE PURCHASER.

WHAT IS NOT COVERED BY THE WARRANTY

- A. Conditions, malfunctions or damage not resulting from defects in material or workmanship.
- B. Conditions, malfunctions or damage resulting from (1) normal wear and tear, improper installation, improper maintenance, misuse, abuse, negligence, accident or alteration; (2) the use of abrasive or caustic cleaning agents or "no-rinse" cleaning products, or the use of the product in any manner contrary to the product instructions; or (3) conditions in the home such as excessive water pressure or corrosion.

- C. Labor and other expenses for disconnection, deinstallation, or return of the product for warranty service (including but not limited to proper packaging and shipping costs), or for installation or reinstallation of the product.
- D. Accessories, connected materials and products, or related products not manufactured by Hansgrohe.
- E. Any Hansgrohe or Axor product sold for display purposes.

HANSGROHE SHALL NOT BE LIABLE TO PURCHASER OR ANY OTHER PERSON FOR ANY INCIDENTAL, SPECIAL OR CONSEQUENTIAL DAMAGES, ARISING OUT OF BREACH OF THIS LIMITED WARRANTY.

Some provinces and some states do not allow the exclusion or limitation of incidental or consequential damages, so the above limitation or exclusion may not apply to you.

TO OBTAIN WARRANTY PARTS OR INFORMATION

Contact your Hansgrohe retailer, or contact Technical Service at:

Hansgrohe, Inc.
1492 Bluegrass Lakes Parkway
Alpharetta, GA 30004
Toll-free 800-334-0455

In requesting warranty service, you will need to provide:

1. The sales receipt or other evidence of the date and place of purchase.
2. A description of the problem.
3. Delivery of the product or the defective part, postage prepaid and carefully packed and insured, to:

Hansgrohe, Inc.
1492 Bluegrass Lakes Parkway
Alpharetta, GA 30004
Toll-free 800-334-0455

When warranty service is completed, any repaired or replacement product or part will be returned to you postage prepaid. REVISED MAY 1, 2016.

PRODUCT INSTRUCTIONS AND QUESTIONS

Upon purchase or prior to installation, please carefully inspect your Hansgrohe product for any damage or visible defect. Prior to installing, always carefully study the enclosed instructions on the proper installation and the care and maintenance of this product. If you have questions at any time about the use, installation or performance of your Hansgrohe product, or this warranty, please write us or call us toll-free at 800-334-0455.

hansgrohe

Hansgrohe, Inc. 1490 Bluegrass Lakes Parkway Alpharetta, GA 30004
Tel. 800-334-0455 Fax 770-889-1783

www.hansgrohe-usa.com