

# AXOR®

hansgrohe

**EN** Installation / User Instructions / Warranty  
**FR** Instructions de montage / Mode d'emploi / Garantie  
**ES** Instrucciones de montaje / Manejo / Garantía

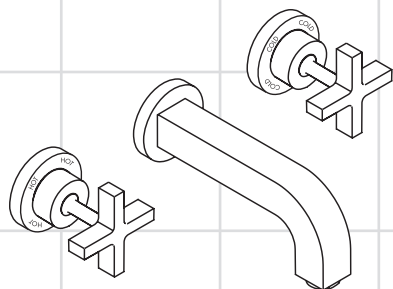

**Citerio**  
39143xx1

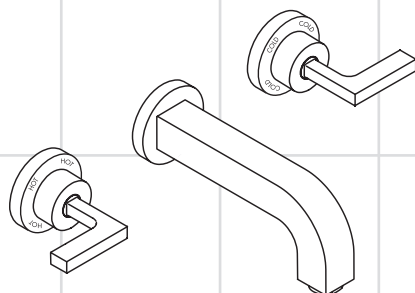

**Citerio**  
39147xx1

**Technical Information**

Recommended water pressure	15 - 75 PSI
Max. water pressure	145 PSI
Recommended hot water temp.	120° - 140° F*
Max. hot water temp	176° F*
Flow rate	1.2 GPM

\*Please know and follow all applicable local plumbing codes when setting the temperature on the water heater.

**Installation Considerations**

- For best results, Hansgrohe recommends that this unit be installed by a licensed, professional plumber.
- Please read over these instructions thoroughly before beginning installation. Make sure that you have all tools and supplies needed to complete the installation.
- This trim is for use with rough valve 10303181 (not included).
- Keep this booklet and the receipt (or other proof of date and place of purchase) for this product in a safe place. The receipt is required should it be necessary to request warranty parts.

**Données techniques**

Pression d'eau recommandée	15 - 75 PSI
Pression d'eau maximum	145 PSI
Température recommandée d'eau chaude	120° - 140° F*
Température maximum d'eau chaude	176° F*
Capacité nominale	1.2 GPM

\* Vous devez connaître et respecter tous les codes de plomberie locaux applicables pour le réglage de la température du chauffe-eau.

**À prendre en considération pour l'installation**

- Pour de meilleurs résultats, Hansgrohe recommande que ce produit soit installé par un plombier professionnel licencié.
- Veuillez lire attentivement ces instructions avant de procéder à l'installation. Assurez-vous de disposer de tous les outils et du matériel nécessaires pour l'installation.
- Ce dispositif requiert une pièce intérieure 10303181.
- Conservez ce livret et le reçu (ou une autre preuve sur laquelle figurent la date et l'endroit de l'achat) pour ce produit dans un endroit sûr. Le reçu est requis si vous commandez des pièces sous garantie.

## Datos técnicos

Presión recomendada en servicio	15 - 75 PSI
Presión en servicio max.	145 PSI
Temperatura recomendada del agua caliente	120° - 140° F*
Temperatura del agua caliente max.	176° F*
Caudal máximo	1.2 GPM

\*Debe conocer y cumplir todos los códigos locales aplicables para ajustar la temperatura del calentador de agua.

## Consideraciones para la instalación

- Para obtener mejores resultados, la instalación debe estar a cargo de un plomero profesional matriculado.
- Antes de comenzar la instalación, lea estas instrucciones detenidamente. Asegúrese de tener las herramientas y los insumos necesarios para completar la instalación.
- La unidad requiere una pieza interior de válvula 10303181.
- Mantenga este folleto y el recibo (u otro comprobante del lugar y fecha de compra) de este producto en lugar seguro. El recibo se requiere en caso de ser necesario solicitar piezas bajo garantía.

## Tools Required / Outils Utiles / Herramientas Utiles

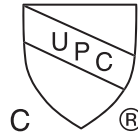
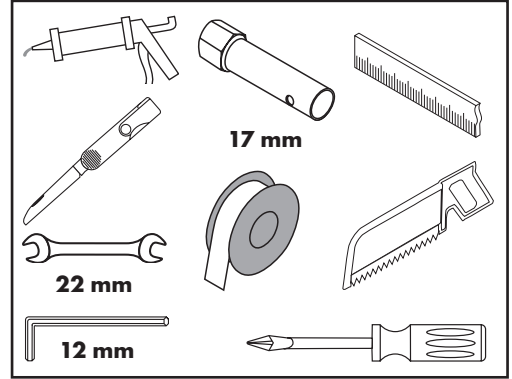

This unit meets or exceeds the following:

- ASME A112.18.1
- CSA B125.1
- Listed by IAPMO for use in the US and Canada
- WaterSense certified

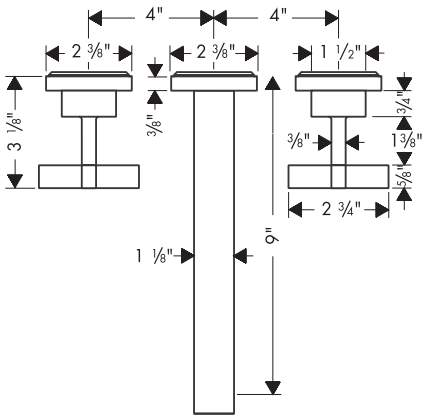

39143xx1

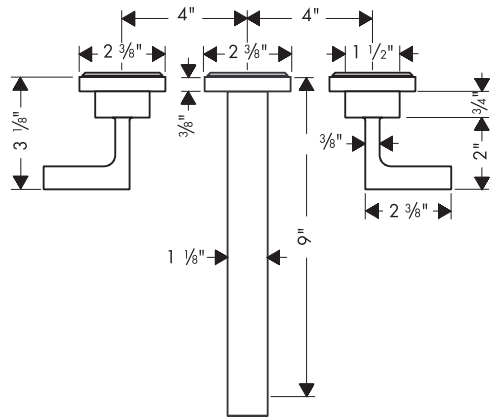

39147xx1

**Suggested Installations / Suggestions d'installation / Sugerencias de instalación**

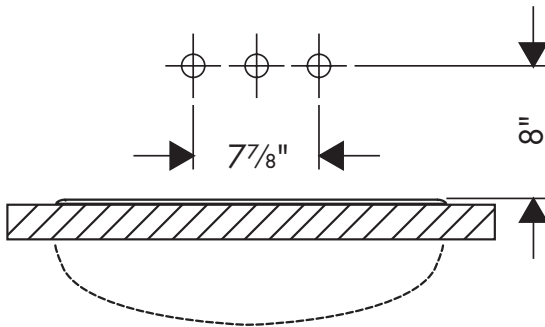

# Installation / Installation / Instalación

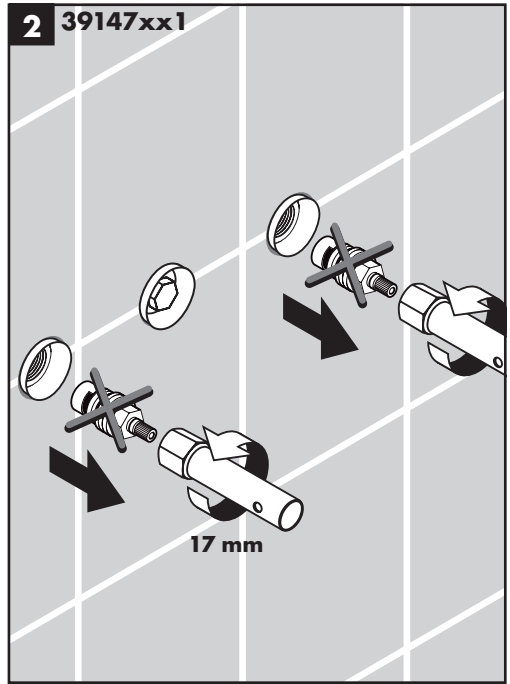
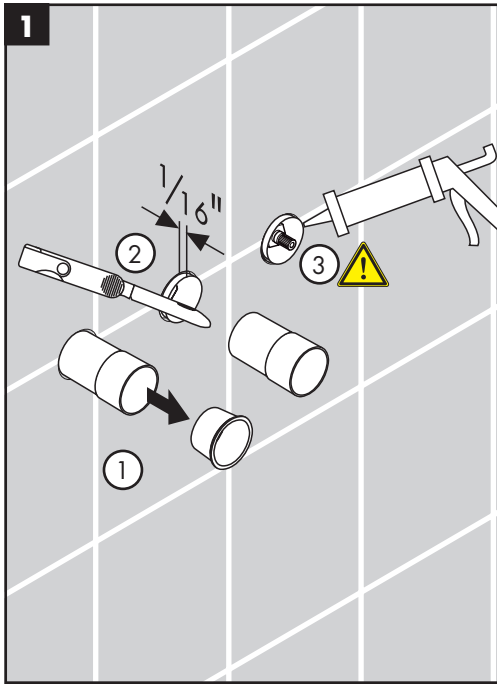

## English

Remove the covers.

Trim the plaster shields so that they extend  $\frac{1}{16}$ " outside the surface of the finished wall

 **Seal the wall around the plaster shields with waterproof sealant.**

 **Failure to seal the wall can lead to possible water damage.**

### Model #39147xx1 only:

Remove the cartridges.

## Français

Retirez les capuchons.

Coupez le protecteur de façon à ce qu'une partie de  $\frac{1}{16}$  po soit à l'extérieur de la surface du mur fini.

 **Sellez le mur autour du protecteur à l'aide d'un agent d'étanchéité.**

 **Si le mur n'est pas scellé, l'eau pourrait éventuellement causer des dommages.**

### #39147xx1 Seulement:

Retirez les cartouches.

## Español

Retire las tapas.

Corte el protector de yeso de modo que sobresalga  $\frac{1}{16}$ " de la superficie de la pared terminada.

 **Selle la pared alrededor del protector de yeso con un sellador impermeable.**

 **Si no se sella la pared, pueden producirse daños por acción del agua.**

### Nº 39147xx1 solamente:

Retire los cartuchos.

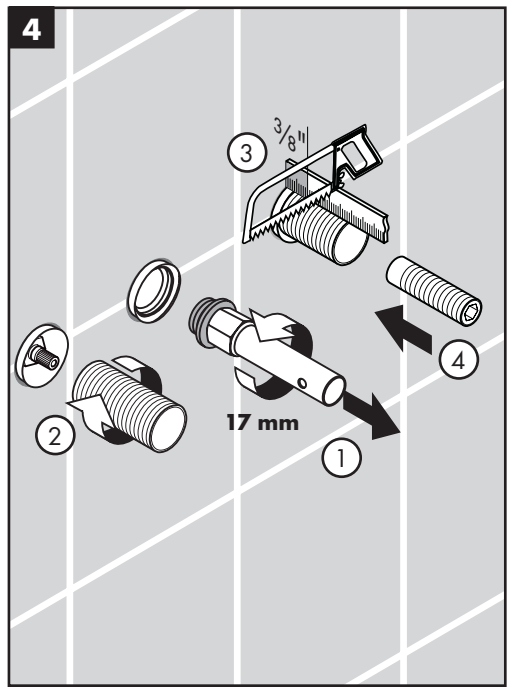
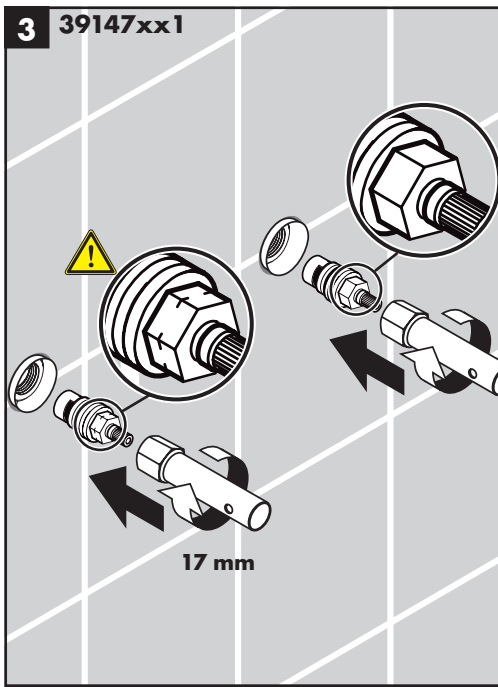

### English

Install the new cartridges.

### Français

Installez les nouvelles cartouches.

### Español

Instale los cartuchos nuevos.

### All models:

Remove the plug from the spout port.

Install the coupling over the stem.

Cut the coupling so that it extends  $\frac{3}{8}$ " outside the surface of the finished wall.

Install the extension spindle.

### Tous les modèles:

Retirez le bouchon du port de bec.

Installez le raccord à glissement.

Coupez le raccord à glissement de façon à ce qu'une partie de  $\frac{3}{8}$  po soit à l'extérieur de la surface du mur fini .

Installez la tige d'extension.

### Todos los modelos:

Retire el tapón del orificio del surtidor.

Instale el acoplamiento deslizante.

Corte el acoplamiento deslizante de modo que sobresalga  $\frac{3}{8}$ " de la superficie de la pared terminada.

Instale el husillo de extensión.

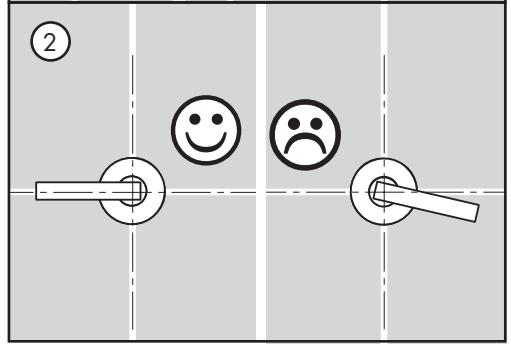
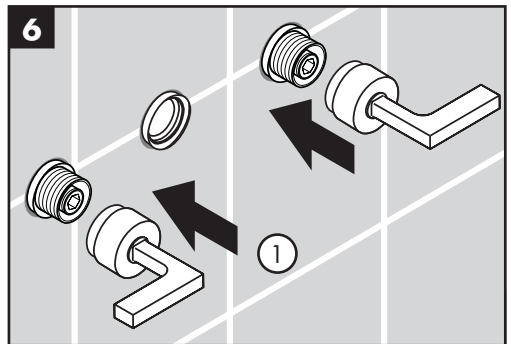
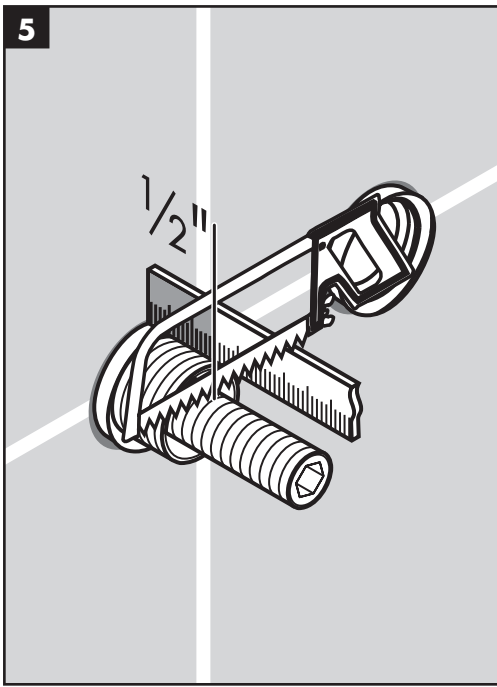

**English**

Cut the extension spindle so that it extends 1/2" outside the surface of the finished wall.

Install the handles.

Inspect the alignment of the handles.

**Français**

Coupez la tige d'extension de façon à ce qu'une partie de 1/2 po soit à l'extérieur de la surface du mur fini .

Installez les poignées.

Vérifiez l'alignement des poignées.

**Español**

Corte el husillo de extensión de modo que sobresalga 1/2" de la superficie de la pared terminada.

Instale las manijas.

Inspeccione la alineación de las manijas.

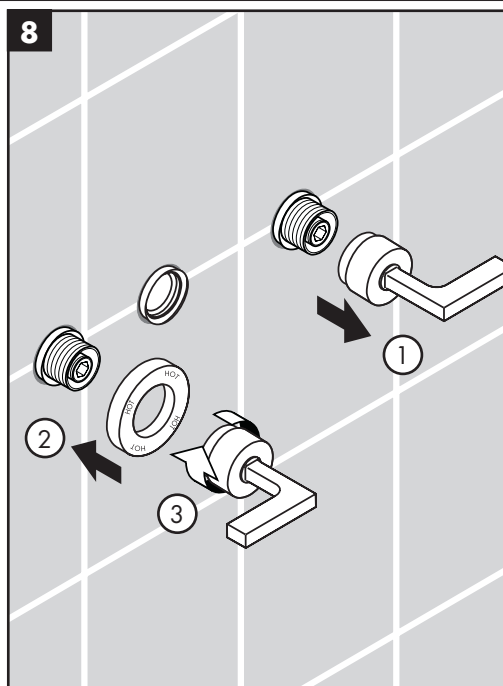
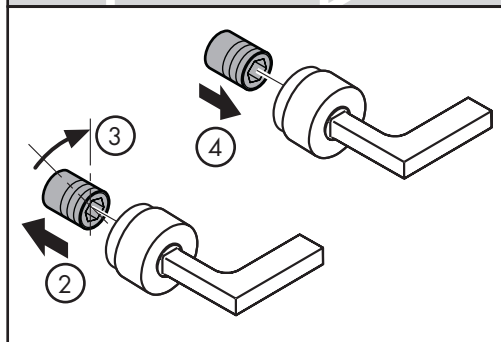
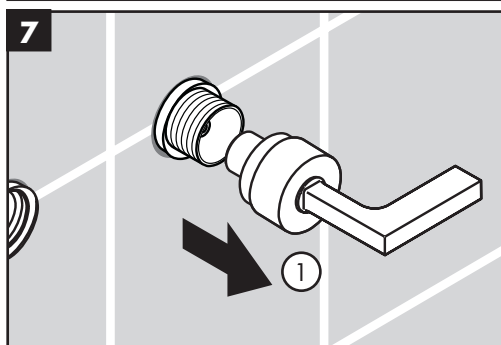

## English

If it is not satisfactory, remove the handle.

Remove the extension spindle from the handle. Rotate it slightly and reinstall it.

Install the escutcheons and the handles.

## Français

Si l'alignement n'est pas satisfaisant, retirez la poignée.

Retirez le tige d'extension, tournez-la légèrement, puis réinstallez-la.

Installez les écussons et les poignées.

## Español

Si la alineación no es satisfactoria, retire la manija.

Retire el husillo de extensión, gírelo levemente y reinstálo.

Instale los escudos y las manijas.



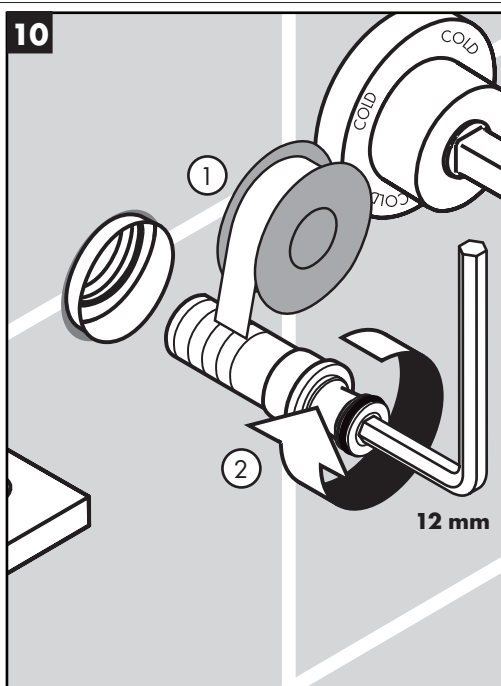
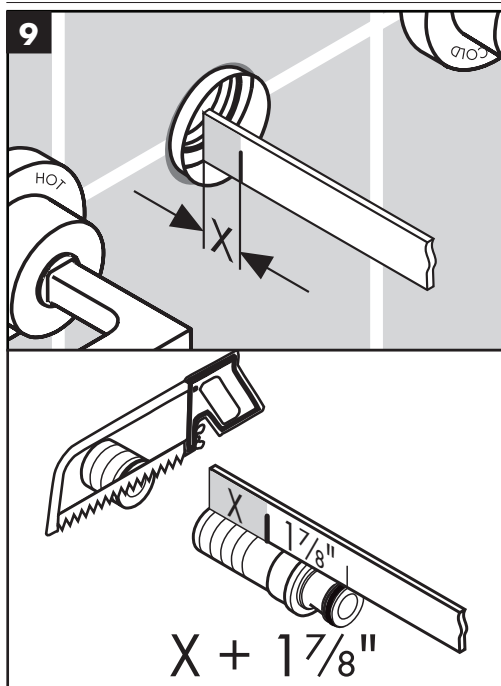

## English

Measure the distance between the rough and the end of the plaster shield. Record this measurement ("X").

Add  $1\frac{7}{8}$ " to this measurement.

Cut the connecting thread so that it is  $X + 1\frac{7}{8}$ " long.

Wrap the threads on the connecting thread with plumber's tape.

Install the connecting thread.

## Français

Mesurez la distance entre la surface de la pièce du port de bec de remplissage et le rebord extérieur du protecteur (« X »).

Ajoutez  $1\frac{7}{8}$  po à la mesure « X ».

Coupez le raccord fileté de façon à ce qu'il mesure « X » +  $1\frac{7}{8}$  po de long.

Enveloppez les filets sur le raccord fileté avec du ruban de plomberie.

Installez le raccord.

## Español

Mida la distancia desde la superficie de la parte interna del orificio del surtidor hasta el borde externo del protector de yeso ("X").

Agregue  $1\frac{7}{8}$ " mm a X.

Corte el niple roscado para que tenga  $X + 1\frac{7}{8}$ " de largo.

Envuelva las roscas del niple con cinta de plomería.

Instale el niple.

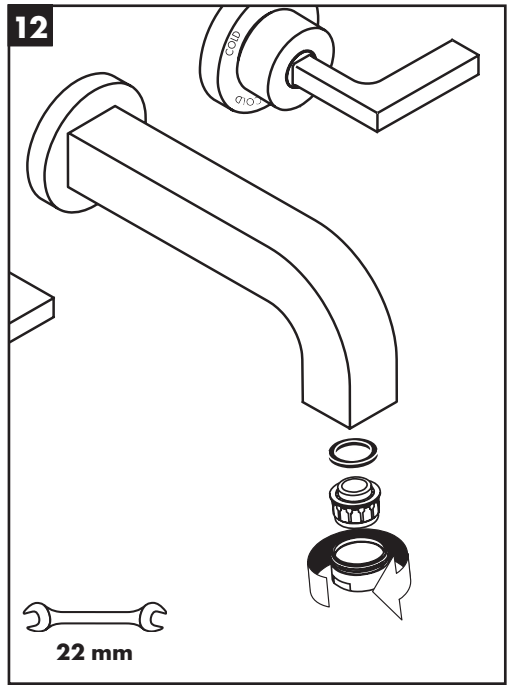
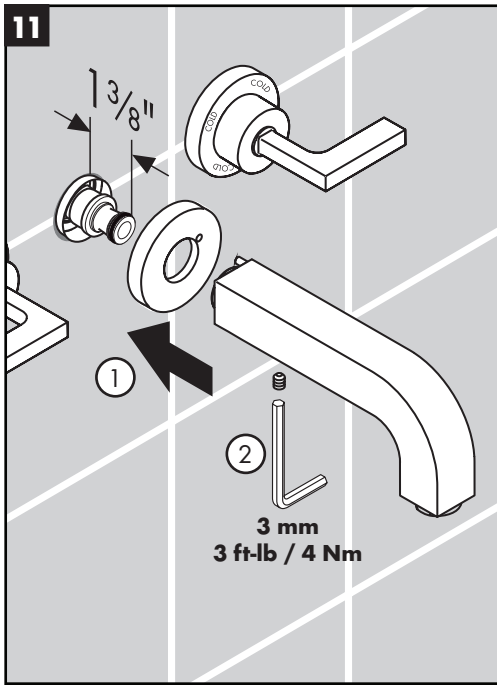

## English

The connecting thread should extend  $1\frac{3}{8}$ " outside the surface of the finished wall.

Install the spout escutcheon. Install the spout. Tighten the screw.

Remove the aerator.

## Français

Installez le raccord fileté.

Le niple devrait étendre  $1\frac{3}{8}$  po hors de la surface du mur fini.

Installez l'écusson du bec. Installez le bec. Serrez le vis du bec.

Retirez l'aérateur.

## Español

El niple debe extender  $1\frac{3}{8}$ " fuera de la superficie del acabado de la pared.

Instale el escudo del surtidor. Instale el surtidor. Apriete el tornillo del surtidor.

Retire el aireador.

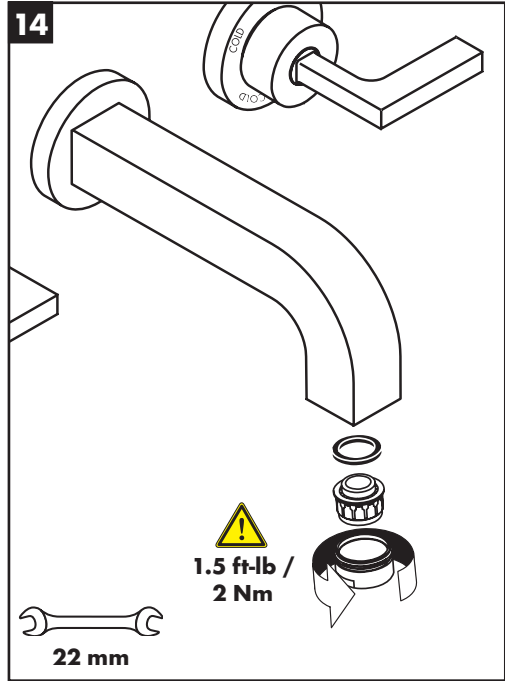
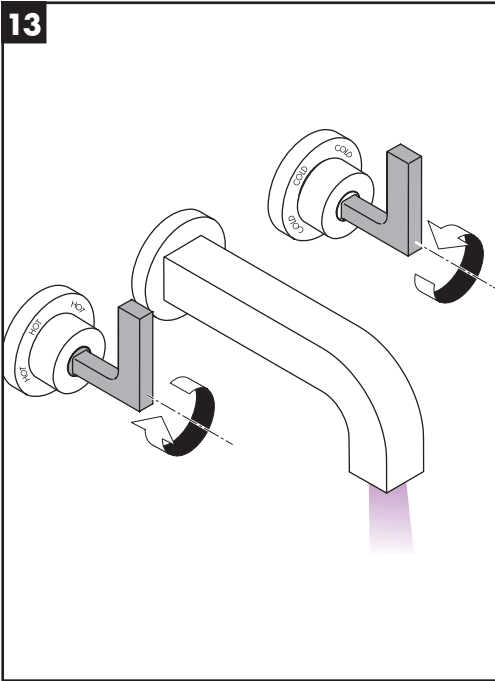

## English

Flush the hot and cold supplies for at least 2 minutes.

Install the aerator.

 **Do not over-tighten the aerator.**

## Français

Rincez le robinet pendant au moins 2 minutes.

Installez l'aérateur.

 **Ne serrez pas trop l'aérateur, vous pourriez l'endommager.**

## Español

Lave el grifo durante al menos 2 minutos.

Instale el aireador.

 **No apriete el aireador en exceso, puesto que podría dañarlo.**

# Replacement Parts / Pièces détachées / Repuestos

## 39147xx1

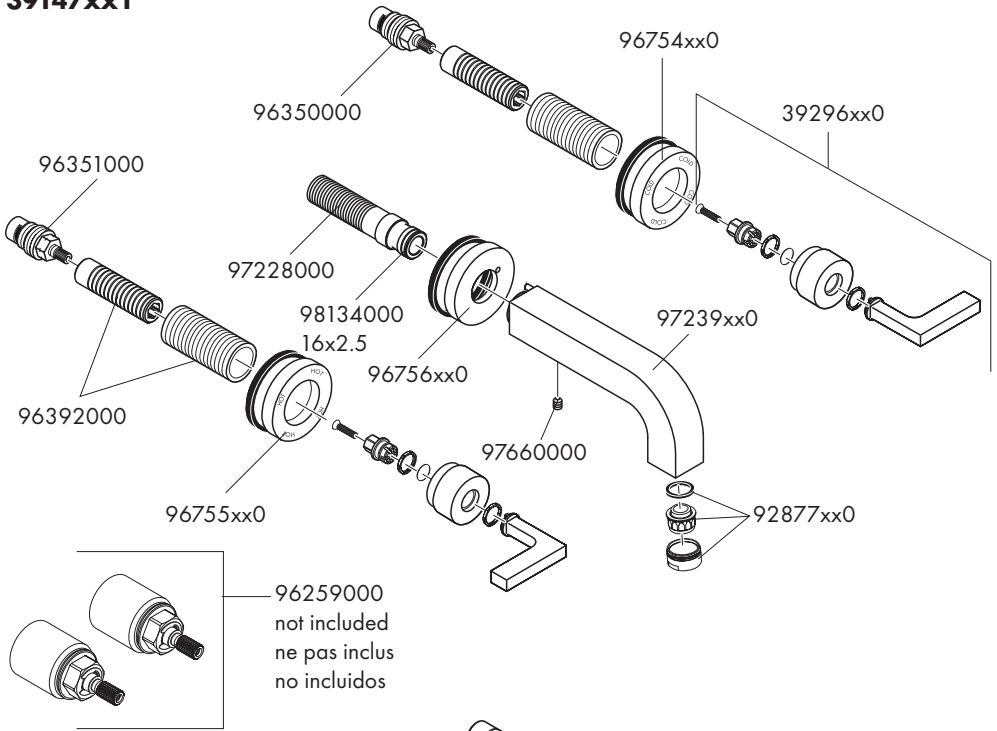

## 39143xx1

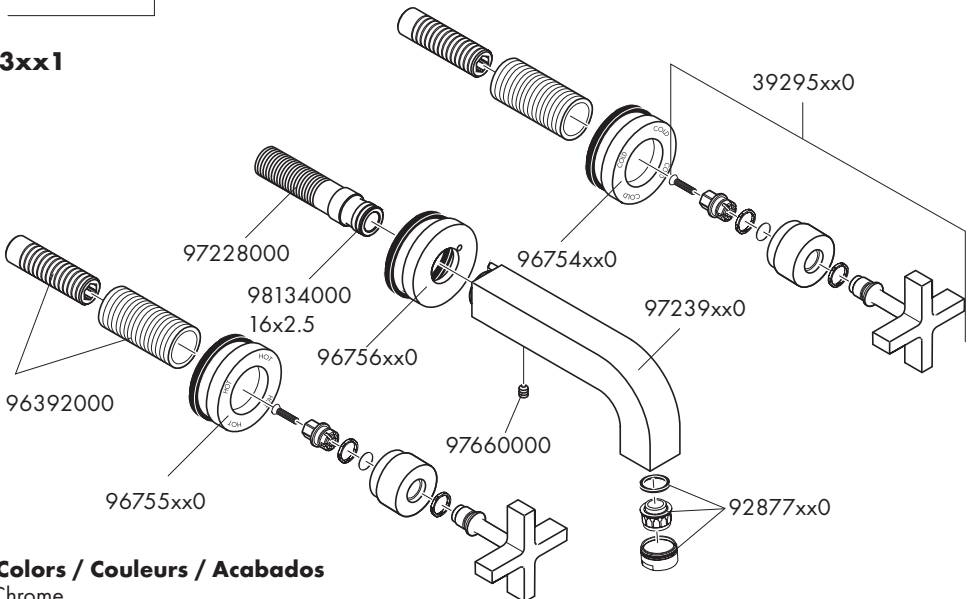

**xx = Colors / Couleurs / Acabados**  
00 = Chrome  
82 = Brushed Nickel

User Instructions / Instructions de service / Manejo

39147xx1

off  
fermé  
cerrar

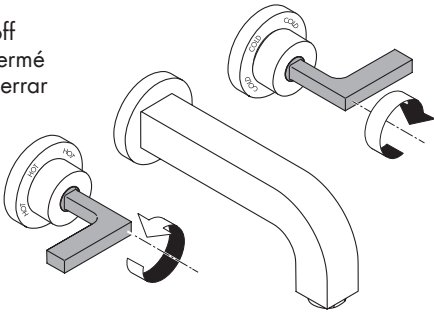

on  
ouvert  
abierto

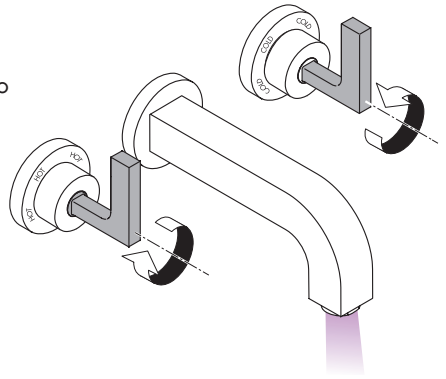

cold  
froid  
frío

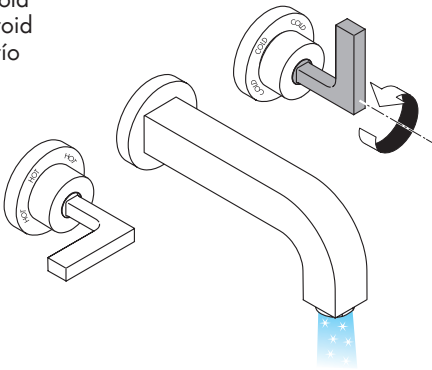

hot  
chaud  
caliente

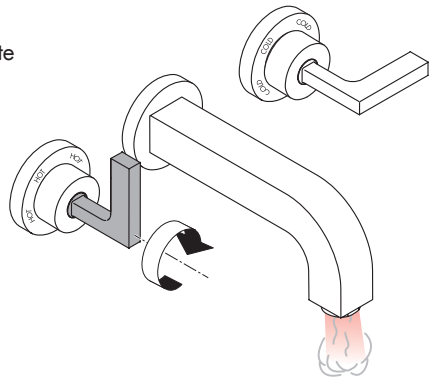

User Instructions / Instructions de service / Manejo

39143xx1

off  
fermé  
cerrar

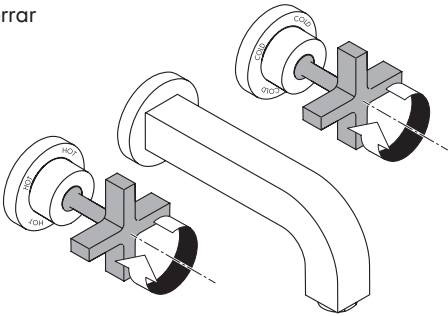

on  
ouvert  
abierto

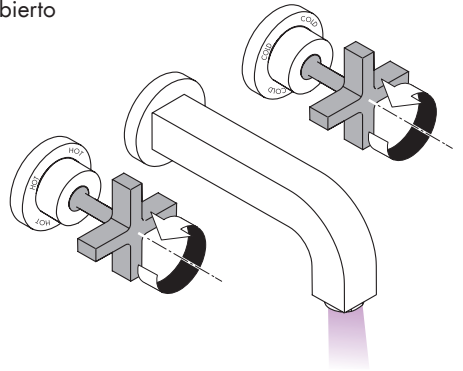

cold  
froid  
frío

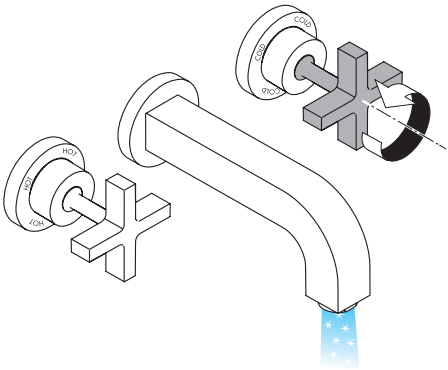

hot  
chaud  
caliente

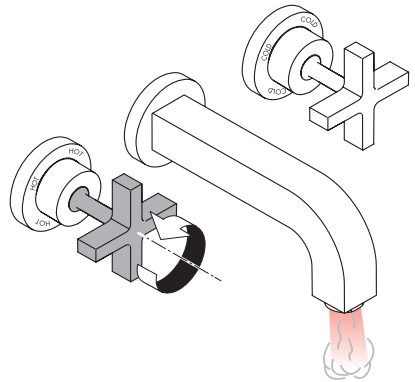

Cleaning / Nettoyage / Limpieza

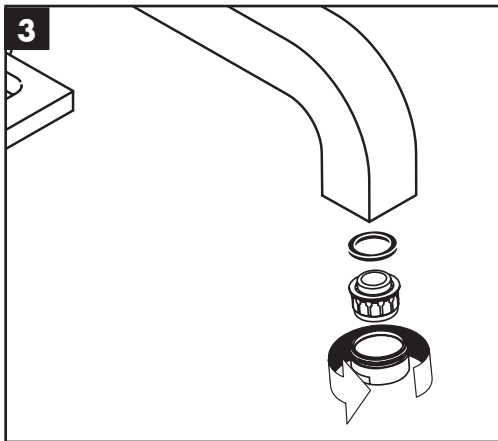
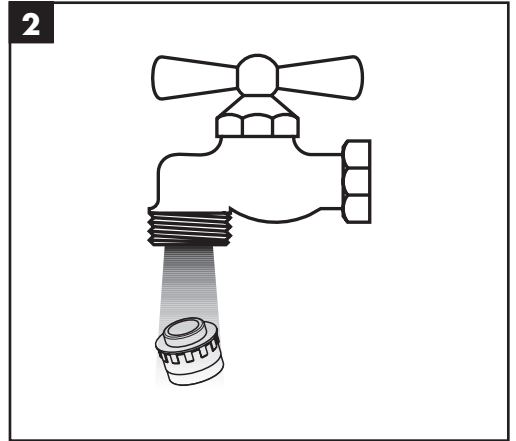
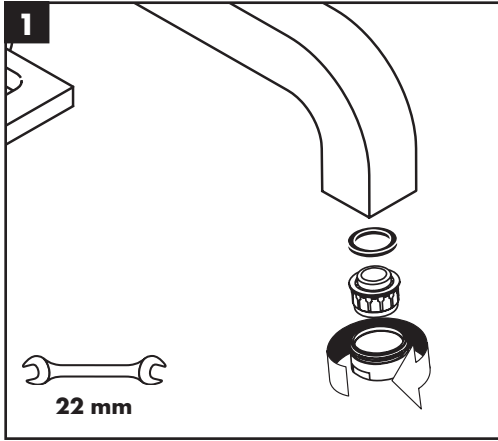

## Cleaning Recommendation for Hansgrohe Products

---

Modern bathroom faucets, kitchen faucets and shower products are made from different materials to comply with the needs of the market with regard to design and functionality. To avoid damage to the product, it is necessary to take proper care of it.

### For best results:

- Prevent the buildup of mineral scale and /or soap residue by cleaning your Hansgrohe product(s) when needed.
- Select a cleaning agent specifically intended for the type of product.
- **Do not** use these types of cleaners as they will cause damage to your Hansgrohe product:
  - ✗ Any cleaning agent containing hydrochloric acid, formic acid, lye, or acetic acid.
  - ✗ Abrasive cleaning powders, pads, or brushes.
  - ✗ Steam cleaners.
  - ✗ "No rinse" cleaning agents.
- **Always** follow the instructions provided by the manufacturer of the cleaning agent.
- **Do not** mix cleaning agents, unless directed by the manufacturer.
- **Do not** spray cleaners directly onto the product as drops could enter openings and gaps and cause damage. When using spray cleaners, spray the cleaner onto a soft cloth or sponge.
- **Always** rinse your Hansgrohe product thoroughly with clear water and polish dry with a soft cloth after cleaning.

### Important

- Residue from soaps, shampoos, hair dye, and other toiletries and cosmetics can cause damage. Rinse the product with clean water after each use.
- Residue from basin/tub/tile cleaner can cause damage to faucets and fittings. Immediately rinse any overspray from the Hansgrohe product.
- Do not store any cleaning agents under your Hansgrohe product, such as in a vanity unit, as the fumes may damage the product.
- **Damage to the product caused by improper care or the use of improper cleaning agents is not covered by the warranty.**
- **If a component of the product is damaged, replace it, as there is risk of injury.**

## Conseil de nettoyage pour les produits Hansgrohe

---

Les robinets pour les salles de bains et les cuisines modernes ainsi que les produits récents pour les douches se composent de matériaux différents afin de satisfaire aux besoins du marché en termes de conception et de fonctionnalité. Afin d'éviter d'endommager le produit, il est nécessaire d'en prendre soin.

### Pour de meilleurs résultats :

- Empêchez l'accumulation de tarte et/ou de résidu de savon en nettoyant votre produit Hansgrohe lorsque c'est nécessaire.
- Sélectionnez un produit de nettoyage spécifiquement prévu pour ce type de produit.
- **N'utilisez pas** ces types de nettoyeurs car ils peuvent endommager votre produit Hansgrohe :
  - ✗ Tout produit de nettoyage contenant de l'acide chlorhydrique, de l'acide formique, de la potasse ou de l'acide acétique.
  - ✗ Les poudres de nettoyage, les tampons ou les brosses abrasives.
  - ✗ Les nettoyeurs à vapeur.
  - ✗ Les produits de nettoyage « sans rinçage ».
- **Ne mélangez pas** les produits de nettoyage, à moins que cela soit indiqué par le fabricant.
- **Ne pulvérisez pas** les nettoyeurs directement sur le produit car des gouttes pourraient entrer dans les ouvertures et



---

les fentes et causer des dommages. Lorsque vous utilisez des nettoyeurs par pulvérisation, pulvérisez le nettoyeur sur un chiffon ou une éponge douce.

### Important

- Les résidus de produits pour le corps comme les savons liquides, shampooings, gels de douche, teintures pour cheveux, parfums, apres-rasage et vernis à ongles peuvent causer des détériorations. Rincez le produit avec de l'eau propre après chaque utilisation.
- Le résidu provenant des nettoyeurs pour cuvette/baignoire/carrelage peut endommager les robinets et les raccords de tuyauterie. Rincez immédiatement toute surpulvérisation sur le produit Hansgrohe.
- De même, il est interdit de stocker des détergents ou des produits chimiques sous les produits, par ex. dans un meuble sous lavabo, car les vapeurs qui s'en dégagent risquent d'abîmer les produits.
- **Les dommages au produit causés par un mauvais entretien ou par l'utilisation de produits de nettoyage inadéquats ne sont pas couverts par la garantie.**
- **Si un composant du produit est endommagé, remplacez-le, car il existe un risque de blessure.**

---

## Recomendación de limpieza para los productos de Hansgrohe

---

Hoy en día, las griferías de baño y de cocina así como duchas modernas se componen de materiales muy distintos para satisfacer las exigencias del mercado respecto al diseño y la funcionalidad. Para evitar daños y reclamaciones hay que tener en cuenta ciertos aspectos tanto en el uso como en su limpieza.

### Para obtener mejores resultados:

- Evite la acumulación de restos de jabón o sarro limpiando el producto Hansgrohe cuando sea necesario.
- Seleccione un agente de limpieza diseñado específicamente para el tipo de producto.
- **No** use estos tipos de limpiadores, ya que causarán daño a su producto Hansgrohe:
  - ✘ Agentes limpiadores que contengan ácido clorhídrico, fórmico, acético o lejía.
  - ✘ Polvos, paños o cepillos de limpieza abrasivos.
  - ✘ Limpiadores a vapor
  - ✘ Agentes de limpieza "sin enjuague".
- **Siempre** siga las instrucciones provistas por el fabricante del agente de limpieza.
- **No** mezcle los agentes de limpieza, a menos que esté indicado por el fabricante.
- **No** rocíe limpiadores directamente sobre el producto, ya que podrían caer gotas sobre las aberturas y espacios y causar daños. Cuando use limpiadores en spray, rocíe el limpiador sobre un paño suave o esponja.
- **Siempre** enjuague su producto Hansgrohe con agua limpia y séquelo y lístrelolo con un paño suave después de la limpieza.

### Importante

- Los residuos de productos de aseo como jabón líquido, champú, gel de ducha, tintes de pelo, perfumes, lociones de afeitado y esmalte de uñas pueden dañar también los materiales. Enjuague el producto con agua limpia después de cada uso.
- Los residuos de limpiadores para lavatorios, bañeras o azulejos pueden causar daño a los grifos y accesorios. Enjuague inmediatamente cualquier derrame que haya sobre el producto de Hansgrohe.
- Tampoco pueden generarse depósitos de productos de limpieza o químicos debajo de los productos, p. ej. En un armario de lavabo. De lo contrario, los vapores generados pueden dañar los productos.
- **Los daños que resulten de un cuidado inadecuado o uso de agentes de limpieza inadecuados no están cubiertos por la garantía.**
- **Si se daña un componente del producto, reemplácelo, ya que existe riesgo de lesión.**

## Limited Consumer Warranty

---

This product has been manufactured and tested to the highest quality standards by Hansgrohe, Inc. ("Hansgrohe"). This warranty is limited to Hansgrohe products that are purchased by a consumer in the United States or Canada after March 1, 1996, and installed in either the United States or in Canada.

### WHO IS COVERED BY THE WARRANTY

This warranty extends to the original purchaser only. This warranty is non-transferable.

### WHAT IS COVERED BY THE WARRANTY

The warranty covers only your Hansgrohe manufactured product. Hansgrohe warrants this product against defects in material or workmanship as follows:

Hansgrohe will replace at no charge for parts only or, at its option, replace any product or part of the product that proves defective because of improper workmanship and/or material, under normal installation, use, service and maintenance. If Hansgrohe is unable to provide a replacement and repair is not practical or cannot be made in timely fashion, Hansgrohe may elect to refund the purchase price in exchange for the return of the product.

### LENGTH OF WARRANTY

Replacement or repaired parts of products will be covered for the term of this warranty, as stated in the following two sentences. If you are a consumer who purchased the product for use primarily for personal, family or household purposes, this warranty extends for as long as you own the product and the home in which the product is originally installed. If you purchased the product for use primarily for any other purpose, including, without limitation, a commercial purpose, this warranty extends only (i) for 1 year, with respect to Hansgrohe & Commercial products, and (ii) for 5 years, with respect to Axor products.

### THIS WARRANTY DOES NOT COVER, AND HANSGROHE WILL NOT PAY FOR:

- A. Conditions, malfunctions or damage not resulting from defects in material or workmanship.
- B. Conditions, malfunctions or damage resulting from (1) normal wear and tear, improper installation, improper maintenance, misuse, abuse, negligence, accident or alteration; (2) the use of abrasive or caustic cleaning agents or "no-rinse" cleaning products, or the use of the product in any manner contrary to the product instructions; or (3) conditions in the home such as excessive water pressure or corrosion.
- C. Labor and other expenses for disconnection, deinstallation, or return of the product for warranty service (including but not limited to proper packaging and shipping costs), or for installation or reinstallation of the product.
- D. Accessories, connected materials and products, or related products not manufactured by Hansgrohe.
- E. Any Hansgrohe or Axor product sold for display purposes.
- F. Hansgrohe Water Filtration System is subject to a 1-year limited warranty. Warranty does not include replacement filters.

### TO OBTAIN WARRANTY PARTS OR INFORMATION

Contact your Hansgrohe retailer, or contact Technical Service at:

Hansgrohe, Inc.  
1492 Bluegrass Lakes Parkway  
Alpharetta, GA 30004  
Toll-free 800-334-0455

In requesting warranty service, you will need to provide:

- 1. The sales receipt or other evidence of the date and place of purchase.
- 2. A description of the problem.
- 3. Delivery of the product or the defective part, postage prepaid and carefully packed and insured, to:

Hansgrohe, Inc.  
1492 Bluegrass Lakes Parkway  
Alpharetta, GA 30004  
Toll-free 800-334-0455

When warranty service is completed, any repaired or replacement product or part will be returned to you postage prepaid.

---

## Exclusions and Limitations

**REPAIR OR REPLACEMENT (OR, IN LIMITED CIRCUMSTANCES, REFUND OF THE PURCHASE PRICE) AS PROVIDED UNDER THIS WARRANTY IS THE EXCLUSIVE REMEDY OF THE PURCHASER. HANSGROHE NEITHER ASSUMES NOR AUTHORIZES ANY PERSON TO CREATE FOR IT ANY OTHER OBLIGATION OR LIABILITY IN CONNECTION WITH THIS PRODUCT.**

**HANSGROHE SHALL NOT BE LIABLE TO PURCHASER OR ANY OTHER PERSON FOR ANY INCIDENTAL, SPECIAL OR CONSEQUENTIAL DAMAGES, ARISING OUT OF BREACH OF THIS WARRANTY OR ANY IMPLIED WARRANTY (INCLUDING BUT NOT LIMITED TO ANY IMPLIED WARRANTY OF MERCHANTABILITY).**

Some States do not allow the exclusion or limitation of incidental or consequential damages, so the above limitation or exclusion may not apply to you. This warranty gives you specific legal rights, and you may also have other rights that vary from state to state.

**TO THE EXTENT PERMITTED BY LAW, ANY IMPLIED WARRANTIES OF MERCHANTABILITY AND FITNESS FOR A PARTICULAR PURPOSE, ARE LIMITED TO THE DURATION OF THE EXPRESS WARRANTY.**

Some states do not allow limitations on how long an implied warranty may last, so the above limitations may not apply to you.

You may be required by law to give us a reasonable opportunity to correct or cure any failure to comply before you can bring any action in court against us under the Magnuson-Moss Warranty Act.

### PRODUCT INSTRUCTIONS AND QUESTIONS

Upon purchase or prior to installation, please carefully inspect your Hansgrohe product for any damage or visible defect. Prior to installing, always carefully study the enclosed instructions on the proper installation and the care and maintenance of this product. If you have questions at any time about the use, installation or performance of your Hansgrohe product, or this warranty, please write us or call us toll-free at 800-334-0455.

---

**hansgrohe**

Hansgrohe, Inc. • 1490 Bluegrass Lakes Parkway • Alpharetta, GA 30004  
Tel. 800-334-0455 • Fax 770-889-1783

[www.hansgrohe-usa.com](http://www.hansgrohe-usa.com)