

AXOR[®]

hansgrohe

- EN** Installation / User Instructions / Warranty
- FR** Instructions de montage / Mode d'emploi / Garantie
- ES** Instrucciones de montaje / Manejo / Garantía

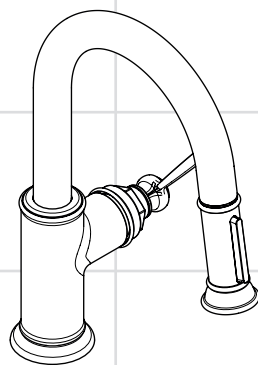

Montreux
16584xx1

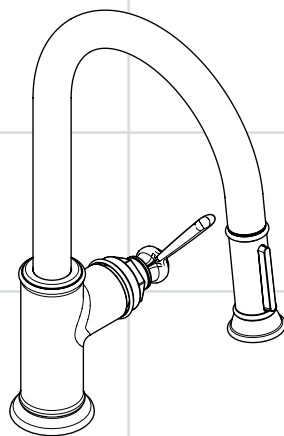

Montreux
16581xx1

Technical Information

Recommended water pressure	15 - 75 PSI
Max. water pressure	145 PSI
Recommended hot water temp.	120° - 140° F*
Max. hot water temp	176° F*
Flow rate	1.75 GPM
Hole size in mounting surface	1 1/2"
Max. depth of mounting surface	2 3/4"

* Please know and follow all applicable local plumbing codes when setting the temperature on the water heater.

Installation Considerations

- For best results, Hansgrohe recommends that this unit be installed by a licensed, professional plumber.
- Please read over these instructions thoroughly before beginning installation. Make sure that you have all tools and supplies needed to complete the installation.
- Protection against backflow is provided by a double check valve.

⚠ Do not rotate the spout further than 360° or damage to the hose will result.

- Keep this booklet and the receipt (or other proof of date and place of purchase) for this product in a safe place. The receipt is required should it be necessary to request warranty parts.

Données techniques

Pression d'eau recommandée	15 - 75 PSI
Pression d'eau maximum	145 PSI
Température recommandée d'eau chaude	120° - 140° F*
Température maximum d'eau chaude	176° F*
Capacité nominale	1.75 GPM
Dimension du trou dans la surface de montage	1 1/2 po
Profondeur maximale de la surface de montage	2 3/4 po

* Vous devez connaître et respecter tous les codes de plomberie locaux applicables pour le réglage de la température du chauffe-eau.

À prendre en considération pour l'installation

- Pour de meilleurs résultats, Hansgrohe recommande que ce produit soit installé par un plombier professionnel licencié.
- Veuillez lire attentivement ces instructions avant de procéder à l'installation. Assurez-vous de disposer de tous les outils et du matériel nécessaires pour l'installation.
- La protection contre le retour d'eau est fournie par un clapet de non-retour double.

⚠ Le bec ne peut être tourné à plus de 360° sinon le flexible risquerait d'être détérioré.

- Conservez ce livret et le reçu (ou une autre preuve sur laquelle figurent la date et l'endroit de l'achat) pour ce produit dans un endroit sûr. Le reçu est requis si vous commandez des pièces sous garantie.

Datos técnicos

Presión recomendada en servicio	15 - 75 PSI
Presión en servicio max.	145 PSI
Temperatura recomendada del agua caliente	120° - 140° F*
Temperatura del agua caliente max.	176° F*
Caudal máximo	1.75 GPM
Tamaño del orificio en la superficie de montaje	1 1/2"
Profundidad máxima de la superficie de montaje	2 3/4"

* Debe conocer y cumplir todos los códigos locales aplicables para ajustar la temperatura del calentador de agua.

Consideraciones para la instalación

- Para obtener mejores resultados, la instalación debe estar a cargo de un plomero profesional matriculado.
- Antes de comenzar la instalación, lea estas instrucciones detenidamente. Asegúrese de tener las herramientas y los insumos necesarios para completar la instalación.

⚠ No girar el caño más de 360° o el flexo podría resultar dañado.

- La protección contra flujo inverso se proporciona mediante una válvula de retención doble.
- Mantenga este folleto y el recibo (u otro comprobante del lugar y fecha de compra) de este producto en lugar seguro. El recibo se requiere en caso de ser necesario solicitar piezas bajo garantía.

Tools Required / Outils Utiles / Herramientas Útiles

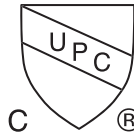
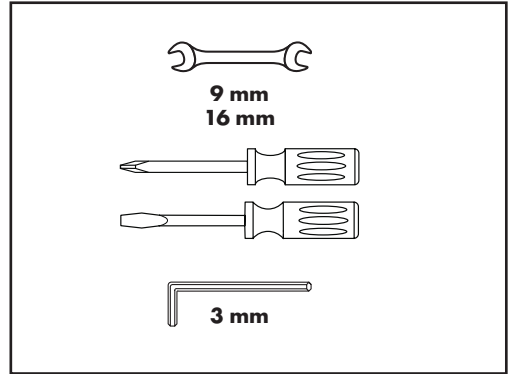

This unit meets or exceeds the following:

- ASME A112.18.1 / CSA B125.1
- Listed by IAPMO for use in the US and Canada

Montreux
16581xx1

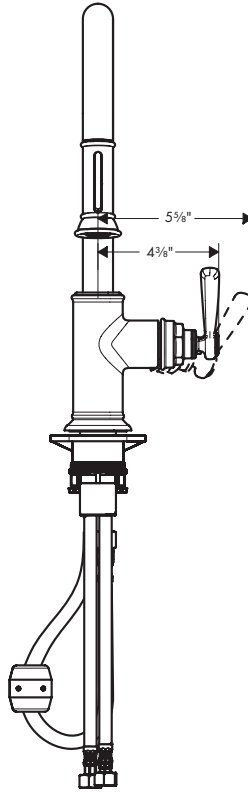
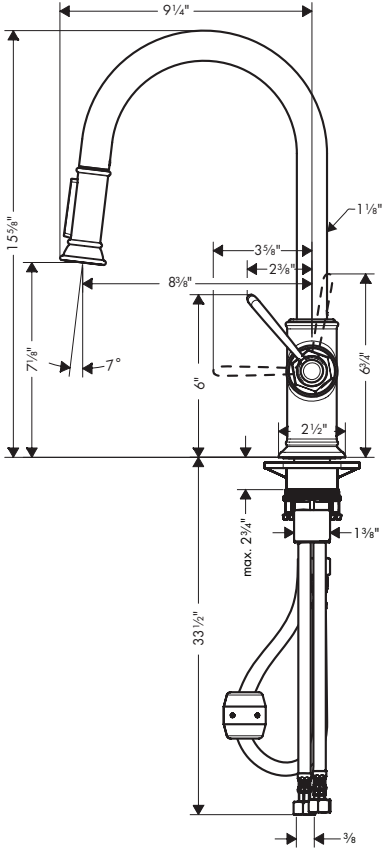

Montreux
16584xx1

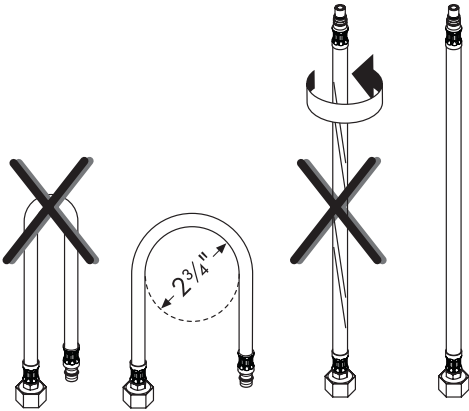
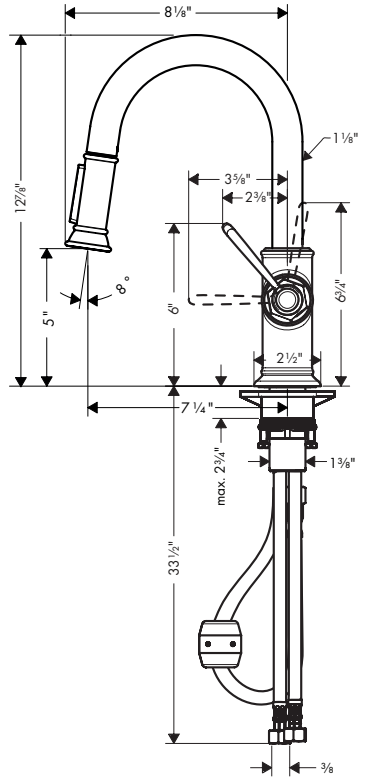

Optional: Adjust the spout rotation / En Option : Ajustez la Rotation du Bec / Opcional: Ajuste la Rotación del Surtidor

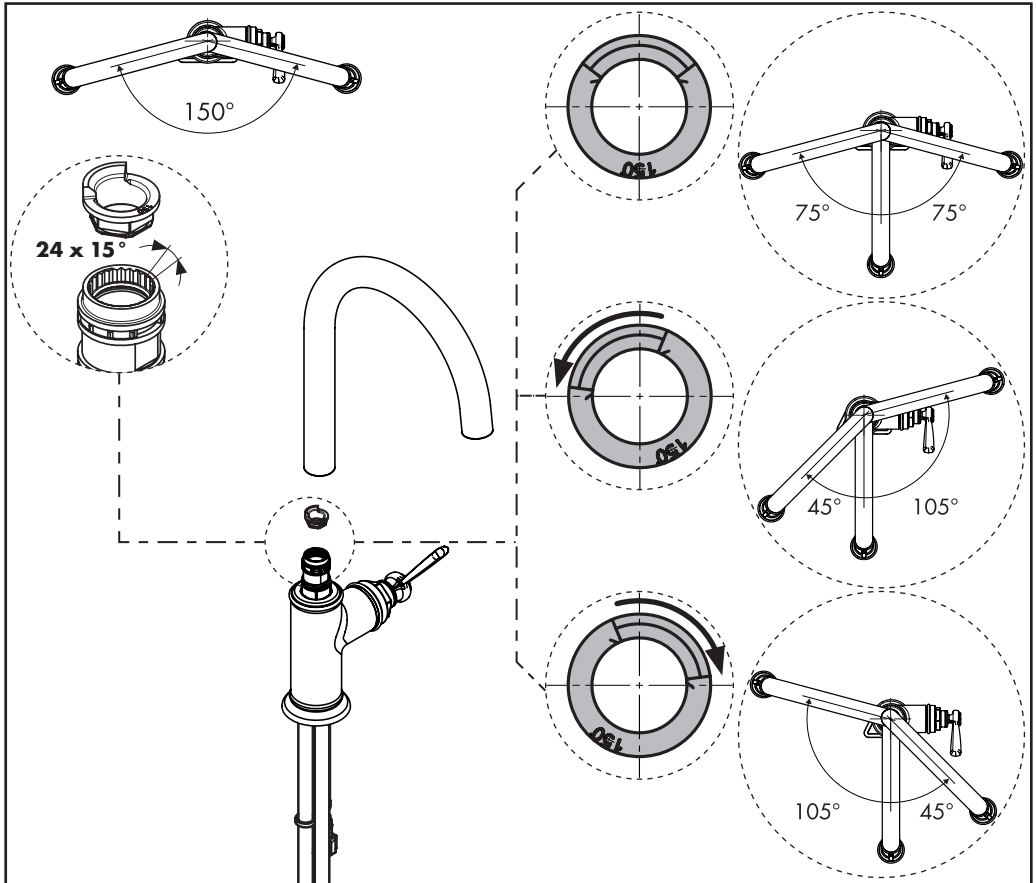

English

With the spout cam in place, the spout will rotate 75° to the right, and 75° to the left of center.

Reposition the cam to change the rotation.

Repositioning the cam one "tooth" results in a 15° change.

Français

Avec la came de bec installée, le bec pivotera de 75° vers la droite, et 75° vers la gauche.

Repositionnez la came pour changer la rotation.

Le fait de repositionner la came d'une dent permet d'obtenir un changement de 15°.

Español

Con la leva del surtidor en su lugar, el surtidor rotará 75° hacia la derecha y 75° a la izquierda.

Reposicione la leva para cambiar la rotación.

Reposicionar la leva un diente resulta en un cambio de 15°.

Installation / Installation / Instalación

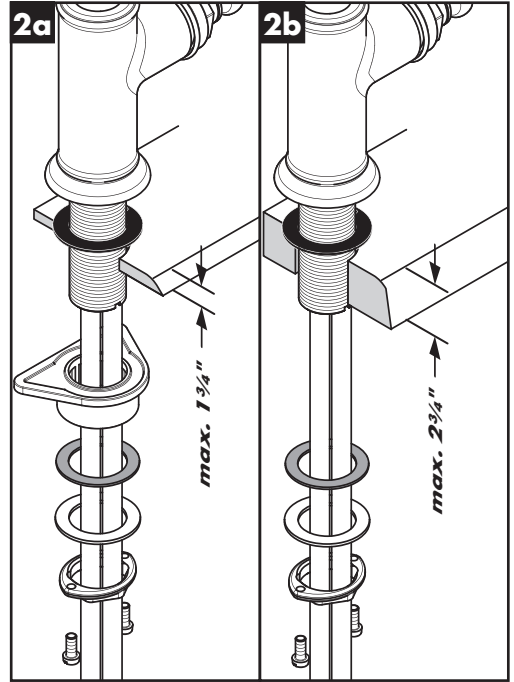
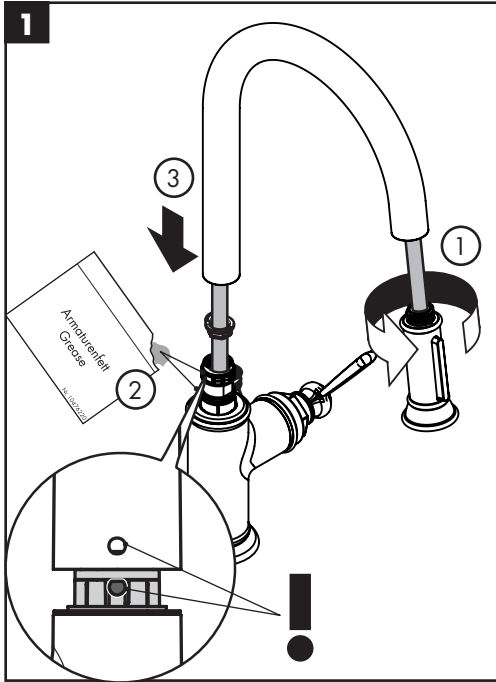

English

Install the handspray hose and handspray.

Lightly lubricate the o-ring and glide rings using white grease.

Push the spout onto the faucet body so that the pin goes into the hole on the rear of the spout.

Place the faucet and sealing ring on the mounting surface.

Install the plastic washer, friction washer, metal washer, and mounting nut.

If the mounting surface is thicker than 1 3/4", or if there is insufficient space, omit the plastic washer.

Français

Installez le tuyau de douche et la douche.

Lubrifiez légèrement le joint torique et les anneaux de glissement.

Poussez le bec sur le corps de robinet pour que l'épingle entre dans le trou sur l'arrière du bec.

Placez l'anneau d'étanchéité et le robinet sur la surface de montage.

Installez la rondelle de plastique, la rondelle en fibre, la rondelle de friction, et l'écrou de montage.

Si l'épaisseur du comptoir dépasse 1 3/4 po, ou si l'espace disponible est insuffisant, omettez la rondelle de plastique.

Español

Instale el flexo de la ducha extraíble y la ducha extraíble.

Lubrique levemente la junta toroidal y los anillos de deslizamiento.

Empuje el surtidor en el cuerpo de chorro para que el alfiler entre en el trasero del chorro.

Coloque el oro de sellado y el grifo sobre la superficie de montaje.

Instale la arandela plástica, la arandela de fibra, la arandela de fricción y la tuerca de fijación.

Si el espesor de la mesada es superior a 1 3/4 pulg. o si no hay suficiente espacio, puede omitirse la arandela plástica.

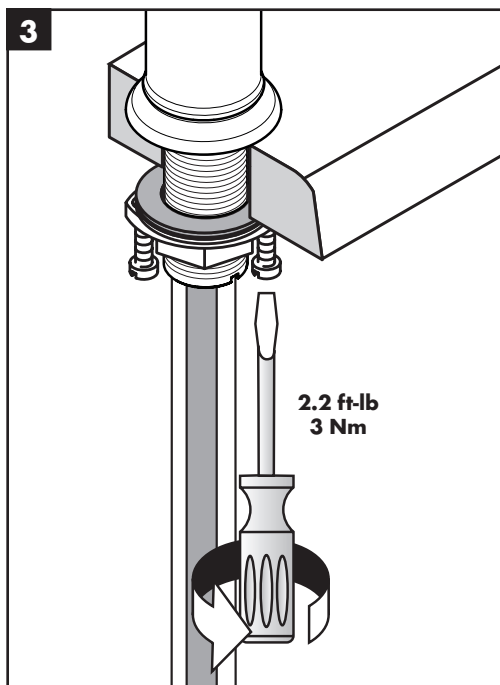

English

Tighten the mounting nut.

Tighten the screws.

Connect the hot and cold supply hoses to the stops.



Use two wrenches.



Do not allow the supply hoses to twist.

Français

Serrez l'écrou de montage.

Serrez les vis de serrage.

Connectez les tuyaux d'arrivée d'eau chaude et d'eau froide aux tuyau d'alimentation.



Servez-vous de deux clés, tel qu'illustre dans le schéma. Serrez fermement à l'aide des clés.



Assurez-vous que les tuyaux n'sentortillent pas.

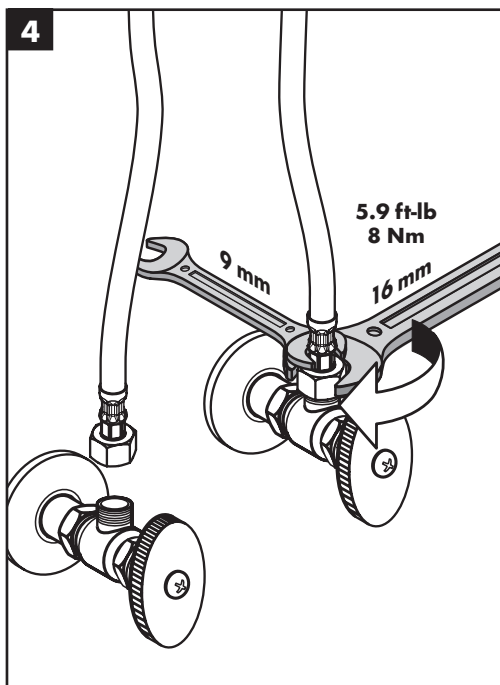

Español

Apriete la tuerca de fijación.

Apriete los tornillos.

Conecte las mangueras de suministro de agua caliente y fría a las alimentaciones de la red.



Use dos llaves, como se ilustra en el diagrama.



No permita que ninguna de los mangueras se retuerza.

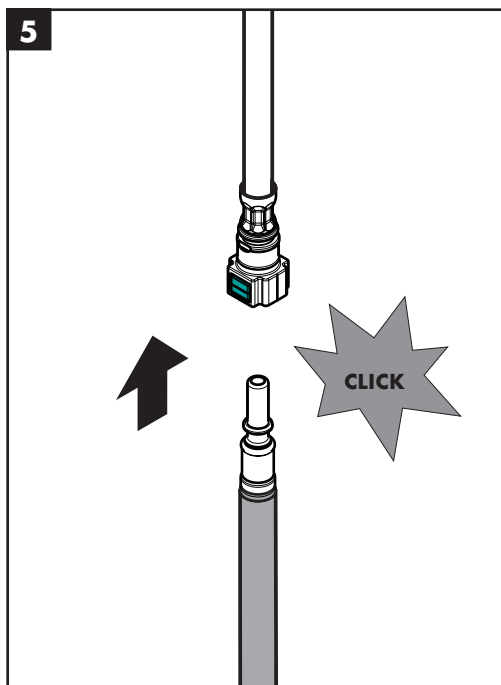

English

Connect the handspray hose to the connection hose.

Install the hose weight.

Test the handspray hose. If it does not retract smoothly, reposition the weight.

Français

Raccordez le tuyau de la douchette au tuyau d'arrivée de la douchette.

Installez le contrepoids sur le tuyau.

Tirez sur la douchette. Elle devrait coulisser facilement et se rétracter sans à-coups. Modifiez la position du contrepoids au besoin.

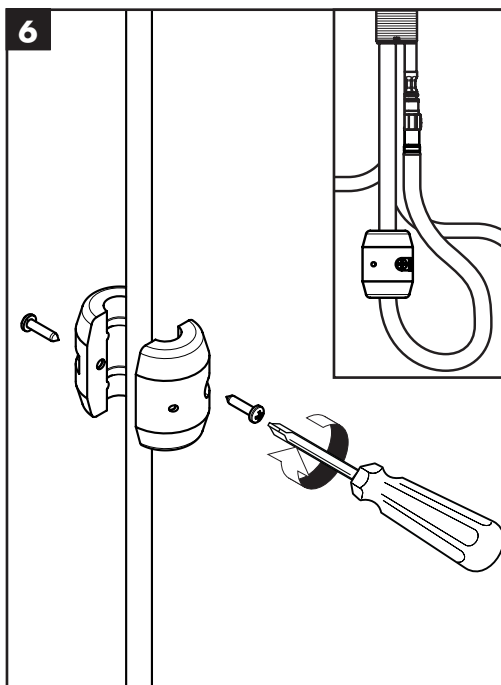

Español

Conecte la manguera de rociador de mano a la manguera de suministro.

Instale el contrapeso.

Tire del rociador de mano. Debe moverse con facilidad y retraerse suavemente. Reposicione el contrapeso según sea necesario.

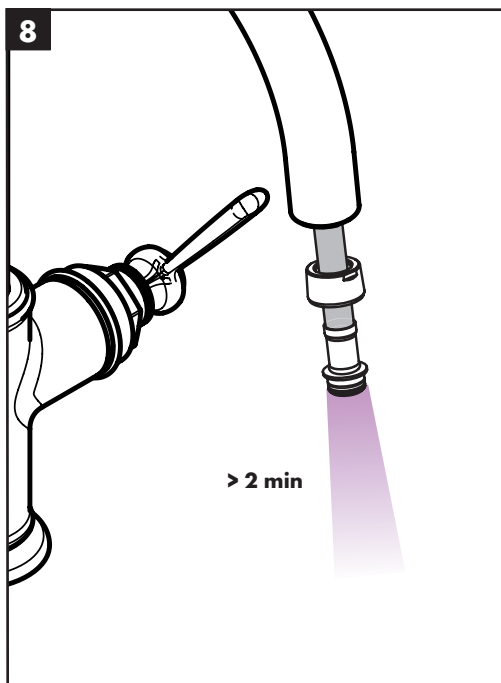
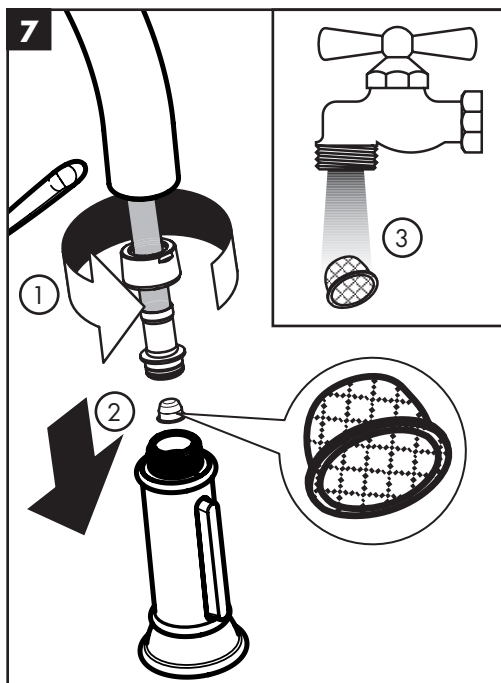

English

Remove the handspray and the hose filter.

Rinse the filter.

Flush the hot and cold supplies for at least two minutes.

Français

Retirez le douchette et le filtre.

Rincez le filtre.

Rincez les conduites d'alimentation de l'eau chaude et de l'eau froide.

Español

Retire la ducha y el filtro de la manguera.

Lave el filtro.

Lave los suministros de agua caliente y fría.

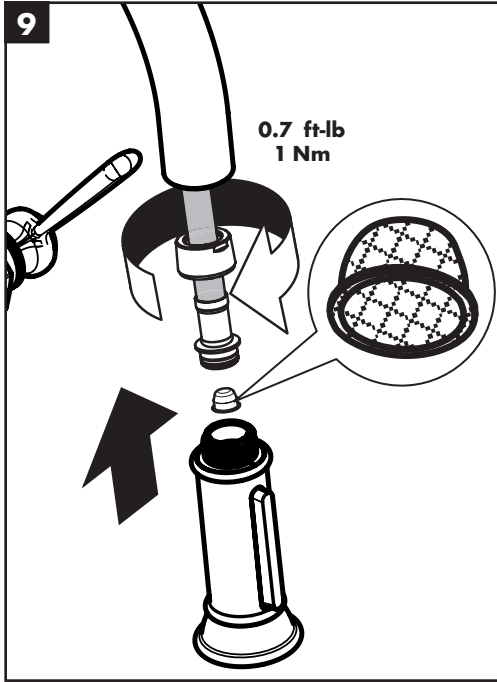

English

Install the hose filter.

Lightly lubricate the hose o-ring.

Install the handspray. Tighten the hose nut.



Do not overtighten the nut or damage to the handspray will result!

Français

Installez le filtre dans le tuyau flexible.

Lubrifiez le joint torique du tuyau.

Installez le douchette. Serrez l'écrou.



Ne pas trop serrez l'écrou.

Español

Instale el filtro en la manguera.

Lubrique ligeramente la junta tórica de la manguera.

Instale la ducha.

Apriete la tuerca de la manguera.



No apriete la tuerca en exceso.

Set the High Temperature Limit Stop / Réglage de la butée limite d'eau chaude / Ajuste el tope de límite de alta temperatura

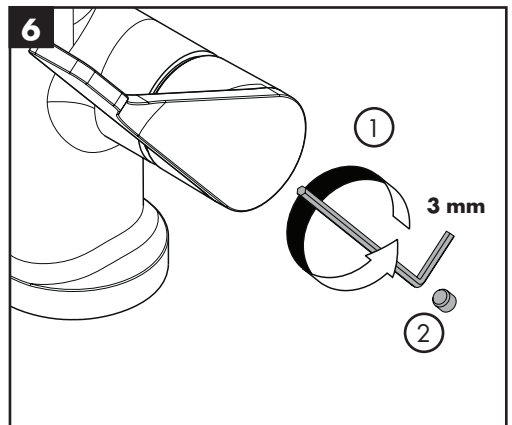
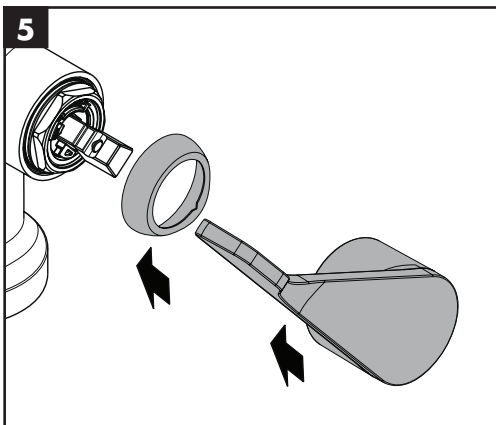
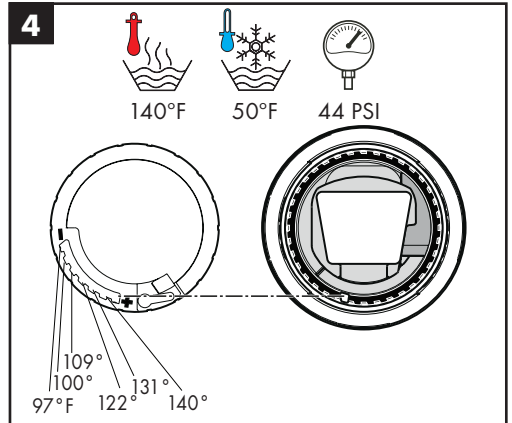
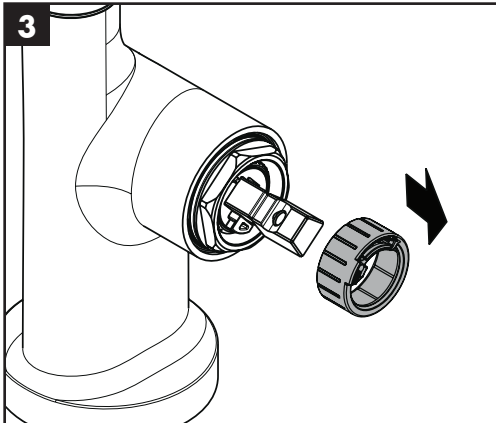
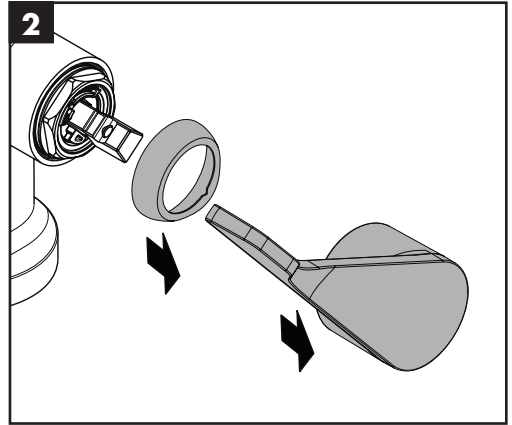
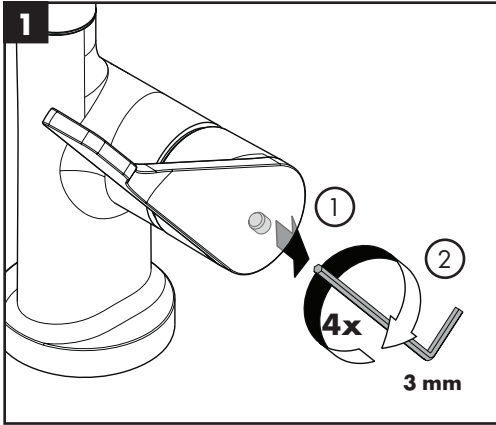

Replacement Parts / Pièces détachées / Repuestos

Montreux

16581xx1

16584xx1

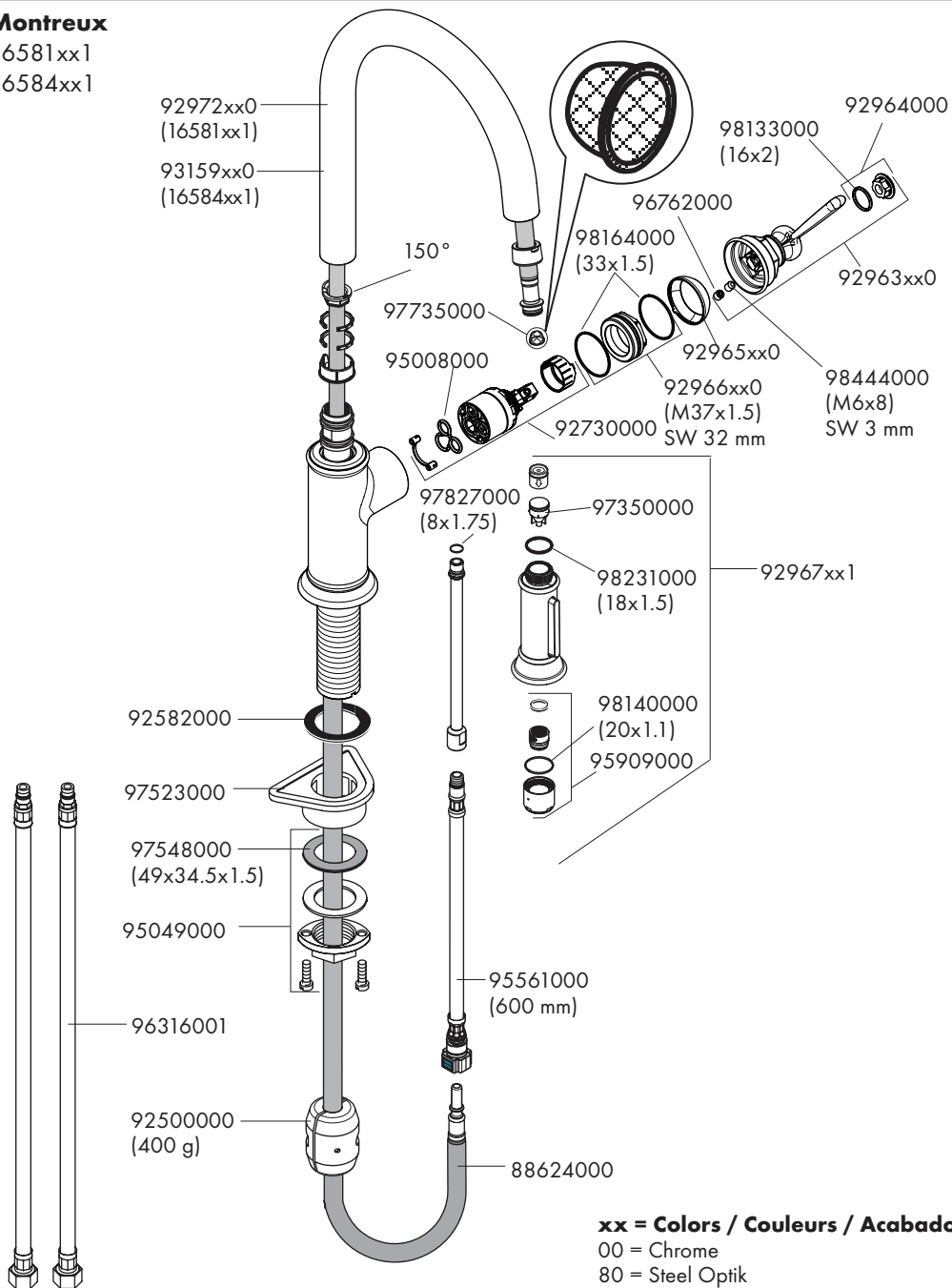

xx = Colors / Couleurs / Acabados

00 = Chrome

80 = Steel Optik

83 = Polished Nickel

User Instructions / Instructions de service / Manejo

on
ouvert
abierto

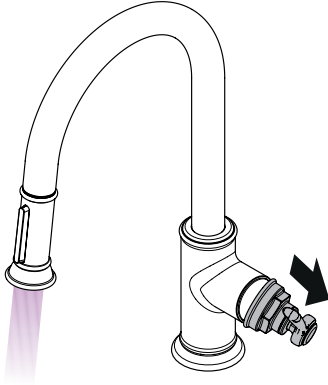

off
fermé
cerrar

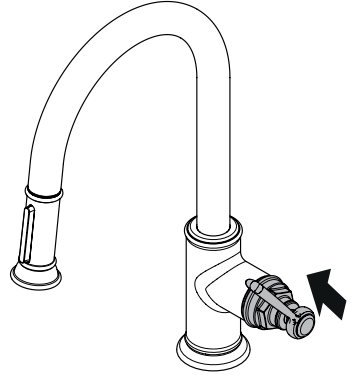

hot
chaud
caliente

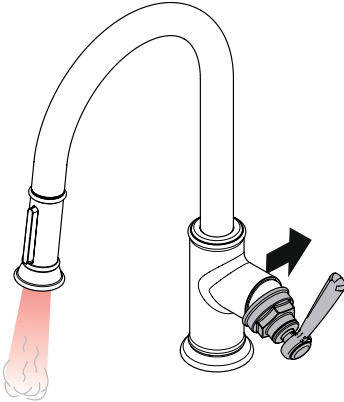

cold
froid
frío

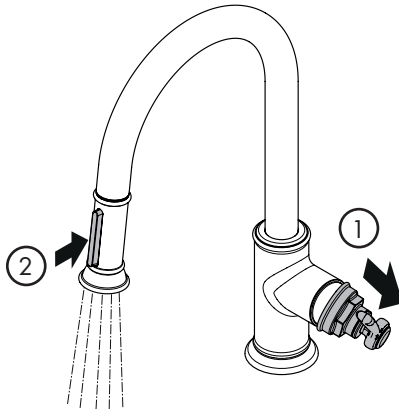
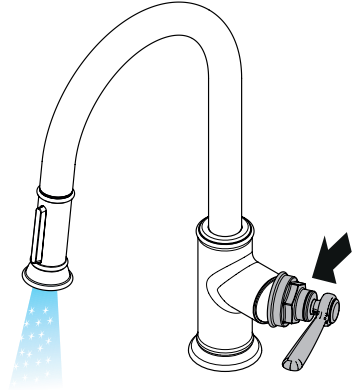

Cleaning / Nettoyage / Limpieza

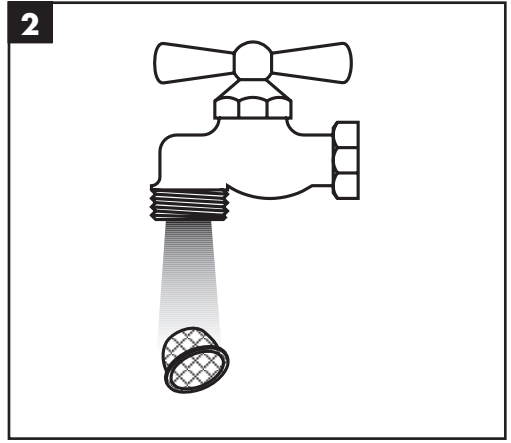
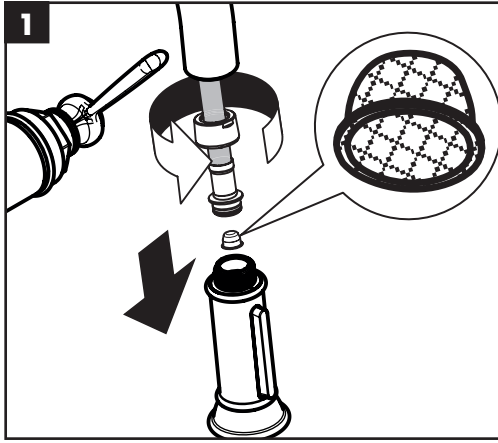

Maintenance / Entretien / Mantenimiento

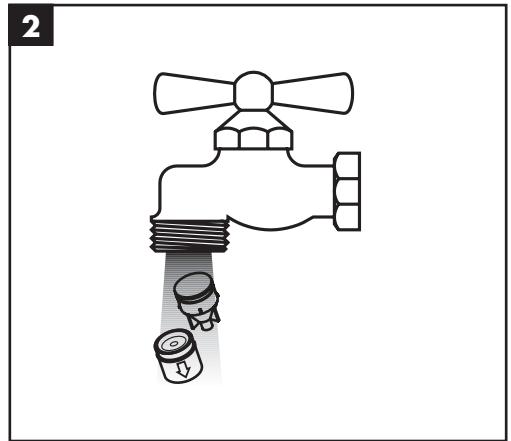
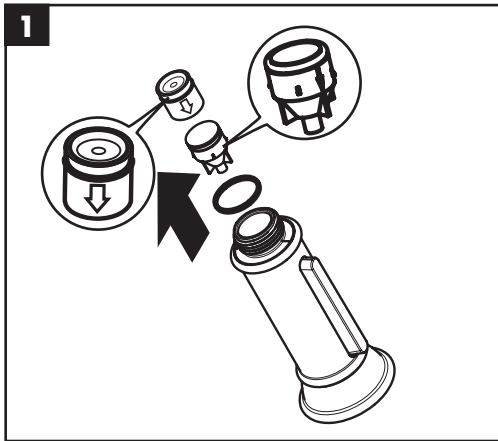

Cleaning Recommendation for Hansgrohe Products

Modern bathroom faucets, kitchen faucets and shower products are made from different materials to comply with the needs of the market with regard to design and functionality. To avoid damage to the product, it is necessary to take proper care of it.

For best results:

- Prevent the buildup of mineral scale and /or soap residue by cleaning your Hansgrohe product(s) when needed.
- Select a cleaning agent specifically intended for the type of product.
- **Do not** use these types of cleaners as they will cause damage to your Hansgrohe product:
 - ✗ Any cleaning agent containing hydrochloric acid, formic acid, lye, or acetic acid.
 - ✗ Abrasive cleaning powders, pads, or brushes.
 - ✗ Steam cleaners.
 - ✗ "No rinse" cleaning agents.
- **Always** follow the instructions provided by the manufacturer of the cleaning agent.
- **Do not** mix cleaning agents, unless directed by the manufacturer.
- **Do not** spray cleaners directly onto the product as drops could enter openings and gaps and cause damage. When using spray cleaners, spray the cleaner onto a soft cloth or sponge.
- **Always** rinse your Hansgrohe product thoroughly with clear water and polish dry with a soft cloth after cleaning.

Important

- Residue from soaps and shampoos can cause damage. Rinse the product with clean water after each use.
- Residue from basin/tub/tile cleaner can cause damage to faucets and fittings. Immediately rinse any overspray from the Hansgrohe product.
- **Damage to the product caused by improper care or the use of improper cleaning agents is not covered by the warranty.**
- **If a component of the product is damaged, replace it, as there is risk of injury.**

Conseil de nettoyage pour les produits Hansgrohe

Les robinets pour les salles de bains et les cuisines modernes ainsi que les produits récents pour les douches se composent de matériaux différents afin de satisfaire aux besoins du marché en termes de conception et de fonctionnalité. Afin d'éviter d'endommager le produit, il est nécessaire d'en prendre soin.

Pour de meilleurs résultats :

- Empêchez l'accumulation de tarte et/ou de résidu de savon en nettoyant votre produit Hansgrohe lorsque c'est nécessaire.
- Sélectionnez un produit de nettoyage spécifiquement prévu pour ce type de produit.
- **N'utilisez pas** ces types de nettoyants car ils peuvent endommager votre produit Hansgrohe :
 - ✗ Tout produit de nettoyage contenant de l'acide chlorhydrique, de l'acide formique, de la potasse ou de l'acide acétique.
 - ✗ Les poudres de nettoyage, les tampons ou les brosses abrasives.
 - ✗ Les nettoyeurs à vapeur.
 - ✗ Les produits de nettoyage « sans rinçage ».
- **Ne mélangez pas** les produits de nettoyage, à moins que cela soit indiqué par le fabricant.
- **Ne pulvérisez pas** les nettoyants directement sur le produit car des gouttes pourraient entrer dans les ouvertures et les fentes et causer des dommages. Lorsque vous utilisez des nettoyants par pulvérisation, pulvérisez le nettoyant sur un chiffon ou une éponge douce.
- Après le nettoyage rincer abondamment à l'eau claire pour éliminer intégralement les restes de détergent.

Important

- Les résidus de produits pour le corps comme les savons liquides, shampoings, gels de douche, teintures pour cheveux, parfums, après-rasage et vernis à ongles peuvent causer des détériorations. Rincez le produit avec de l'eau propre après chaque utilisation.
- Le résidu provenant des nettoyeurs pour cuvette/baignoire/carrelage peut endommager les robinets et les raccords de tuyauterie. Rincez immédiatement toute surpulvérisation sur le produit Hansgrohe.
- De même, il est interdit de stocker des détergents ou des produits chimiques sous les produits, par ex. dans un meuble sous lavabo, car les vapeurs qui s'en dégagent risquent d'abîmer les produits.
- **Les dommages au produit causés par un mauvais entretien ou par l'utilisation de produits de nettoyage inadéquats ne sont pas couverts par la garantie.**
- **Si un composant du produit est endommagé, remplacez-le, car il existe un risque de blessure.**

Recomendación de limpieza para los productos de Hansgrohe

Hoy en día, las griferías de baño y de cocina así como duchas modernas se componen de materiales muy distintos para satisfacer las exigencias del mercado respecto al diseño y la funcionalidad. Para evitar daños y reclamaciones hay que tener en cuenta ciertos aspectos tanto en el uso como en su limpieza.

Para obtener mejores resultados:

- Evite la acumulación de restos de jabón o sarro limpiando el producto Hansgrohe cuando sea necesario.
- Seleccione un agente de limpieza diseñado específicamente para el tipo de producto.
- **No use** estos tipos de limpiadores, ya que causarán daño a su producto Hansgrohe:
 - ✘ Agentes limpiadores que contengan ácido clorhídrico, fórmico, acético o lejía.
 - ✘ Polvos, paños o cepillos de limpieza abrasivos.
 - ✘ Limpiadores a vapor
 - ✘ Agentes de limpieza "sin enjuague".
- **Siempre** siga las instrucciones provistas por el fabricante del agente de limpieza.
- **No mezcle** los agentes de limpieza, a menos que esté indicado por el fabricante.
- **No rocíe** limpiadores directamente sobre el producto, ya que podrían caer gotas sobre las aberturas y espacios y causar daños. Cuando use limpiadores en spray, rocíe el limpiador sobre un paño suave o esponja.
- **Siempre** enjuague su producto Hansgrohe con agua limpia y séquelo y lustrelo con un paño suave después de la limpieza.

Importante

- Los residuos de productos de aseo como jabón líquido, champú, gel de ducha, tintes de pelo, perfumes, lociones de afeitado y esmalte de uñas pueden dañar también los materiales. Enjuague el producto con agua limpia después de cada uso.
- Los residuos de limpiadores para lavatorios, bañeras o azulejos pueden causar daño a los grifos y accesorios. Enjuague inmediatamente cualquier derrame que haya sobre el producto de Hansgrohe.
- Tampoco pueden generarse depósitos de productos de limpieza o químicos debajo de los productos, p. ej. En un armario de lavabo. De lo contrario, los vapores generados pueden dañar los productos.
- **Los daños que resulten de un cuidado inadecuado o uso de agentes de limpieza inadecuados no están cubiertos por la garantía.**
- **Si se daña un componente del producto, reemplácelo, ya que existe riesgo de lesión.**

Limited Consumer Warranty

This warranty is limited to products manufactured by Hansgrohe, Inc. ("Hansgrohe") that are purchased by a consumer in the United States or Canada after March 1, 1996, and installed in either the United States or in Canada.

WHO IS COVERED BY THE WARRANTY

This limited warranty extends to the original purchaser only. This warranty is non-transferable. Hansgrohe neither assumes nor authorizes any person to create for it any other obligation or liability in connection with this product.

LENGTH OF WARRANTY

If you are a consumer who purchased the product for use primarily for personal, family or household purposes, this limited warranty starts on the date of purchase and extends for as long as you own the product and the home in which the product is originally installed. If you purchased the product for use primarily for any other purpose, including, without limitation, a commercial purpose, this limited warranty starts on the date of purchase and extends (i) for 1 year, with respect to Hansgrohe and Commercial products, and (ii) for 5 years, with respect to Axor products. The Rubbed Bronze finish is subject to a 3-year limited warranty starting on the date of purchase.

WHAT IS COVERED BY THE WARRANTY

This limited warranty covers only your Hansgrohe manufactured product. Hansgrohe warrants this product against defects in material or workmanship as follows:

Hansgrohe will replace at no charge for parts only or, at its option, replace any product or part of the product that proves defective because of improper workmanship and/or material, under normal installation, use, service and maintenance. If Hansgrohe is unable to provide a replacement and repair is not practical or cannot be made in timely fashion, Hansgrohe may elect to refund the purchase price in exchange for the return of the product. REPAIR OR REPLACEMENT (OR, IN LIMITED CIRCUMSTANCES, REFUND OF THE PURCHASE PRICE) AS PROVIDED UNDER THIS LIMITED WARRANTY IS THE EXCLUSIVE REMEDY OF THE PURCHASER.

WHAT IS NOT COVERED BY THE WARRANTY

- A. Conditions, malfunctions or damage not resulting from defects in material or workmanship.
- B. Conditions, malfunctions or damage resulting from (1) normal wear and tear, improper installation, improper maintenance, misuse, abuse, negligence, accident or alteration; (2) the use of abrasive or caustic cleaning agents or "no-rinse" cleaning products, or the use of

the product in any manner contrary to the product instructions; or (3) conditions in the home such as excessive water pressure or corrosion.

- C. Labor and other expenses for disconnection, deinstallation, or return of the product for warranty service (including but not limited to proper packaging and shipping costs), or for installation or reinstallation of the product.
- D. Accessories, connected materials and products, or related products not manufactured by Hansgrohe.
- E. Any Hansgrohe or Axor product sold for display purposes.

HANSGROHE SHALL NOT BE LIABLE TO PURCHASER OR ANY OTHER PERSON FOR ANY INCIDENTAL, SPECIAL OR CONSEQUENTIAL DAMAGES, ARISING OUT OF BREACH OF THIS LIMITED WARRANTY.

Some provinces and some states do not allow the exclusion or limitation of incidental or consequential damages, so the above limitation or exclusion may not apply to you.

TO OBTAIN WARRANTY PARTS OR INFORMATION

Contact your Hansgrohe retailer, or contact Technical Service at:

Hansgrohe, Inc.
1492 Bluegrass Lakes Parkway
Alpharetta, GA 30004
Toll-free 800-334-0455

In requesting warranty service, you will need to provide:

1. The sales receipt or other evidence of the date and place of purchase.
2. A description of the problem.
3. Delivery of the product or the defective part, postage prepaid and carefully packed and insured, to:

Hansgrohe, Inc.
1492 Bluegrass Lakes Parkway
Alpharetta, GA 30004
Toll-free 800-334-0455

When warranty service is completed, any repaired or replacement product or part will be returned to you postage prepaid. REVISED MAY 1, 2016.

PRODUCT INSTRUCTIONS AND QUESTIONS

Upon purchase or prior to installation, please carefully inspect your Hansgrohe product for any damage or visible defect. Prior to installing, always carefully study the enclosed instructions on the proper installation and the care and maintenance of this product. If you have questions at any time about the use, installation or performance of your Hansgrohe product, or this warranty, please write us or call us toll-free at 800-334-0455.



hansgrohe

Hansgrohe, Inc. • 1490 Bluegrass Lakes Parkway • Alpharetta, GA 30004
Tel. 800-334-0455 • Fax 770-889-1783

www.hansgrohe-usa.com