

NOTES:

(N1) 1. FIT / FORM / FUNCTION SHALL FOLLOW PS-E.008.

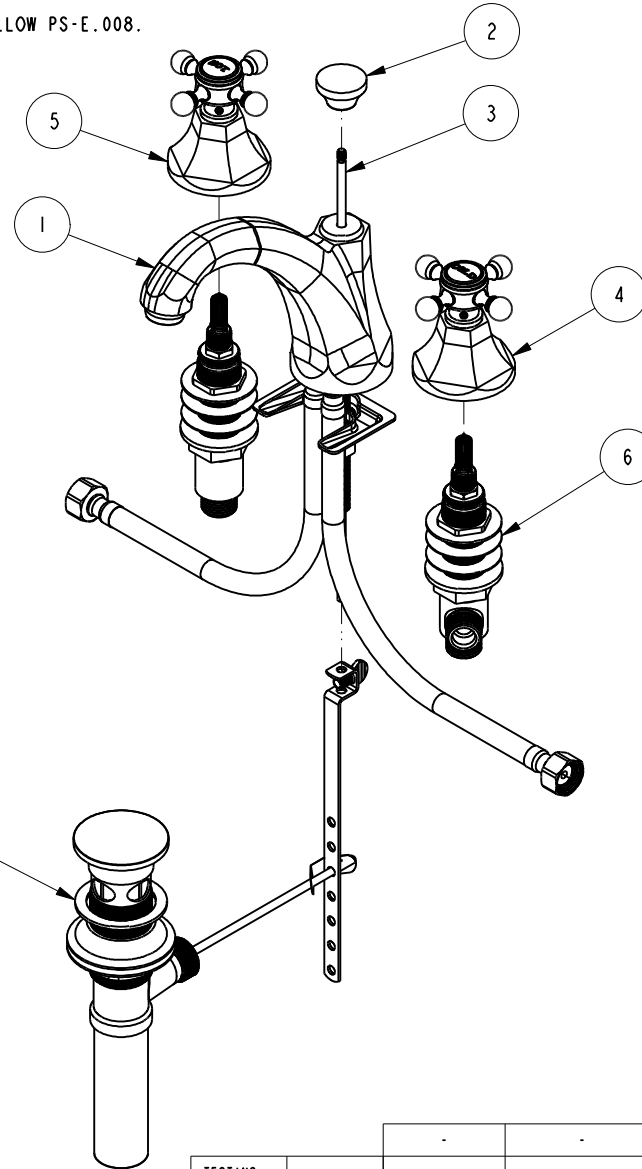

BILL OF MATERIAL (CURRENT LEVEL)

ITEM	PT/ASSY	DESCRIPTION	TYPE	QTY.
1	3-539	SPOUT ASM	ASSEMBLY	1
2	10961	SMOOTH POP - UP KNOB	PART	1
3	10288	3/16" POP UP ROD	PART	1
4	3-595C	HANDLE/ESC ASM, COLD	ASSEMBLY	1
5	3-595H	HANDLE/ESC ASM, HOT	ASSEMBLY	1
6	1-525	W/S VALVE ASM	ASSEMBLY	1
7	325	POP UP ASSEMBLY	ASSEMBLY	1

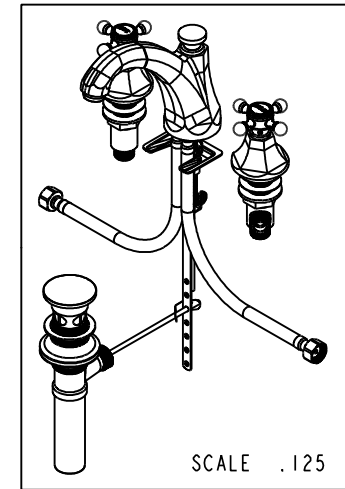

UNITS ARE: INCHES [MM]  
 TOLERANCES ARE:  
 FRACTIONS DECIMALS ANGLES  
 ±1/16" .X ±.1 [2.5] ±1°  
 .XX ±.06 [1.5]

(X.XXX) DENOTES CRITICAL DIMS.  
 ALL THREADS ARE CRITICAL

DRAWN VINAY 08/04/17  
 CHECKED RAVINDRA 08/04/17  
 APPROVED J.M 08/04/17

**BRASSTECH** 2001 CARNEGIE AVE.  
 INCORPORATED SANTA ANA, CA 92705  
 (949) 417-5207

WIDESPREAD FAUCET

DWG NO. 1220C REV A  
 SCALE .225 REF. - SHEET 1 OF 2

COPYRIGHT 2005 BRASSTECH, INC.  
 THESE DRAWINGS AND THE DESIGNS  
 DEPICTED HEREIN ARE THE PROPRIETARY  
 PROPERTY OF BRASSTECH. ANY USE  
 OR REPRODUCTION IS SUBJECT TO  
 THE EXPRESS APPROVAL OF BRASSTECH.  
 UNAUTHORIZED USE IS STRICTLY  
 PROHIBITED. ALL RIGHTS RESERVED.

TESTING	-	-	-
ASSEMBLY	-	-	-
PLATING	-	-	-
POLISHING	-	NEXT ASSY	USED ON
MACHINING	-	APPLICATION	
TOOLING FIXTURE #	REMOVE ALL BURRS AND SHARP EDGES		

ZONE	REV	DESCRIPTION	DATE	APPROVED
-	A	EN-3371	08/04/17	J.M
-	-	EN-3194	12/16/16	AN

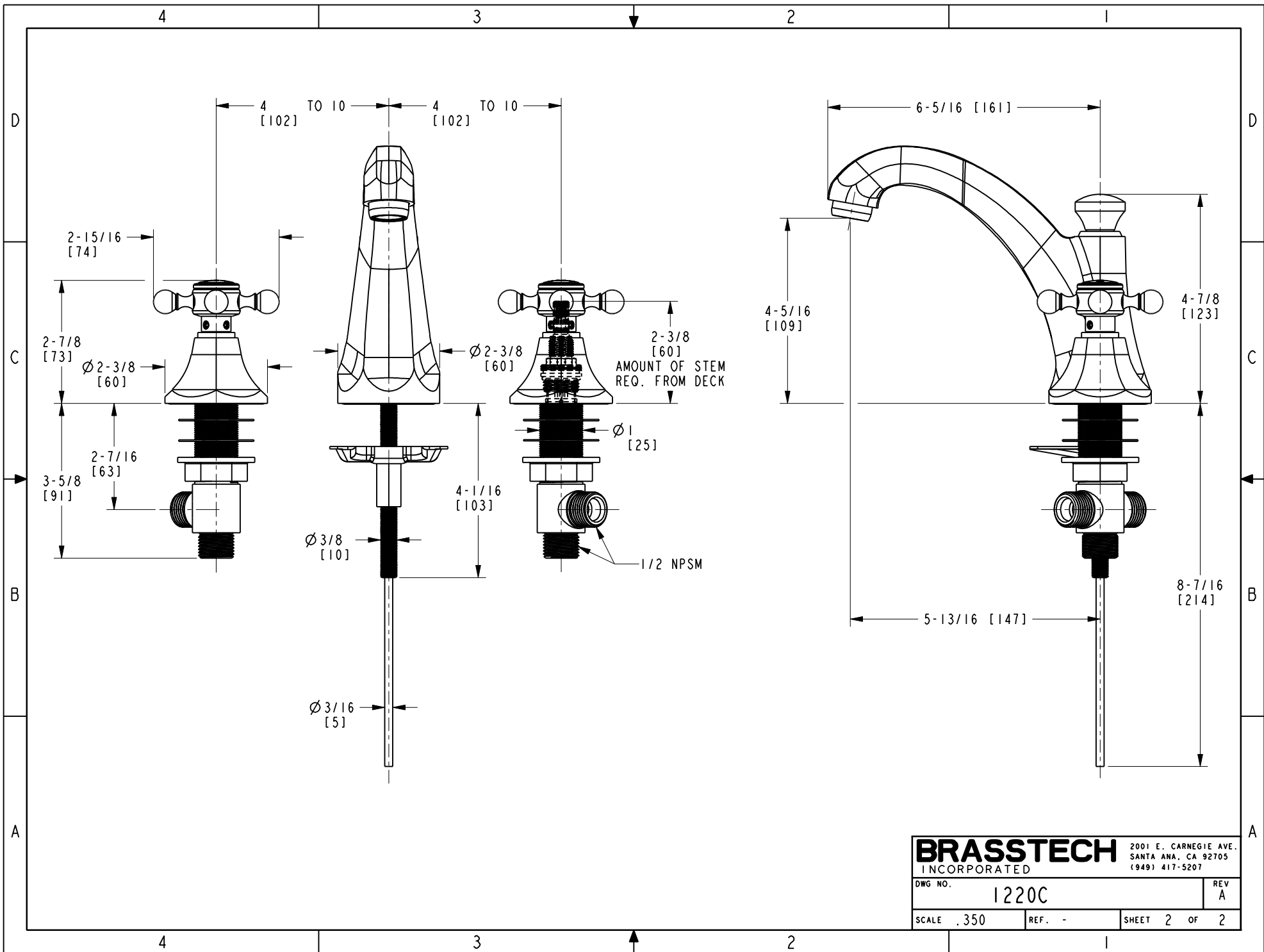

<b>BRASSTECH</b>		2001 E. CARNEGIE AVE. SANTA ANA, CA 92705 (949) 417-5207	
DWG NO.	1220C	REV	A
SCALE	.350	REF.	-
		SHEET	2 OF 2