

4

3

2

1

NOTES:

- (NI) 1. FIT / FORM / FUNCTION SHALL FOLLOW PS-E.008.
- 2. PACK THESE ITEMS IN A PLASTIC BAG.
- 3. HANDLE IN CLOSE POSITION.
- 4. APPLY LOCTITE 680 ONLY AFTER ADJUSTING HANDLES IN THEIR OPTIMAL POSITION.
- 5. INSTALLATION TORQUE 11-14 LB-FT.
- 6. APPLY LOCTITE 242.
- 7. INSTALLATION TORQUE 6-9 LB-FT.
- 8. APPLY LOCTITE 680.
- 9. ADJUST THIS ITEM TO OPTIMIZE HANDLE POSITION

BILL OF MATERIAL (CURRENT LEVEL)

ITEM	PT/ASSY	DESCRIPTION	TYPE	QTY.
1	11299	VALVE BODY, WALL-END	PART	1
2	1-326	W/S CARTRIDGE FRICTION - HOT	PART	1
3	12095	BONNET	PART	1
4	11301	FLANGE, MOUNTING	PART	1
5	2-555	FLANGE ASM, TRAD	ASSEMBLY	1
6	92231	SCRW, 1/4-20 X 1/4 SKT HD CUP PT SS	PART	1
7	92223	SCRW, #8 X 2-1/2 PHL FLT HD SS	PART	4
8	2-550	LOWER ARM ASM, TRAD	ASSEMBLY	1
9	2-549	UPPER ARM ASM, TRAD	ASSEMBLY	1
10	91325	WSHR, .23 ID X .625 OD X .093 THK, FLT, NEOPRENE	PART	1
11	1-134	CARTR 3/8 HOT 1/4 TR	PART	1
12	11835	ADAPTER	PART	1
13	12747	BODY HANDLE	PART	2
14	92192	SCRW, 10-32 X 5/8 SKT HD CUP PT SS	PART	2
15	11834	ADAPTER	PART	1
16	92477	SCRW, M4 X 16 SKT FLT HD SS	PART	1
17	92487	SCRW, M4 X 30 SKT FLT HD CAP ALOY STL	PART	1
18	12583	LEVER HANDLE	PART	2

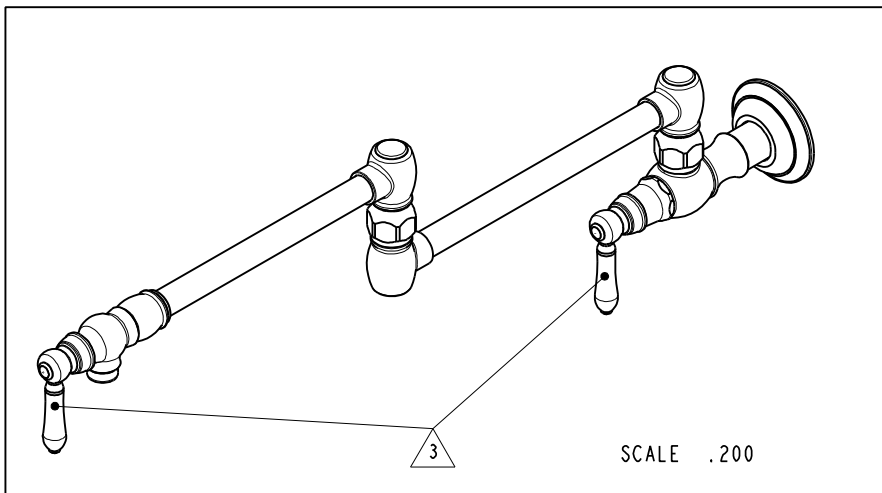

TESTING	-	-	-
ASSEMBLY	-	-	-
PLATING	-	-	-
POLISHING	-	NEXT ASSY	USED ON
MACHINING	-	APPLICATION	
TOOLING	FIXTURE #	REMOVE ALL BURRS AND SHARP EDGES	

UNITS ARE: INCHES [MM]
 TOLERANCES ARE:
 FRACTIONS DECIMALS ANGLES
 $\pm 1/16"$.X $\pm .1$ [2.5] $\pm 1"$
 $\pm .001$.XX $\pm .06$ [1.5]
 (X.XXX) DENOTES CRITICAL DIMS.
 ALL THREADS ARE CRITICAL
 DRAWN JINSON 03/26/18
 CHECKED J.A. 03/26/18
 APPROVED J.A. 03/26/18

BRASSTECH 2001 CARNEGIE AVE.
 INCORPORATED SANTA ANA, CA 92705
 (949) 417-5207

WALL MOUNT POT FILLER - CHESTERFIELD

DWG NO. 1030-5503 REV B

SCALE .250 REF. - SHEET 1 OF 3

-	B	EN-3495	03/26/18	J.A.	COPYRIGHT 2005 BRASSTECH, INC. THESE DRAWINGS AND THE DESIGNS DEPICTED HEREIN ARE THE PROPRIETARY PROPERTY OF BRASSTECH. ANY USE OR REPRODUCTION IS SUBJECT TO THE EXPRESS APPROVAL OF BRASSTECH. UNAUTHORIZED USE IS STRICTLY PROHIBITED. ALL RIGHTS RESERVED.
-	A	EN-3272	05/18/17	N.S	
-	-	EN-2980i	10/6/16	J.A.	
ZONE	REV	DESCRIPTION	DATE	APPROVED	

4

3

2

1

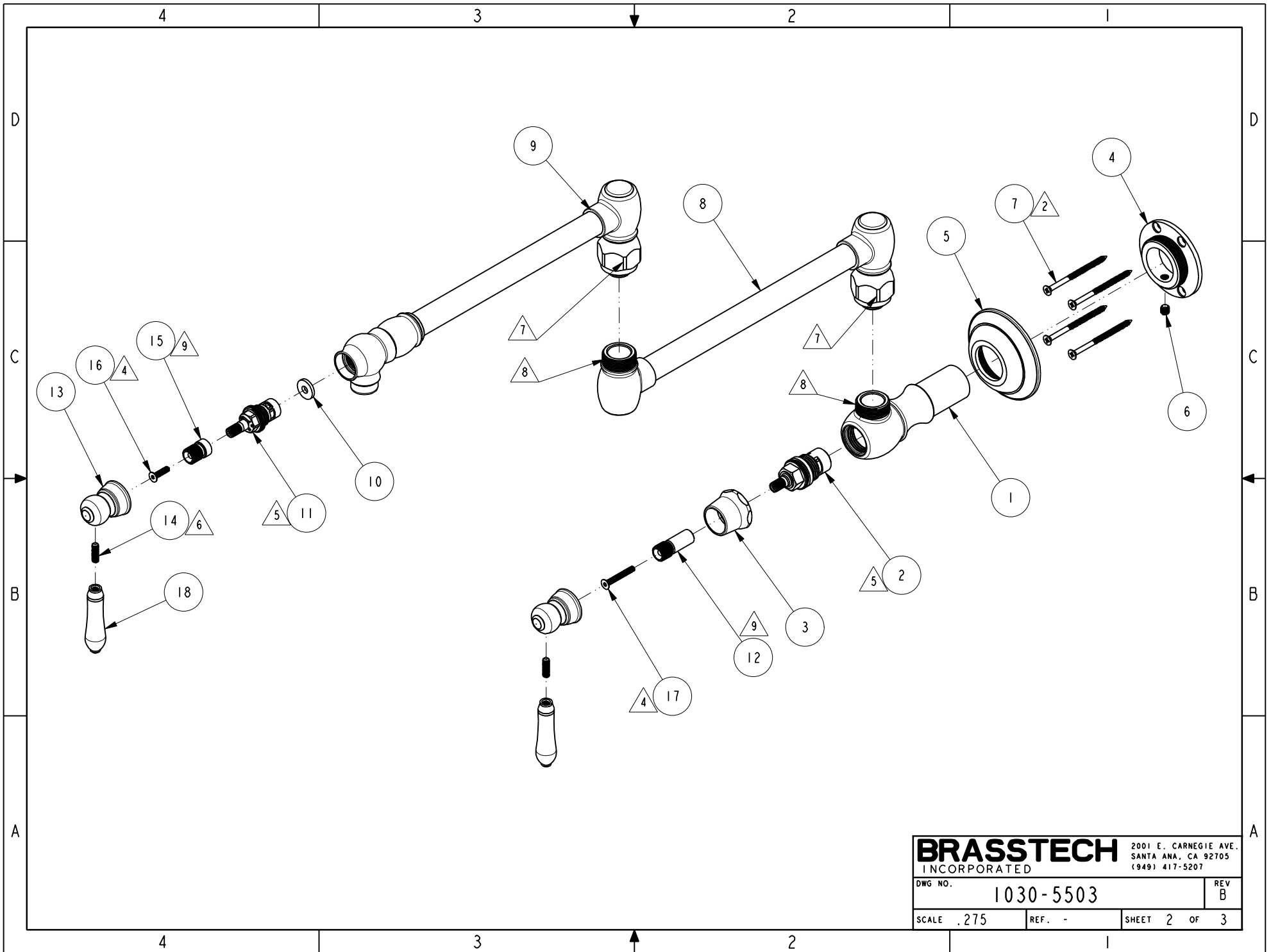

BRASSTECH INCORPORATED		2001 E. CARNEGIE AVE. SANTA ANA, CA 92705 (949) 417-5207
DWG NO.	1030-5503	REV B
SCALE .275	REF. -	SHEET 2 OF 3

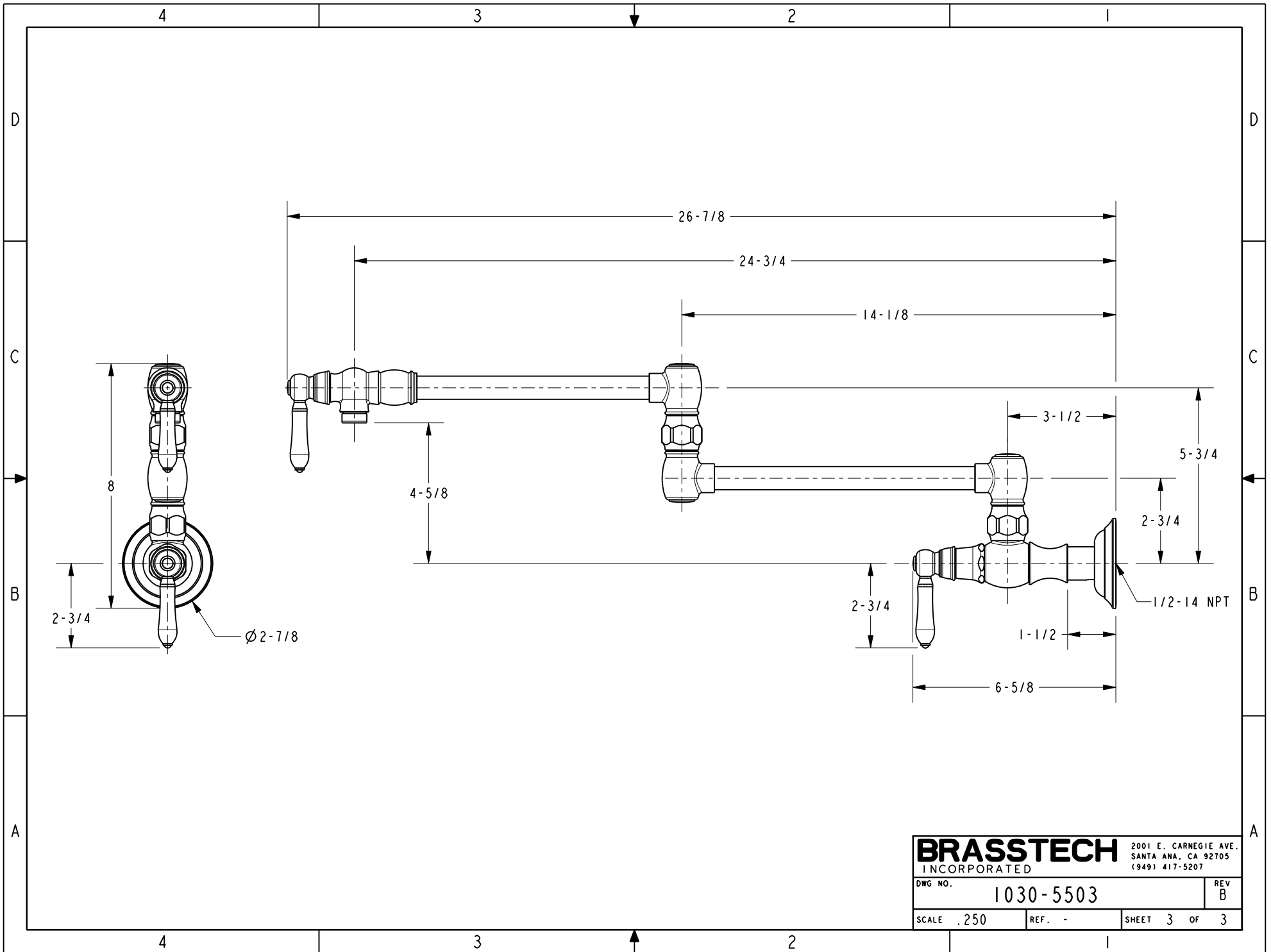

BRASSTECH 2001 E. CARNEGIE AVE.
 INCORPORATED SANTA ANA, CA 92705
 (949) 417-5207

DWG NO.	1030-5503	REV	B
SCALE	.250	REF.	-
SHEET 3		OF 3	